

JOURNEYMAN FARMER CERTIFICATE PROGRAM

Small Fruit and Vegetable Production Facilitator Notebook



Supported
by:



Beginning Farmer Rancher Development Program

Developing the Next Generation of Sustainable Farmers in Georgia
In partnership with:





Beginning Farmer and Rancher Development Program:

Developing the Next Generation of Sustainable
Farmers in Georgia Grant



This material is based upon work that is supported by the National Institute of Food and Agriculture, U.S. Department of Agriculture, under award number 2015-70017-22861.

Facilitator Notebook

Table of Contents

General Agenda.....	1
Learning Objectives.....	2
 Session 1	
Session 1: Notes to Facilitators.....	4
Interpreting Soil Tests Worksheet.....	6
Soil Test Report.....	9
The Foundation A Systems Approach Power Point Slides.....	10
Soil Health & Fertility Power Point Slides.....	14
Case Studies.....	28
Session 1: Resource Page.....	35
 Session 2	
Session 2: Notes to Facilitators.....	38
Soil Test and Fertilizer Application Worksheet Key.....	40
Cover Crop Jeopardy Notes to Facilitators.....	42
Soil Fertilizers and Amendments Power Point.....	43
Cover Crops Power Point Slides.....	51
Cover Crop Jeopardy Power Point Slides.....	62
Ground Covers for Small Fruits.....	71
How to Convert and Inorganic Fertilizer Recommendation to an Organic One.....	74
Session 2: Resource Page.....	84
 Session 3	
Session 3: Notes to Facilitators.....	87

Applying Pest Management Strategy Worksheet Key.....	89
Featured Creatures Handout.....	93
Table 2-29.....	98
Table 2-25.....	100
Summer Squash: Pages 85-87.....	101
Crop Rotation Power Point Slides.....	104
Pest Management Slides.....	110
Pesticide Safety Power Point Slides.....	116
Session 3: Resource Page.....	119
Session 4	
Session 4: Notes to Facilitators.....	122
Locally Yours Farm Transplant Worksheet Key.....	123
Seasonality Power Point Slides.....	125
Crop Selection Power Point Slides.....	129
Vegetable Propagation, Seeds, and Transplants.....	137
Considerations for Small Fruit Production.....	145
Session 4: Resource Page.....	149
Session 5	
Session 5: Notes to Facilitators.....	152
Case Study Discussion Power Point Slides.....	156
Double Digging Diagram.....	162
Equipment and Tools for Small-Scale Intensive Crop Production Handout.....	163
Tractor Primer for the Market Farm Handout.....	179
Drip Irrigation Systems Handout.....	190
Session 5: Resource Page.....	214

Session 6

Session 6: Notes to Facilitators.....217

Postharvest Management of Vegetables Power Point Slides.....220

Postharvest Learning Activity Power Point Slides.....229

CoolBot Power Point Slides.....232

Food Safety Power Point Slides.....245

Water Use Handout.....252

Farmer Worker Toilet and Handwashing Facilities.....254

Farm Self-Help Form.....256

Food Safety Rules under FSMA Handouts.....258

Example Field Map.....263

Example Crop Characteristics Work Table.....264

Example Field Futures Work Table.....265

Session 6: Resource Page.....266

Session 7

Session 7: Notes to Facilitators.....269

Marketing Power Point Slides.....271

Crop Plans Power Point Slides.....284

Session 7: Resource Page.....291

Small Fruit and Vegetable Production General Agenda

Session One:

- The Foundation
- Soil Health and Fertility

Session Two:

- Soil Fertilizers & Amendments
- Cover Crops
- Groundcovers for Small Fruits

Session Three:

- Crop Rotation
- Pest Management
- Pesticide Safety

Session Four:

- Seasonality
- Crop Selection
- Vegetable Propagation, Seeds and Transplants
- Considerations for Small Fruit Production

Session Five:

- Irrigation, Equipment and Tillage

Session Six:

- Post-Harvest Handling
- Food Safety

Session Seven:

- Marketing
- Crop Plans

Small Fruit and Vegetable Production

Learning Objectives

- List the components of soil
- List three examples of how organic matter affects the physical, chemical, and biological properties of a soil.
- Interpret a sample soil test report
- Calculate how much N, P₂O₅, K₂O is in 10-10-10
- Give examples of fertilizers
- Recognize the characteristics of a well stabilized compost
- List three reasons you might want to use cover crops
- Name three major plant families used for cover crops
- Identify groundcovers that are beneficial for reducing weeds in small fruit production
- Recognize characteristics of a good crop rotation program
- Name the five-part strategy of sustainable pest management
- List three sustainable weed management practices
- List three sustainable insect management practices
- List three sustainable disease management practices
- Recognize if a particular crop is a warm or cool season
- Give an example of a crop that should be direct seeded
- List three reasons you might want to use a transplant
- Name three resources for small fruit production
- List three reasons to have an irrigation system for your crops
- Recognize how tillage effects the physical, chemical and biological properties of the soil
- Give an example of an appropriate planter for a 1 to 2-acre farm
- Identify five factors that can affect shelf-life
- List the six areas of concern for food safety on the farm
- List three major differences between wholesale and direct sales markets
- Learn alternative methods of crop scheduling
- Learn importance of matching crop production with market



Small Fruit and Vegetable Production

A Systems Approach;
Soil Health and Fertility

Session One
Facilitator Notebook

Session 1 – The Foundation; Soil Health and Fertility Facilitator Agenda

The Foundation

Introductions (15 minutes)

Before you begin the webinar, go around the room and ask the class to briefly introduce themselves using:

- their name
- the county where they live
- three words to describe themselves

A Systems Approach (10 min-Julia Gaskin, Crop & Soil Dept., University of Georgia)

- Farm as a system; interrelationships of soils, plants, animals, and humans
- Case studies

Homework Assignment – Read the case studies before you come back next week. These are in the notebooks after Session 1 material. Remind the class that these are not real farms but idealized farms to illustrate different approaches at different locations and scales.

Soil Health and Fertility

Soil Health and Fertility (40 min-Julia Gaskin, Crop & Soil Dept., University of Georgia)

- Soil physical, chemical and biological components
- Soil organic matter and how it affects soil chemistry, physical properties and biology
- pH, macro and micronutrients and their role in plant growth
- Soil sampling and interpreting routine soil test results

Learning Objectives:

- List the components of soil
- List three examples of how organic matter affects the physical, chemical, and biological properties of a soil
- Interpret a sample soil test report

At SLIDE 16 –Pause presentation for Activity

Learning Activity (15 min)-Soil Organic Matter

For this exercise, you will need to collect 4 soil samples from your area: forest, well-managed pasture, conventionally tilled agricultural land, and land that has been in either conservation tillage with cover crops or organic production for at least 5 years. Try to find soils with similar textures. For example, if most of the soils in your area are sandy loams, then try to find a sandy loam soil from each of the land uses. Please don't

pick a clayey soil for one land use to contrast with a sandy soil in another. Clayey soils usually naturally contain more soil organic matter.

The samples should be 8 to 10 inches deep and should show the transition between the surface soils layer (A horizon) and the first subsurface horizon (most likely a B horizon but possibly an E). For best results, place these samples in a small plastic container with the soil layers exposed to the surface. Try to keep the A horizon intact with plant roots and any plant residue or the forest floor on the surface.

The samples should represent the amount of soil organic matter that can naturally form in your area. Samples from a local forest that has not been logged for 40 to 50 years or longer are the best example of this. A well-managed pasture soil will also show the participants the capacity soils in your area have for accumulating soil organic matter naturally. Conventionally tilled agricultural land is usually the lowest in soil organic matter. Agricultural land that has been in either conservation tillage with cover crops or organic production for 4 to 5 years should have a good soil organic matter for your area.

Before your session, wet the soil samples lightly. Please don't saturate them, but these should be moist.

Have the class look at the soils from different land uses. Arrange the soil samples by darkest brown A horizon to lightest. Discuss how color indicates the amount of soil organic matter. Point out soil pores and roots. Remind the class about the importance of soil pores in supplying air and water to plants. Use a knife to tease out roots from each soil. Point out how small soil aggregates cling to roots. Use the exercise to illustrate what good soil tilth and a healthy soil is in your area. If you have enough of a sample, encourage the class to pick up a small portion of each soil and feel it.

NOTE: You may want to ask a local NRCS field person to help with this.

RESTART the Presentation

AT SLIDE 28 – Pause presentation for Activity Learning Activity (30 min)-Interpreting Soil Tests

Discuss the questions on the following page with participants.

RESTART the Presentation to finish.

Interpreting Soil Tests (Answers for facilitators are in italics)

1. The very small farm-Locally Yours- does not soil test but adds certain amendments every year. What are the risks with this?

Could be adding unnecessary amendments and wasting money. Could also be creating nutrient imbalances. Phosphorus is a good example since it builds up if organic fertilizers are used.

2. If Locally Yours Farm adds lime every year without soil testing, what could happen to soil pH? What does that do to the availability of phosphorus? Micronutrients like zinc?

Adding lime raises the pH, or makes the soil less acidic. As pH raises above 6, the availability of phosphorus decreases. Zn, B, Mg also decrease in availability as pH raises.

3. What are the consequences of phosphorus build up and its effect on water quality?

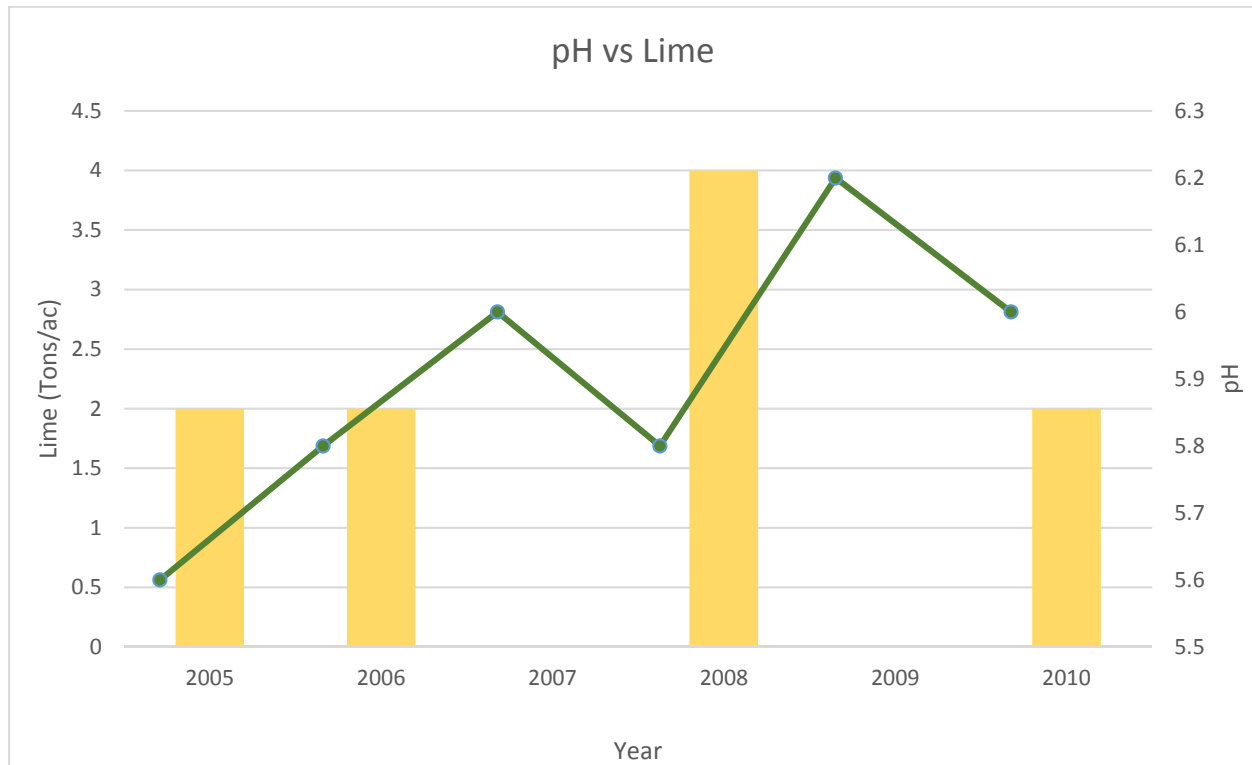
Phosphorus can have detrimental effects on water quality at low concentrations. Excess Phosphorus in water can lead to eutrophication and fish deaths.

4. What can happen to profitability if you are using inputs you don't need for good crop growth?

This is expensive and causes you to waste resources.

5. Look at the graph on pH from Wanna B Farms. Discuss the graph. How is the soil responding to lime addition and when is lime needed?

Try to get them to tell you: how the soil is responding to lime addition and when lime is needed.



*Explain soil pH is on the right axis and the amount of lime applied on the left axis. Note the line shows pH response and bars show amount of lime added. The initial soil pH was 5.6. Although the soil test recommendation called for 4 tons/acre of lime, the farm didn't have much money so they just applied 2 tons/acre in the early winter of 2005. The soil pH rose to 5.8, which is better but not at the target of 6.0 to 6.5. The farm added another 2 tons/ac in the early winter of 2006 to bring the pH up to the target range. In 2007, the soil pH was in the target range because it reached 6.0 and the farmers decided not to add lime. The winter of 2007 was a wet year and grew heavy feeding crops in the field, by the fall of 2008, the soil pH had fallen to 5.8 again. The farmers decided to apply 4 tons/acre of lime. This brought the soil pH well up into the target range, so again no lime was applied in 2009. In 2010, the farmers applied 2 tons/acre to keep the pH in the target range. **Note—this is an example and soils at your farm may not respond like this***

6. Refer to the soil test from Gittin' There Farms on the next page.
- a. Is the pH in the target range?
Yes.
 - b. Why is no limestone recommended?
Because pH levels are adequate
 - c. Does the Soil Test Index for phosphorus represent total or plant available phosphorus? Why might you add 20 lbs P/ac as fertilizer with plant available fertilizer in the very high range?
According to results, very high levels of soil test phosphorus in soil. This is an index of available Phosphorus. A small amount of P₂O₅ is often used to get seeds or transplants off to a good start.
Note: For organic fertilizers, Phosphorus may be present in soil, but may not be in plant available forms.
 - d. Does the soil need potassium?
Yes. Many crops need almost as much potassium as nitrogen.
 - e. Look at nitrogen fertilizer recommendations. Why might you want to split when fertilizer is applied?
Point out there aren't nitrogen results. There aren't nitrogen results because Nitrogen is quickly lost from the soil and measurements of plant available Nitrogen are not accurate for a growing season. Nitrogen fertilizer recommendations are based on years of fertilizer trial results. Sometimes farmers apply nitrogen in split applications for certain crops (such as corn). By splitting the nitrogen application, you can supply nitrogen when the crop needs it most, maximize uptake and reduce loss of nitrogen.
 - f. If soil organic matter is 2%, is this good for a sandy soil in Georgia?
Yes.

Soil Test Report

Sample ID

Client Information

Gittin' There Farms

Sample: 1

Crop: Kale, fresh market

(CEC/CEA Signature)

Lab Information

Lab #2889

Completed: Aug 4, 2010

Printed: Jul 16, 2015

Tests: S1

Contact

Soil, Plant, and Water Laboratory

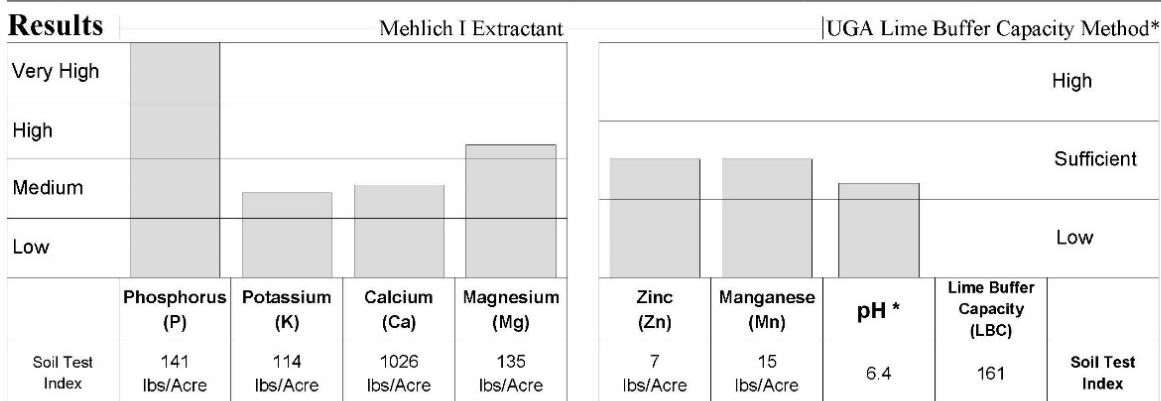
2400 College Station Road

Athens, GA 30602

ph: 706-542-5350

e-mail: soiltest@uga.edu

Results



Recommendations

Can't find a specific grade of fertilizer? Try our Fertilizer Calculator: <http://aesi.ces.uga.edu/soil/fertcal/>

Limestone	Nitrogen (N)	Phosphate (P ₂ O ₅)	Potash (K ₂ O)	Sulfur (S)	Boron (B)	Manganese (Mn)	Zinc (Zn)
0 tons/Acre	175-225 lbs/Acre	20 lbs/Acre	150 lbs/Acre	10 lbs/Acre	2 lb/Acre	—	—

Recommended pH: 6.3 to 6.8

*For information on how the Soil, Plant, and Water Laboratory measures and reports pH and makes lime recommendations, see <http://aesi.ces.uga.edu/soil/SoilpH.html>.

Nitrogen (N) rates will vary depending on rainfall, soil type, irrigation, plant population and method and timing of applications.

For transplants, apply a starter solution using 3 pounds of 10-34-0 per 50 gallons of water.

For early growth stimulation apply a pop-up fertilizer using 100 to 150 pounds of 10-34-0 or similar material per acre. Apply the fertilizer 2 to 3 inches to the side of the seeds or plants and 2 to 3 inches below the seeds or roots.

Sulfate of potash magnesia may be used to supply a portion of the recommended potash (K₂O) and to also supply magnesium (Mg) and sulfur (S).

For more efficient use of fertilizer split the applications, applying one-third to one-half down (banded or incorporated in the bed) and the remainder in 1 to 3 applications. If the fertilizer is broadcast, increase the application rates of phosphate (P₂O₅) and potash (K₂O) 1½ to 2 times.

NOTE: The amount of nitrogen (N), phosphate (P₂O₅), and potash (K₂O) actually applied may deviate 10 pounds per acre from that recommended without appreciably affecting yields.

Learning for Life

The University of Georgia and Fort Valley State University, the U.S. Department of Agriculture and counties of the state cooperating. Cooperative Extension offers educational programs, assistance and materials to all people without regard to race, color, national origin, age, gender or disability. An equal opportunity/affirmative action organization committed to a diverse work force.



Small Fruit and Vegetable Production



Session 1 The Foundation – A Systems Approach

Julia Gaskin
Sustainable Agriculture Coordinator
Crop & Soil Science Dept
University of Georgia



Photo: Julia Gaskin



How Do We Farm More Sustainably?

- Think about a systems approach
 - i.e. everything is related to everything else
- Work with natural cycles to reduce inputs
 - Build soil health
 - Biodiversity
 - Ecologically based pest management

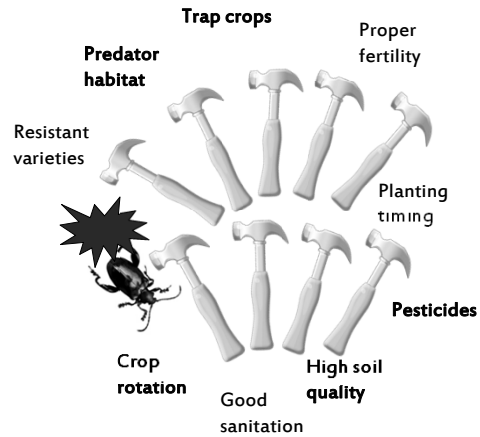


Photos: Julia Gaskin



Sustainable Approach Many Little Hammers

Reaction Farming



Many Little Hammers

Example – plant parasitic nematodes

- Organic amendments
 - improves soil tilth, water holding capacity, etc. so reduces plant stress
- Use cover crops in mustard family
 - Glucosinolates reduce nematode population
- Release predatory nematodes
 - Biocontrol
- Rotate into crops that aren't hosts



Mustard cover crop
Photo from Extension.org

Irrigation, Weeds, Plant Disease, and Food Safety



Limited water in middles reduces weed growth



Raindrop hitting the soil at 15 mph



Drip irrigation prevents soil splash



Reduces plant disease



E. coli O157:H7 on the cut edge of a lettuce leaf
Courtesy of Dr. Joseph Frank, University of Georgia Dept. of Food Science and Technology

Reduce potential pathogens

What Is Your System?

Time



Soils



Landscape

Equipment



Crops



Fertility

Primary Pests

Photos:
Julia Gaskin

Case Studies

- Very small (< 1 acre) - Locally Yours Farm
- Small (2 acres) – Wanna B Farms
- Mid-scale (14 acres) – Gittin' There Farms



JOURNEYMAN FARMER
CERTIFICATE PROGRAM

JOURNEYMAN FARMER CERTIFICATE PROGRAM

This material is based upon work that is supported by the National Institute of Food and Agriculture, U.S. Department of Agriculture, under award number 2015-70017-22861.

 **USDA** Beginning Farmer and Rancher
 **NIFA** Development Program
Developing the Next Generation
of Sustainable Farmers in Georgia Grant





Small Fruit and Vegetable Production



Session 1 Soil Health & Fertility

Julia Gaskin
Sustainable Agriculture Coordinator
Crop & Soil Science Dept
University of Georgia

Learning Objectives

- List the components of soil (mineral, soil organic matter, air, and water).
- Interpret a sample soil test report.
- List three examples of how organic matter affects the physical, chemical, and biological properties of a soil.

What is Soil?



Photo: Julia Gaskin

Composed of:

- sand, silt, clay,
- organic matter (don't forget the critters),
- water, and
- air

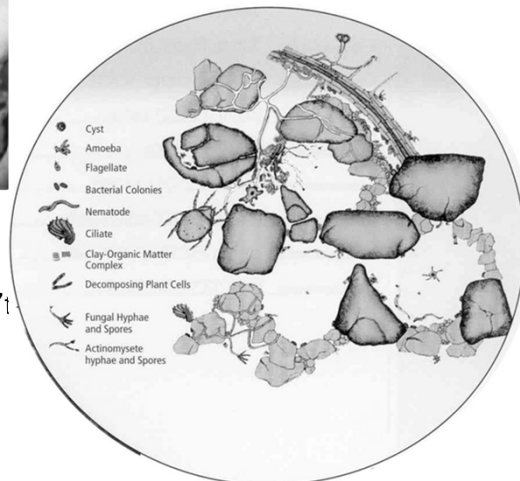
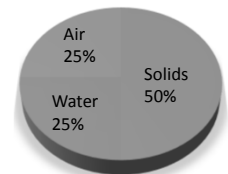


Illustration from Soil Biology Primer, USDA NRCS

Ideal Soil



Goal is Healthy Soil

- Good tillth
- Nutrients for healthy plants and good yields
- Good water storage and drainage
- Low disease and pest pressure
- Able to bounce back from disturbance



Photo: Julia Gaskin

Key Factors for Healthy Soils

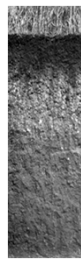
- Soil organic matter
- pH
- Management effects on soil tillth



Photo: Julia Gaskin

Fertility and Georgia Soils

- Hot, humid climate
- History of poor soil management
- High soil erosion
- Low soil organic matter



Photos: NICS

Georgia soil vs Midwest prairie soil

Soil Organic Matter

- Texture* you've got!
- Soil organic matter you **can** improve.



0.5% soil organic matter

2.5% soil organic matter

*Texture is determined by percent sand, silt, and clay in a soil e.g. loam, loamy sand, sandy clay loam. See resource materials.

The difference soil organic matter can make!

Soil Organic Matter

“The living, the dead, and the very dead.”

Dr. Fred Magdoff

The living

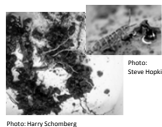


Photo: Henry Schomburg

The dead



Photo: Jimmy Dean

The very dead



Photo: http://www.davistartling.info/encyclopedia/01/01_01humus.html

Primarily composed of carbon

Soil Organic Matter – Effects Soil Properties

- *Chemical*
 - Source of nutrients
 - Helps hold nutrients in the soil
- *Physical*
 - Helps create and maintain soil structure
- *Biological*
 - Base of food chain

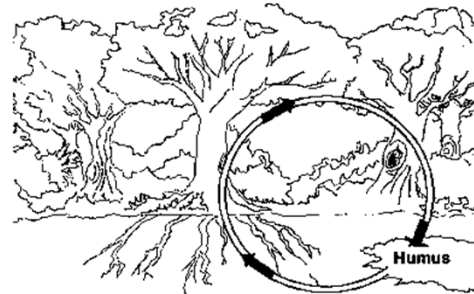


Photo: Julia Gaskin

Soil Organic Matter – Your Nutrient Bank

Chemical

- Each 1% soil organic matter releases about 10 lbs nitrogen
- Also source of:
 - Potassium
 - Some phosphorus
 - Sulfur
 - Micronutrients – copper, iron, zinc



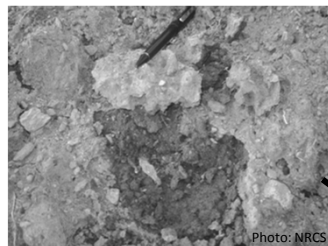
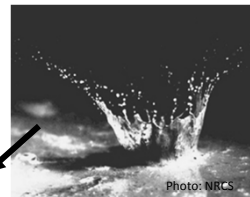
Drawing from fao.org

Soil Organic Matter & Soil Structure

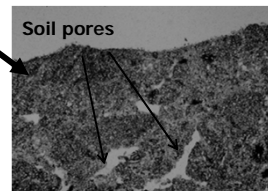
Physical

- Good soil structure keeps pores open for water and air
- Clay and organic matter are important

Raindrop hits the soil at 15 miles per hour.



Dislodged soil particles form crusts



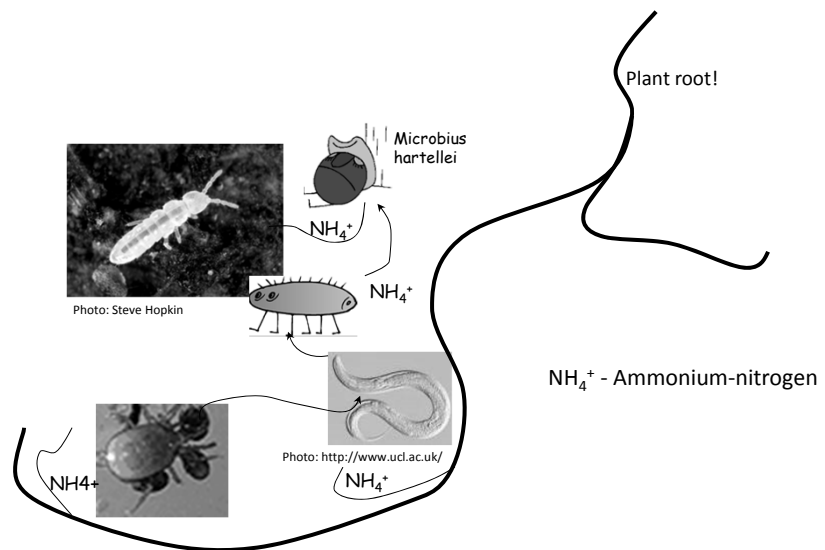
Plugged pores decrease water and oxygen exchange

Photo: Bill Miller

Soil Organic Matter & Life

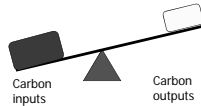
Biological

- Energy source for microbial life.
- Base of the food chain.
- Release nutrients-mineralization



How Do We Maintain and Build Soil Organic Matter?

Balance – Add more than you lose



- Reducing tillage
- Cover crops
- Organic amendments (manures, composts, etc)

Soil Organic Matter – Case Studies

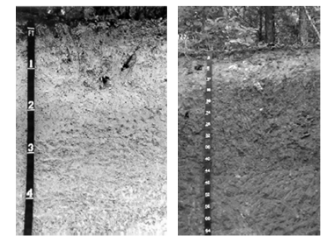
- Very small farm – Locally Yours Farm
 - Biointensive – always something growing
 - Roots, compost and manures add organic matter
 - Minimal tillage helps maintain soil organic matter
- Small farm – Wanna B Farms
 - Rotation with cash crops and cover crops
 - Cover crops, compost and manures add organic matter
- Mid-scale farm – Gittin’ There Farms
 - Rotation with cash crops and cover crops
 - Cover crops and manures add organic matter

Learning Activity – Soil Organic Matter

- Soil organic matter in:
 - forest,
 - well managed pastures,
 - conventional tilled, and
 - conservation till or organic soil.
- Discuss color differences and the amount of soil pores and roots in each

Fertility and Georgia Soils

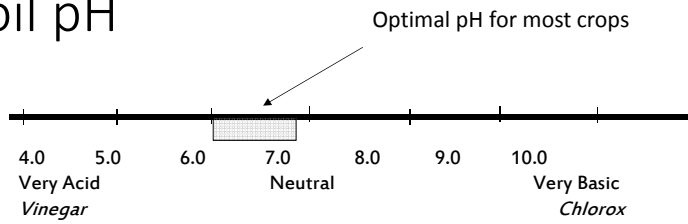
- Highly weathered, low CEC (cation exchange capacity)
- Very acidic (pH<6), a lot of aluminum and iron, not a lot of calcium, potassium, etc.



Fuquay soil series
Coastal Plain

Cecil soil series Piedmont

Soil pH



- Soils in GA naturally acidic
 - Subsoils as low 4.5 or 5.0
- Roots don't like pH below 5.5

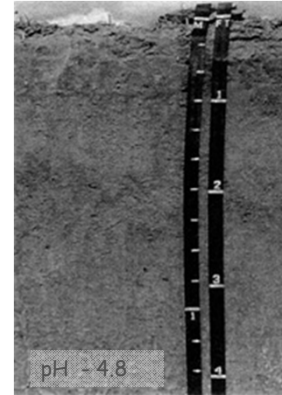


Photo: USDA

Tifton soil series
Coastal Plain

Plant Nutrients

• Macronutrients

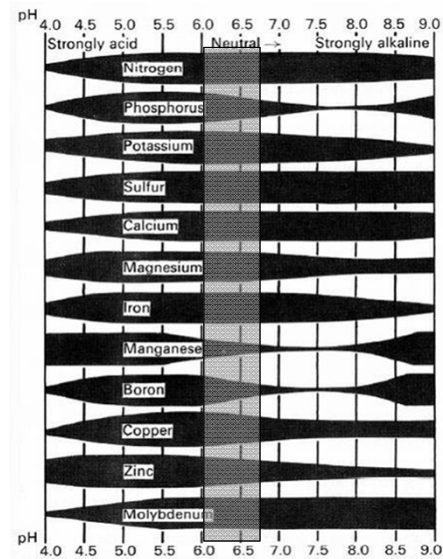
- Nitrogen (N)
 - Phosphorus (P)
 - Potassium (K)
 - Calcium (Ca)
 - Magnesium (Mg)
 - Sulfur (S)
 - Carbon (C)
 - Hydrogen (H)
 - Oxygen (O)
- Soil
- Atmosphere/
water

• Micronutrients

- Boron (B)
 - Chlorine (Cl)
 - Copper (Cu)
 - Iron (Fe)
 - Manganese (Mn)
 - Molybdenum (Mo)
 - Nickel (Ni)
 - Zinc (Zn)
- Soil

pH and Nutrient Availability

- Target is usually 6.0 to 6.8 (near neutral)
- At these pHs phosphorus and micronutrients most available
- Low pH (<5.5) – aluminum toxicity
- At high pH also decreased nutrient availability



Width of black bar represents nutrient availability

Soil Testing

- Many labs, many different types of tests
- Pick a lab and stay with it
- Try to sample at the same time each year
- Take a representative sample
- Use test to look at long term trends



Soil Tests from UGA

- Major plant nutrients:
 - Nitrogen
 - Phosphorus
 - Potassium
- Routine test gives information on **plant available** nutrients
- Have to request additional test for soil organic matter
- Nitrogen NOT tested
 - Fertilizer recommendations based on conventional field trials

THE UNIVERSITY OF GEORGIA
COOPERATIVE EXTENSION

Soil, Plant, and Water Laboratory
2400 College Station Road
Athens, Georgia 30602-9150
Web site: <http://aesl.ces.uga.edu>

Soil Test Report

(CECSA Signature)

Sample ID				Lab Information				Contact			
Client Information				Lab #23821				Soil, Plant, and Water Laboratory			
Keith Harris				Completed: 12/19/2007				2400 College Station Road			
Sample: organic plot				Printed: 01/29/2008				Athens, GA 30602			
Crop: Lettuce, fresh market								ph: 706-542-5350			
								e-mail: sciltes@uga.edu			

Mellich 1 Extractant

Nutrient	Soil Test Value	Soil Test Units
Phosphorus (P)	44	lb/acre
Potassium (K)	134	lb/acre
Calcium (Ca)	1363	lb/acre
Magnesium (Mg)	124	lb/acre

UGA Lime Buffer Capacity Method*

Nutrient	Soil Test Value	Soil Test Units
Zinc (Zn)	3	lb/acre
Manganese (Mn)	24	lb/acre
pH *	6.6	
Lime Buffer Capacity (LBC)	181	lb/acre

Recommendations							
Limestone	Nitrogen (N)	Phosphate (P ₂ O ₅)	Potash (K ₂ O)	Sulfur (S)	Boron (B)	Manganese (Mn)	Zinc (Zn)
8 tons/acre	125-150 lb/acre	80 lb/acre	90 lb/acre	10 lb/acre	1 lb/acre	-	-

Recommended pH: 6.0 to 6.5

*For information on how the Soil, Plant, and Water Laboratory measures and reports pH and makes lime recommendations, see <http://aesl.ces.uga.edu/publications/soiltec>.

Nitrogen (N) rates will vary depending on rainfall, soil type, irrigation, plant population and method and timing of applications.

For early growth stimulation apply a pop-up fertilizer using 100 to 150 pounds of 10-34-0 or similar material per acre. Apply the fertilizer 2 to 3 inches to the side of the seeds or plants and 2 to 3 inches below the seeds or roots.

Sulfate of potash magesia may be used to supply a portion of the recommended potash (K₂O) and to also supply magnesium (Mg) and sulfur (S).

For more efficient use of fertilizer split the applications, applying one-third to one-half down (banded or incorporated in the bed) and the remainder in 1 to 3 applications. If the fertilizer is broadcast, increase the application rates of phosphate (P₂O₅) and potash (K₂O) 1½ to 2 times.

NOTE: The amount of nitrogen (N), phosphate (P₂O₅), and potash (K₂O) actually applied may deviate 10 pounds per acre from that recommended without appreciably affecting yields.

Special Analyses:
Nitrate-Nitrogen (NO₃-N): 14 pounds per acre.
Organic Matter: 1.8% by weight.

Learning for Life
The University of Georgia and Fort Valley State University, the U.S. Department of Agriculture and counties of the state cooperating.
Cooperative Extension offers educational programs, materials and services to all people without regard to race, color, national origin, age, gender or disability.
An equal opportunity/affirmative action organization committed to a diverse work force.

For fertilizer recommendations ask for particular crop or home garden

Lime and fertilizer recommendations based on *amount of plant available nutrients and specific crop*.

Discussion of recommendations

Results for special analysis

Bars represent level of plant available nutrients

THE UNIVERSITY OF GEORGIA
COOPERATIVE EXTENSION

Soil, Plant, and Water Laboratory
2400 College Station Road
Athens, Georgia 30602-9150
Web site: <http://aesl.ces.uga.edu>

Soil Test Report

(CECSA Signature)

Sample ID				Lab Information				Contact			
Client Information				Lab #23821				Soil, Plant, and Water Laboratory			
Keith Harris				Completed: 12/19/2007				2400 College Station Road			
Sample: organic plot				Printed: 01/29/2008				Athens, GA 30602			
Crop: Lettuce, fresh market								ph: 706-542-5350			
								e-mail: sciltes@uga.edu			

Mellich 1 Extractant

Nutrient	Soil Test Value	Soil Test Units
Phosphorus (P)	44	lb/acre
Potassium (K)	134	lb/acre
Calcium (Ca)	1363	lb/acre
Magnesium (Mg)	124	lb/acre

UGA Lime Buffer Capacity Method*

Nutrient	Soil Test Value	Soil Test Units
Zinc (Zn)	3	lb/acre
Manganese (Mn)	24	lb/acre
pH *	6.6	
Lime Buffer Capacity (LBC)	181	lb/acre

Recommendations							
Limestone	Nitrogen (N)	Phosphate (P ₂ O ₅)	Potash (K ₂ O)	Sulfur (S)	Boron (B)	Manganese (Mn)	Zinc (Zn)
8 tons/acre	125-150 lb/acre	80 lb/acre	90 lb/acre	10 lb/acre	1 lb/acre	-	-

Recommended pH: 6.0 to 6.5

*For information on how the Soil, Plant, and Water Laboratory measures and reports pH and makes lime recommendations, see <http://aesl.ces.uga.edu/publications/soiltec>.

Nitrogen (N) rates will vary depending on rainfall, soil type, irrigation, plant population and method and timing of applications.

For early growth stimulation apply a pop-up fertilizer using 100 to 150 pounds of 10-34-0 or similar material per acre. Apply the fertilizer 2 to 3 inches to the side of the seeds or plants and 2 to 3 inches below the seeds or roots.

Sulfate of potash magesia may be used to supply a portion of the recommended potash (K₂O) and to also supply magnesium (Mg) and sulfur (S).

For more efficient use of fertilizer split the applications, applying one-third to one-half down (banded or incorporated in the bed) and the remainder in 1 to 3 applications. If the fertilizer is broadcast, increase the application rates of phosphate (P₂O₅) and potash (K₂O) 1½ to 2 times.

NOTE: The amount of nitrogen (N), phosphate (P₂O₅), and potash (K₂O) actually applied may deviate 10 pounds per acre from that recommended without appreciably affecting yields.

Special Analyses:
Nitrate-Nitrogen (NO₃-N): 14 pounds per acre.
Organic Matter: 1.8% by weight.

Learning for Life
The University of Georgia and Fort Valley State University, the U.S. Department of Agriculture and counties of the state cooperating.
Cooperative Extension offers educational programs, materials and services to all people without regard to race, color, national origin, age, gender or disability.
An equal opportunity/affirmative action organization committed to a diverse work force.

pH, Ca and Mg good
 • no limestone needed

Zinc and Mn good
 • No addition needed

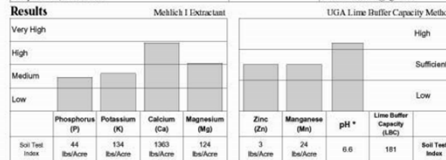
Need P and K
 • Phosphorus - 44 lbs/ac
 • Potassium - 134 lbs/ac

N specific for crop
 • Give recommendations for split applications

Soil organic matter is OK

Soil Test Report

Sample ID Client Information Keith Harris		Lab Information Lab #21521 Completed: 12/19/2007 Printed: 01/29/2008		Contact Soil, Plant, and Water Laboratory 2400 College Station Road Athens, GA 30602 ph: 706-542-5150 e-mail: scilites@uga.edu	
--	--	--	--	--	--



Soil Test Index

Limestone	Nitrogen (N)	Phosphate (P ₂ O ₅)	Potash (K ₂ O)	Buffer (B)	Boron (B)	Manganese (Mn)	Zinc (Zn)
0 tons/Acre	125-150 lbs/Acre	80 lbs/Acre	90 lbs/Acre	10 lbs/Acre	1 lbs/Acre	--	--

Recommended pH: 6.0 to 6.5

*For information on how the Soil, Plant, and Water Laboratory measures and reports pH and makes lime recommendations, see <http://soil.ces.uga.edu/publications/scilitec>.

Nitrogen (N) rates will vary depending on rainfall, soil type, irrigation, plant population and method and timing of applications. For early growth stimulation apply a pop-up fertilizer using 100 to 150 pounds of 10-34-0 or similar material per acre. Apply the fertilizer 2 to 3 inches to the side of the seeds or plants and 2 to 3 inches below the seeds or roots.

Sulfate of potash magnesia may be used to supply a portion of the recommended potash (K₂O) and to also supply magnesium (Mg) and sulfur (S).

For more efficient use of fertilizer split the applications, applying one-third to one-half down (banded or incorporated in the bed) and the remainder in 1 to 3 applications. If the fertilizer is broadcast, increase the application rates of phosphate (P₂O₅) and potash (K₂O) 1½ to 2 times.

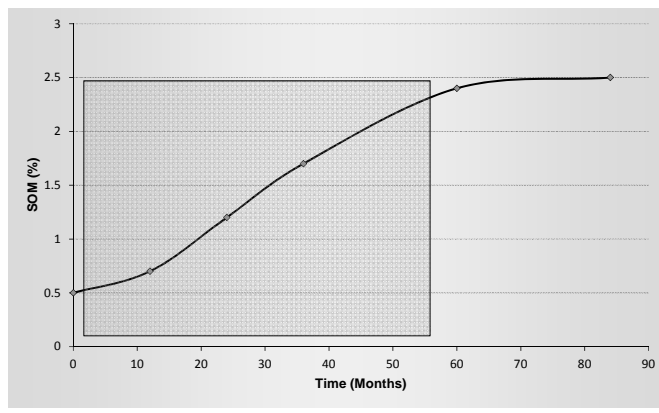
NOTE: The amount of nitrogen (N), phosphate (P₂O₅), and potash (K₂O) actually applied may deviate 10 pounds per acre from that recommended without appreciably affecting yields.

Special Analyses:
 Nitrate-Nitrogen (NO₃-N): 14 pounds per acre.
 Organic Matter: 1.8% by weight.

Considerations for Organic Production

Building and Maintenance Phases

- New or transitioning growers need to build SOM, phosphorus and potash levels
- Can take 3 to 5 years



Julia Gaskin

Soils in Building Phase

- Soil organic matter:
 - <1.5% in Coastal Plain,
 - <2.5% in Piedmont, Ridge & Valley, Mountains
- Low soil pH
- Soil test indices in low or medium range for:
 - Phosphorus (P_2O_5),
 - Potassium (K_2O),
 - Calcium,
 - Magnesium,
 - Zinc,
 - Manganese



Photo: Julia Gaskin

Building and Maintenance Phase

- Building phase
 - Soil test fertilizer recommendations are a good guide
- Maintenance phase
 - Some organic growers reduce fertilizer to account for inherent fertility of the soil

Learning Activity – Interpreting Soil Tests

- Very small farm – Locally Yours Farm
 - Does not soil test - What are the risks?
- Small Farm – Wanna B Farms
 - pH – What does this graph say about pH on this farm?
- Mid-scale farm – Gittin’ There Farms
 - Routine soil test
 - Does this farm need lime?
 - What about P or K?
 - If the soil organic matter is 2%, is this good for a sandy soil?

Taking Soil Samples

- Need clean plastic container and soil probe or trowel
- Collect sample from each field or group of field that are similar
 - Each sample is composite of six or more subsamples
 - Collect from 0-6 inches
- Mix subsamples up thoroughly and put in soil bag
- Submit sample through county extension office
 - Routine sample - \$8



Photo: Julia Gaskin

*Refer to *Soil Testing for Home Lawns, Gardens, and Wildlife Food Plots* in resources
<http://pubs.caes.uga.edu/caespubs/pubcd/C896.htm>

Tillage and A Healthy Soil

- Increases oxygen
- Breaks soil aggregates
- Disrupts soil pores
- Changes water relations
- Relocates nutrients



Photo: Julia Gaskin

- Increases decomposition
- Increases erosion
- Changes community of soil critters

Soil Structure and Tilth

- Worst thing you can do!
 - Till the soil when its **too wet**.
- How to tell
 - Take small portion of soil, squeeze it. If you can get water from it
 - It's **TOO wet!**
 - Make loose ball, bounce in hand or drop on ground, if ball doesn't break apart,
 - Its **TOO wet!**



Soil Structure and Tilth

- The second Worst thing you can do!
 - Till the soil when its **too dry**.
- Tilling soil when too dry shatters soil structure
- How to tell
 - If the soil is hard and a small piece shatters when you crush it
 - It's TOO dry!

Soil Structure and Tilth

- Excessive tillage destroys structure
- Till only when needed for seed bed preparation or weed control
- Use least aggressive tillage possible
- Use cover crops, mulches and transplant

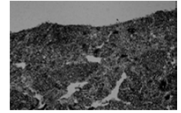


Photo: Bill Miller

Fertility

The ability of the soil to supply nutrients needed for plant growth.

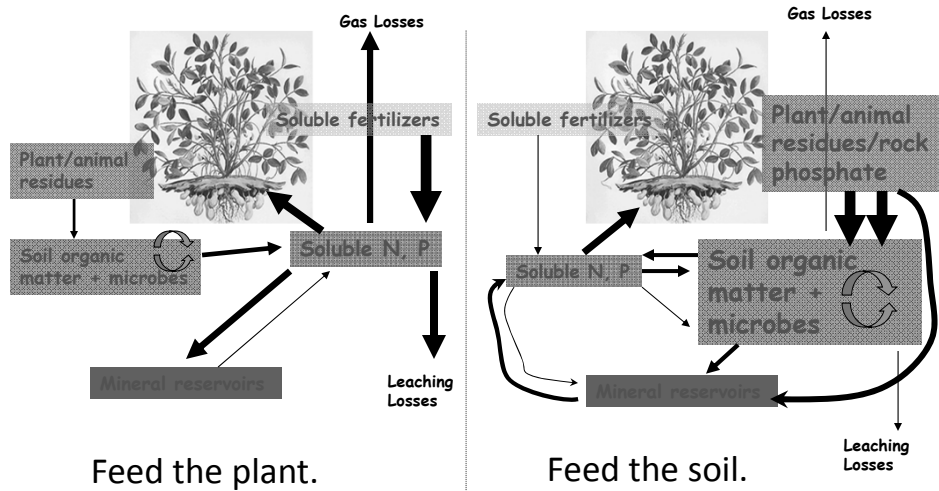
Recognize there are:
physical, biological,
and chemical
components

These are
interrelated.



Photo: Julia Gaston

Two Models for Fertilization



Adapted from Drinkwater and Snapp 2007

Fertilization Strategies

- Depends on:
 - Crops to be grown
 - Fertilizer costs
 - Building or maintenance phase
 - Soil texture – sandy, sandy loam, sandy clay loam, etc.
- Get your soil tested!



How Do We Manage?

- Build up soil reservoirs – soil organic matter and available nutrients
- Get your soil pH right!
- Take care of your structure



Dr. Linda NCSU

Additional Resources

- *Building Soil for Better Crops* – <http://www.sare.org/Learning-Center/Books>.
 - Free pdf online or buy book.
- *Growing Vegetables Organically* – UGA Extension Publication <http://extension.uga.edu/publications/detail.cfm?number=B1011>
 - Good overview of things to consider from a small scale perspective.
- *Soil Biology Primer* – USDA NRCS <http://www.nrcs.usda.gov/wps/portal/nrcs/photogallery/soils/health/biology/gallery/?cid=1788&position=Promo>
- *Soil Management: National Organic Program Regulations* – ATTRA <https://attra.ncat.org/organic.html#soils>
- *Soil Testing for Home Lawns, Gardens and Wildlife Food Plots* – UGA Extension Publication - <http://extension.uga.edu/publications/detail.cfm?number=C896>. How to take a representative soil sample.



JOURNEYMAN FARMER
CERTIFICATE PROGRAM

JOURNEYMAN FARMER CERTIFICATE PROGRAM

This material is based upon work that is supported by the National Institute of Food and Agriculture, U.S. Department of Agriculture, under award number 2015-70017-22861.



Beginning Farmer and Rancher Development Program

Developing the Next Generation
of Sustainable Farmers in Georgia Grant



Very Small-Scale Case Study – Locally Yours Farms

Farm description - Locally Yours Farms is a multiple-parcel site with one acre in production and one building dedicated to storage of the harvested produce. The initial growing space (Site 1) is 1/2 acre, where they grow as many as 12 crops (four per season) including: tomatoes, eggplants, peppers, kale, mustard, collards, onions, garlic, cucumbers, summer squash, bush beans, okra, and mint. Site 1 is divided into five plots, each with four 100 square foot in-ground beds (2,000 sq. ft. total). There is a small fruit-tree orchard and a single compost pile (5ft x 5ft). Each plot is in a year-round rotation of warm and cool season crops. After one year, a second site was added (Site 2) that includes an additional 700 sq. ft. of growing space and two high-tunnels. Site 2 has 20 additional fruit trees. Harvest storage uses five home-style refrigerators located at a third site.

Example Rotation for a Bed:

Year 1

Spring Crop - Spring garlic & onions, mature garlic & onion

Summer Crop – Tomatoes or peppers,

Fall Crop - Kale, collards, mustards

Year 2

Spring Crop – Carrots

Summer Crop – Cucumbers or summer squash

Fall Crop - Lettuce

Year 3

Spring Crop – Beets or Swiss chard

Summer Crop – Bush beans

Fall Crop – Arugula, mesclun mix micro greens

Traditionally, when rotating crops on a very small scale farm, soil amendment such as compost is applied between plantings versus using cover crops. Very small farms grow bio-intensively and never leave a bed exposed for very long. Thus, the benefits of using compost and other amendments provides support in a similar manner to cover cropping, which ultimately allows for consistent, year-round growth of consumable crops.

Labor- Both sites leverage a small group of volunteers ranging from two to three people. These volunteers work for free, though they are allowed to take home culls and low quality fruits and vegetables. In addition to the farm's owner, the business has one full-time staff member who handles harvest, direct sales, and marketing duties. The owner maintains a full-time job, which provides him health insurance and retirement savings. The land is owned by the farmer and gross annual sales average \$20 to 40k.

Markets - Produce is distributed through direct markets (60%) such as an e-commerce website, pop-up farmer's market at pre-schools and a local Whole Foods, and farmers markets. They also sell to commercial clients (40%) such as restaurants.

Infrastructure - Site 1 has a small greenhouse used for growing transplants. Site 2 has two high-tunnels that were built using NRCS cost-share programs. The five refrigerators at Site 3 are in a retrofitted home garage. There is also a double stainless steel sink in the garage. Produce is sorted and cleaned in the garage. They transport the produce to market in an old cargo van.

Irrigation - Irrigation at Site 1 is provided by both a municipal water spigot and a water catchment tank that collects water from a nearby roof. The beds are hand watered using a garden hose and nozzle and/or watering can. At Site 2, irrigation is provided by a well, which is used for both planting and post-harvest cleaning purposes.

Equipment - They have a front-tine rototiller, an array of hand tools, a hand-held sprayer, and five refrigerators. The estimated equipment budget is \$1,300.

Ground Preparation - Site 1 was cleared and leveled using a bobcat. The growing areas were then mechanically tilled with the rototiller. Each bed was amended with compost made on the farm, alfalfa pellets, azomite, rabbit manure or cow manure, and lime. These amendments are added each spring. Winter amendment is azomite and alfalfa pellets. They do not soil test; consequently, they do not know the amounts of phosphorus, potassium or other nutrients available for crops in their soil. The successive years of bed preparation involved double-digging and minimal rototilling. The compost pile is monitored for temperature and turned to keep the temperature high for the first couple of weeks. After the temperature decreases, the pile is cured for a month. The entire farm has also been sheet mulched. Site 2 also uses in-ground beds that are amended with the same fertilizers as Site 1. The entire farm at Site 2 is also sheet-mulched with straw.

Pest Management - Integrated Pest Management techniques, such as companion planting and trap cropping are utilized. Homemade pesticides with garlic, cayenne pepper, and water as well as neem oil applications are also used.

Weed Management - Intensive plant spacing is used to assist with weed control. Additionally, manual methods such as hand-hoeing as well as ecological methods such as laying straw mulch around the base of plants and sheet mulching are used.

Spray Application - Beneficial microorganisms are used for prevention of blight, powdery mildew. Neem oil is another option used for insect problems.

Cover Crop Management – Due to the intensive cash cropping, cover crops are not used. Soil health is maintained with organic amendments and minimal tillage.

Planting - Most of the summer crops are transplanted by hand and the winter crops are direct seeded in a seed bed and then transplanted into the permanent beds by hand.

Small Farm Case Study – Wanna B Farm

Farm Description – Wanna B Farm is a 10-acre farm that has 5 acres of open land and a small house. The farmers rent the land and house for \$10,000/year. They grow certified organic vegetables on 0.5 acres at a given time, but have a total of 2 acres of cultivated suitable for vegetables. During some seasonal periods, there is an overlap of crops. For example, in the spring, the summer plots are planted while they are still harvesting the cool season crops. They also grow about ¼ acre of herbs which are a combination of perennials and annuals. All crops are directly marketed to consumers; consequently, they grow a mix of vegetables and specialize in unusual, heirloom, and new cultivars. Their primary crops in the summer are squash, tomatoes, beans, peppers, and culinary herbs such as basil oregano and thyme. In the fall and spring, they grow kale, lettuce, cabbage, onions, potatoes, spinach, and carrots. Some of the herbs are dried and sold with other seasonal crops to spread out the herb crop income.

Cover Crops and Rotations—The goals for the cover crops are: to have at least one cover crop between cash crops, to vary species used and seasons used to help break pest cycles, particularly weed population, and to allow time for a cover crop to grow to a decent size, get mowed and remain on ground as a mulch once mowed, prior to tilling in.

Example Rotations:

- 1) Buckwheat> Winter Squash/Pumpkins> Oats/Austrian Winter Peas
- 2) Tomatoes/Squash/Okra/Beans> Oat/Winter Pea> Sunn Hemp> Kale/Broccoli/Lettuce/Carrots/collards/Beets> Rye
- 3) Field Peas> Oats/Winter Pea> Kale/Collards/Broccoli/Lettuce> Buckwheat> Tomatoes/Squash/Okra/Beans

One frequent rotation for the herb plot is a crop of oats (seeds collected and sold to customers to make teas) in during the cool season and basil in the summer.

Labor—Farmer Joe works at the farm full-time. His wife is a schoolteacher and this provides medical insurance and retirement for the family.

Markets – Fifty percent of the produce is sold through a small CSA and 50% is sold at a farmers’ market and at a self-serve farm stand at the farm. The CSA uses a box per week model. Members pay up front for each 20-week season. The share price is \$350/share per family-size box/week. Payments are made in advance of receiving the product. They usually sell 30 shares per season. The combined gross sales are around \$42,000/year. They make extensive use of Facebook and website to keep customers abreast of crops in season.

Infrastructure—The rented land has a well that has a good flow (yields 10 gpm) but also has a lot of sediment, which requires a T-style filter (\$300 annual). The filter is a limiting factor in expansion. They have acquired two used 16’ x 50’ hoop houses that can be moved (\$1500 initial, \$200 annual) for season extension. They also have a used 16’ x 25’ hoop house with electric outlet for space heater (\$500 initial, \$100 annual) for growing transplants. For post-harvest cooling, they found a portable tool shed on Craigslist for \$100, insulated it and installed CoolBot AC.

Irrigation - They have put money into irrigation because crop production was so erratic without it. They rented a trencher and installed 1” PVC pipe to each plot (\$1,000 initial cost). They also installed in-line drip

tubes with emitters spaced 12" apart, ½ gpm within the plots (\$10,000 initial cost). All crops are irrigated with drip to save water, except for small seeded crops like lettuce and carrots. This also helps keep food safety problems to a minimum.

Equipment - They have a 10hp walk behind electric start tractor with tiller, rotary plow, brush mower (\$6,000 initial cost). They use an push seeder + broadcast seeder for most direct seed planting (\$125 initial). Fortunately, they have a neighbor with a tractor, tiller, chisel plow and disc for initial field preparation. They pay her \$200 for ground preparation. They also have a variety of basics tools such as wheel hoe, hoes, shovels, and rakes (\$600 initial cost). They use a backpack sprayer (2) + 30 gallon diaphragm battery powered pump w/ 30' hose (\$750 initial) for spot spraying of pesticides. They also use 30-gallon sprayer (powered by tractor) for larger applications.

Ground Preparation - Before the current farmer started working the land, the open land was left fallow and mowed once a year. Before that, the land was in fescue pasture, which has left the soil reasonably stable, with some organic matter, but with a tremendous weed bank of weed seeds. Each time the fields are tilled, new weeds emerge, however, after a year and half of cover crops, the weeds are beginning to become manageable. The old pasture had clayey soils with a low soil pH (5.6 very acidic). They have limed the field every year and it has slowly come up to 6.2 which has made phosphorus and other nutrients more available. Soil preparation consisted of mowing the cover crop, letting it dry on the ground and then dragging the cultivated plots with a small chisel plow and then tilled with the rotary tiller on the 30 HP tractor (borrowed from neighbor). The shaping of raised beds (32' wide) is accomplished with the BCS rotary plow and/or tiller. This past year, the farmer has experimented with skipping the tilling by tractor and relying in the rotary plow on the BCS to break up the soil and shape beds in one pass. This has reduced over-tilling and reduced the reliance on a tractor for field preparation.

Pest Management-

Weeds: Cover crops are used to suppress weeds when a cash crop is not grown. Right now, the cover crops are mowed with walk behind tractor mower, although they are investigating specially designed crimper for no-till so they could leave the cover crop on the soil surface and transplant into it without disturbing the soil. They also make extensive use of a wheel hoe to manage weeds between the rows and hand hoes to keep weeds out of the beds and in the rows. They are experimenting with heavy-duty landscape fabric, as a mulch and weed barrier that can be re-used year to year.

Insects: They scout for insect damage and if need be spot spray with sprayer using OMRI-approved insecticides. They use pan and sticky traps to monitor and trap insects to determine what type of insects are present and if these are an economic problem.

Disease: Resistant cultivars are used when possible and the crop rotation is closely managed to reduce disease pressure. In some cases, straw mulch or landscape fabric is used to reduce soil splashing. There is no overhead irrigation, except micro-spray for small seeded lettuces and carrots.

Cover Crop Management - Cover crops are planted as soon as each field plot is harvested. After as much of the spent crops are removed, the field is mowed, then dragged with the tractor-mounted chisel plow (borrowed). For some crops, that is all the field preparation before broadcasting cover crop seed. For some cover crops, the field is tilled prior to planting.

Planting

As many of the vegetable crops as possible are transplanted by hand. The direct seeded crops for the CSA like turnips are planted with a push seeder.

Mid-Scale Case Study – Gittin’ There Farms

Farm description – Gittin’There Farms has 14 acres in vegetable production. The land includes two fields, Bottom Field and Front Field, and a farm house where the farmer and his family live. The farm house is right next to the Bottom Field and over ¼ mile away from the Front Field. The farm house has two bedrooms, a kitchen, one bathroom, an outdoor handwashing station, a produce washing station with well water, and a root cellar where they sometimes store produce. The well water was tested when the building was first established.

Crops-The land was a family farm that had not been farmed for 10 years until the younger generation took it over. The farm began with the Bottom Field, 2 acres, that focused on direct marketing of crops. The Bottom Field grows up to 20 crops in a given year, though typically 6-10 in a season with several varieties of each crop. In spring/summer their crops are squash (yellow and zucchini), cucumber, snap beans, southern peas, tomato (several varieties), pepper (several varieties), eggplant, sweet corn (successional plantings to extend harvest) and sweet potato. Sweet corn constitutes 1/2 acre and is used as a good rotation crop between cucurbits and solanaceous crops of tomato, peppers, and eggplant. Fall and winter crops include greens (kale, turnip, mustard and collards), broccoli, potatoes (late winter/early spring), beets, carrots and green onions. The field is divided into eight 1/4 acre plots that have a complex rotation between plant families and summer and winter cover crops. In addition to grain and legume cover crops, some parts of the fields are sown in buckwheat and/or sweet alyssum for pollinator and beneficial insect habitat. Strips of sunflowers are planted and harvested to give to customers at the farmers market. In addition, these flowers can also be used by pollinators.

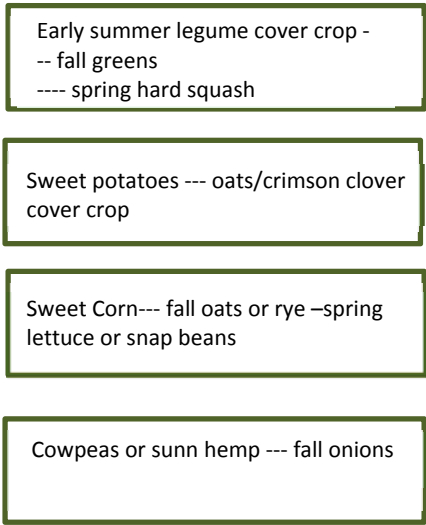
After five years, they expanded to Front Field, 12 acres, which is divided into four 3-acre fields in a simplified rotation that focuses on a wholesale market. Major crops for the Front Field are fall greens, spring lettuce, snap beans and hard squash, summer sweet potatoes and sweet corn and fall-planted onions. They focus on these crops because most of these are easily direct seeded and the greens, snap beans, and corn can all be cooled using their old hydrochiller. The onions, sweet potatoes and hard squash can be cured and have easy storage requirements for wholesaling. These major crops are interspersed with cover crop to maintain soil organic matter, suppress weeds and provide nitrogen.

Example Rotation for Front Field Farm:

- Yr 1: Early summer legume cover crop – fall greens (kale, collards, etc) – spring hard squash
- Yr 2: Sweet potatoes– winter grain/legume mix cover crop
- Yr 3: Sweet corn – Late summer buckwheat cover crop - Winter grain cover crop – Spring snap beans or lettuce
- Yr 4: Summer legumes – onions

This rotation gives them summer income from sweet corn, fall income from sweet potatoes and fall greens, and spring income from lettuce, snap beans, and hard squash. The use of cover crops has slowly improved soil organic matter. Soil organic matter in the Front Field was initially 0.7%. Over time they have brought in up to 1.75% which is excellent for their sandy soils. They have to constantly work

June 1 to June 1
Year 1



to maintain the right pH and amount of nutrients. Nitrogen and potassium are particular challenges because these are rapidly lost below rooting zone in their sandy soils. They use commercial fertilizer to help maintain these nutrients in the soil.

Labor-They both work on the farm and hire additional summer labor. They were not able to purchase medical insurance until recently and saving for retirement has been difficult.

Markets – The farm started direct marketing at a farmers’ market. This gave them time to learn how to grow crops and what worked best on their farm. It also built their clientele and after several years they expanded their direct marketing to a multi-farm CSA. Five years later they expanded to wholesale markets of locally-focused grocery chains. The produce from the Bottom Field is direct marketed through a multi-farm CSA along with USDA #2s from the Front Field. The Front Field USDA #1s are sold wholesale through a distributor.

Infrastructure –There is a small green house to produce transplants. The well for their house also supplies water for post-harvest produce cleaning. The farm has converted an old barn to a packing shed that has stainless steel counters and a triple sink from a restaurant that has gone out of business. They originally walled off a small room and installed a CoolBot AC. When they decided to go into business for wholesale production they built a hydrocooler from a used milk chiller and chose to purchase a walk-in cooler from a failed restaurant.

Irrigation - Initially they tried to water with just garden hoses and sprinklers in the 2-acre CSA field – this was inadequate for their needs. Therefore, they invested in digging a small pond which was refilled using an existing 12’ well. While not an ideal solution, as the well has a limited capacity, it was the best solution they had at the time. They purchased a used irrigation pump and traveling gun to water their 2 acre field at first. When they expanded they moved to drip irrigation as much as possible to conserve water and reduce food safety concerns although they will use the irrigation gun to water some crops such as sweet potatoes and snap beans which are planted on a tighter row spacing and would require more drip tape per acre than some other crops. They were able to obtain a cost share from NRCS to install pipes for drip irrigation. They may also still use the reel irrigation system to get the cover crops off to a fast start.

Equipment – They have a 75 HP 4 wd tractor (\$20K used), a used turning plow (\$1K), an old harrow, a planter (\$3k), a small plastic layer, and a flail mower (\$4500). They recently acquired a rotary spader (\$20), which can reduce the number of trips through the field. Because they had planned on buying a spader at some point, when they bought their tractor they specifically chose one with a creeper gear so that they could run slow enough for the spader but maintain high enough rpms to turn it. They bought a used 2 row rolling cultivator which is used to help control weeds (\$1800). They bought a drip tape layer that was custom made to bury drip 2-3 inches below the soil line (\$1600). They use a finger-style used tobacco transplanter that was purchased from a local retired tobacco farmer (\$300). They were able to buy a small 8 row boom sprayer with a 200 gallon tank that they later modified with drop nozzles (3’ rows) from a local agriculture supplier for \$1900. It will only spray 4 rows planted on 6’ centers at a time. They also have a backpack sprayer. It has taken them some time to accumulate this equipment.

Ground Preparation - They have always used cover crops, so initially, they mowed cover crops with a rotary mower then turned them in with the turning plow. This required several additional passes with the harrow to prepare the beds, which decreased the benefit they saw from the cover crops on

increasing soil organic matter and structure. The purchase of the spader allows them to incorporate the cover crop and condition the soil in most cases with one pass.

Pest Management -

Weeds: Cover crops are used to suppress weeds when a cash crop is not being grown. They try to make one pass with the spader to incorporate the mowed cover crops and then make a shallow cultivation with a field cultivator to destroy the tiny weeds just before planting or transplanting. Plastic is also used to control weeds in the long season crops like onions being grown for wholesale. Wheel hoes and hand hoes are also used particularly in the 2-acre field with many crops for the CSA. They do spray with glyphosate for some hard to control weeds.

Insects: They scout for insect damage and spray if needed. They also use pan and sticky traps to monitor and trap insects to determine what type of insects are present and if these are an economic problem.

Disease: Resistant cultivars are used when possible and the crop rotation is closely managed to reduce disease pressure. The drip irrigation reduces soil splashing. They are diligent about rouging out infected plants and burning any debris to prevent the buildup of diseases. They do not generally spray for disease control.

Cover Crop Management - Initially, they used a rotary mower in the Bottom Field, but this tended to leave the cover crop in clumps so they invested in a flail mower. All the legume and legume/grain cover crops are flail mowed and turned in. In the Front Field, cover crops are seeded with a broadcast seeder and then lightly harrowed in so planting rates are high. They would like to buy a drill but have not been able to afford it yet. The same method is used if bigger blocks are open in the Bottom Field. If there are only smaller sections needing to be planted, they broadcast and rake in the seed.

Planting

Most of their cash crops are direct seeded. Any transplanted crops are planted with a used tobacco finger-style transplanter.

Session 1: Resource Page

Building Soil for Better Crops

<http://www.sare.org/Learning-Center/Books>

Free pdf online or book for purchase

Growing Vegetables Organically

<http://extension.uga.edu/publications/detail.cfm?number=B1011>

UGA Extension Publication B 1011, Good overview of things to consider from a small scale perspective.

Soil Biology Primer – USDA NRCS

<http://www.nrcs.usda.gov/wps/portal/nrcs/photogallery/soils/health/biology/gallery/?cid=1788&position=Promo>

Soil Management: National Organic Program Regulations

<https://attra.ncat.org/organic.html#soils>

ATTRA IP270, Free pdf online or book for purchase

Soil Testing for Home Lawns, Gardens and Wildlife Food Plots

<http://extension.uga.edu/publications/detail.cfm?number=C896>

UGA Extension Publication C 896, How to take a representative soil sample.

NOTES:



Small Fruit and Vegetable Production
Soil Fertilizers & Amendments, Cover
Crops, Groundcovers for Small Fruit

Session Two
Facilitator Notebook

Session 2 – Soil Fertilizers & Amendments; Cover Crops; Groundcovers for Small Fruit Facilitator Agenda

Homework Discussion (5 min)-Case studies

Ask how many people read the Case Studies. Remind them that they will be used as examples throughout the training.

Soil Fertilizers & Amendments (35 min-David Berle, Horticulture Dept., University of Georgia)

- Fertilizer basics- fertilizer grades, commonly used organic and inorganic fertilizers
- Soil amendments-composts, why they are important, when to use compost, do-it-yourself test for compost quality
- Records needed of soil amendments and fertilizer-resources and/or examples

Learning Objectives:

- Calculate how much N, P₂O₅, K₂O is in 10-10-10
- Give an example of an organic fertilizer that can supply potassium
- Recognize the characteristics of a well stabilized compost

Learning Activity (30 min)-Fertilizer Calculations Soil Test and Fertilizer Application Worksheet

The Soil Test and Fertilizer Application Worksheet is meant to give the participants practice using a soil test to calculate the amount of a certain type of fertilizer they would need to apply.

1. Have the participants pull out the Gittin' There Farms Soil Test from the Session 1 section of their notebook. Point out the recommendations table in the middle of the page, and that the units are in lbs/ac of Nitrogen, Phosphate, and Potash.
2. At the top of the worksheet, there are three equations that explain how to calculate the amount of fertilizer to apply from the recommendation given and the fertilizer grade (N-P-K numbers). Explain that the recommendation comes from the soil test page and is dependent on the crop requested.
3. Give the class 10 minutes to use the Gittin' There Farms Soil Test to answer the question on the worksheet.
4. Go over the answers with the class. The worksheet and answers are located after these facilitator notes.

Activity You Can Do at Home- Read Extension Bulletin-How to convert an Inorganic Fertilizer Recommendation to an Organic One. This pdf is located after Section 2 material.

Cover Crops (30 min, Julia Gaskin, Crop & Soil Dept., University of Georgia)

- Major cover crop categories-winter, summer, grain, legumes, brassicas, others
- Benefits of cover crops with examples of cover crops best for a particular function
- Legumes and nitrogen; how to maximize N, effective nodules
- Records for cover crop examples

Learning Objectives:

- List three reasons you might want to use cover crops
- Name three major plant families used for cover crops

Learning Activity (20 min)-Cover Crop Jeopardy

Ideally, you will have two buzzers or bells and a timer for this activity. You will also need a pad to record the points for each team and the answer sheet.

Divide the group into two teams. Give each team a buzzer or bell. Pull up the Cover Crop Jeopardy power point. Ask Team 1 to select a category and points. Click on their choice. A description will come up on the slide. The Team should ask the question for which this is the answer. If the first Team cannot ask the right question in 15 seconds. The second Team gets 10 seconds to get the right question. Click on the Question box at the lower left corner to display the right question. Award points to the team that gets the right question. Click on the Home button in the lower left corner to return to the Cover Crop Jeopardy Board.

The second team gets to pick the next category and points. Repeat the process. Once all category/points boxes have been used. Total points and announce the winner!

Homework Assignment

Groundcovers for Small Fruit (15 min, David Berle, Horticulture Dept., University of Georgia) – Give the class the link for this webinar to view at home

<https://vimeo.com/155724749>

Learning objectives:

- Identify groundcovers that are beneficial for reducing weeds in small fruit production

Soil Test and Fertilizer Application Worksheet Key

To determine how much fertilizer to use, start with the recommended rate of Nitrogen (N), in lbs. per acre, divided by percent N in fertilizer selected will give you the amount of fertilizer to apply to provide the recommended amount. The same calculation is used for Phosphorus and Potassium. Calculate the amount of fertilizer needed to achieve a recommended rate of a necessary element using the following formulas:

$$\text{Recommended rate of } N \frac{\text{lbs}}{\text{ac}} \div N\% \text{ in fertilizer} = \text{Amount of Fertilizer to apply } \frac{\text{lbs}}{\text{ac}}$$

$$\text{Recommended rate of } P \frac{\text{lbs}}{\text{ac}} \div P\% \text{ in fertilizer} = \text{Amount of Fertilizer to apply } \frac{\text{lbs}}{\text{ac}}$$

$$\text{Recommended rate of } K \frac{\text{lbs}}{\text{ac}} \div K\% \text{ in fertilizer} = \text{Amount of Fertilizer to apply } \frac{\text{lbs}}{\text{ac}}$$

Example

Look at the Soil Test Report for *Gittin' There Farms*.

Nitrogen

Based on the soil test for *Gittin' There Farms* the recommended amount of Nitrogen for Kale is 175-225 lbs. /ac, or average of 200 lbs/ac N. If the Nitrogen fertilizer to be applied is ammonium nitrate (34-0-0), which is 34% Nitrogen, then to provide 200 lbs/ac N:

$$\text{Use the equation: } 200 \frac{\text{lbs}}{\text{ac}} N \div 0.34 = \mathbf{588 \frac{\text{lbs}}{\text{ac}} \text{ Ammonium nitrate}}$$

Phosphorous

The recommended amount of Phosphorus (P₂O₅) for *Gittin' There Farms* is 20 lbs/ac. If the Phosphorus fertilizer material to be applied is Bone Meal (0-11-0), then to provide 20 lbs/ac P₂O₅:

$$20 \frac{\text{lbs}}{\text{ac}} P_2O_5 \div 0.11 = \mathbf{182 \frac{\text{lbs}}{\text{ac}} \text{ Bone Meal}}$$

Potassium

The recommended amount of potassium (K₂O) for *Gittin' There Farms* is 150 lbs /ac. If the Potassium fertilizer material to be applied is Potassium Sulfate (0-0-51), then to provide 150 lbs /ac K₂O:

$$150 \frac{\text{lbs}}{\text{ac}} K_2O \div 0.51 = \mathbf{294 \frac{\text{lbs}}{\text{ac}} \text{ Potash}}$$

Questions

1) Use the Gittin' There Farms soil test to answer the following questions. If 200 lbs/ac of (10-10-10) is applied to achieve the required P_2O_5 , how much N and K_2O will also be applied? How much more N and K_2O will be necessary to meet the recommendations (use the 175 lbs N/ac for nitrogen and 150 lbs K_2O for potassium)?

- a. To calculate how much N will be applied, multiply the amount of fertilizer by the N% of the fertilizer.

200 lbs/ac Fertilizer x 0.10 = 20 lbs/ac N will be applied

- b. To calculate how much K_2O will be applied, multiply the amount of fertilizer by the K% of the fertilizer

200 lbs/ac Fertilizer x 0.10 = 20 lbs/ac K_2O will be applied

- c. To calculate how much more N will be needed, take the recommended N rate of 175 lbs N/ac and subtract the amount of N that will be applied, which you just calculated in part a.

200 lb/ac N - 20 lbs/ac N = 180 lbs/ac N is still needed

- d. To calculate how much more K_2O will be needed, take the recommended K_2O (150 lbs K_2O /ac) and subtract the amount of K_2O that will be applied, which you just calculated in part b.

150 lb/ac N – 20 lbs/ac N = 130 lbs/ac K_2O is still needed

Learning Activities Notes to Facilitators

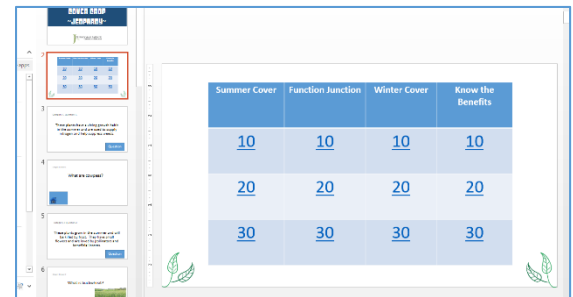
Cover Crop Jeopardy

Considerations for this Learning Game

Slide #36 – Activity – Cover Crop Jeopardy (20 minutes)

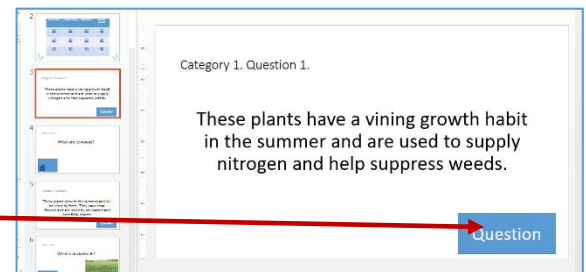
1. The game works only once you have begun the slide show.
2. The first slide introduces the game. Much like Jeopardy there are teams and each team gets to buzz in, answer a question, and then choose the next question and point combo they'd like to try.
3. The second slide is the 'home' slide. This interactive grid automatically takes you to the question the participant has chosen.

Home Page:



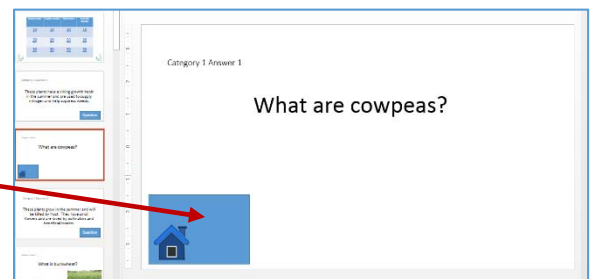
4. Once you click on the clue box you will be taken to the 'answer'. Read the clue and then teams can try and 'buzz' in first. There is a blue box in the lower left corner that has the 'question' that you will click to check the teams answer.

Click Here



5. The question slide has a blue box on the right lower corner of the screen and is the 'home' button that you click in to take you back to the main board. (There is an icon to indicate that is the 'home' box but click in the blue box area to be linked back to the 'home' page.)

Click Here



6. Keep track of the points each team earns.
7. The team with the most points wins!
8. **Have fun!**



Small Fruit and Vegetable Production



Session 2 Soil Fertilizers and Amendments

David Berle, Associate Professor
Horticulture Department
University of Georgia



Learning Objectives

- Calculate amount N, P₂O₅, K₂O in a bag of 10-10-10
- Provide examples of organic fertilizers
- Recognize characteristics of a well-stabilized compost



Fertilizer

- The most common nutrients needed for fruits and vegetables
 - Nitrogen (N)
 - Phosphorus (P)
 - Potassium (K)
- Fertilizer comes in bags
- Fertilizer bags list the amount of N, P and K



What's in the bag?

- The amount of each nutrient is listed on the bag as a PERCENT of the total contents
 - Example: 5-10-10 has 5% N, 10% P_2O_5 and 10% K_2O
 - Example: Feather meal has 13% N so its listed as 13-0-0



Photos: <http://goodthegarden.ucdavis.edu/>



What's in the bag?

- To calculate the pounds of nitrogen (N) in a 50-lb bag of 10-10-10 fertilizer:
 - Multiply 50 by 0.10.
 - $50 \text{ lbs} \times 0.10 = 5 \text{ lbs of N}$
- Use the same method for calculating the amounts of phosphate (P_2O_5) and potash (K_2O)



What's in the bag?

- What else is in the bag? Filler, typically limestone, sand or clay as a carrier.
- For organic fertilizers, the "extra" material is usually other elements or complex materials bound to the fertilizer component



JOURNEYMAN FARMER
CERTIFICATE PROGRAM

Conventional and organic fertilizers

- Common fertilizers used in fruit and vegetable production on a small farm include: 10-10-10, 34-0-0, 0-46-0, 16-4-8
- Organic fertilizers usually come with single nutrient
 - Nitrogen: Feather meal (13-0-0), Blood meal (12-0-0), Alfalfa meal (3-0-0)
 - Phosphate: Colloidal phosphate (0-20-0), Bone meal (2-14-0)
 - Potassium: Green sand (0-0-7), Granite dust (0-0-5)
- Organic low total available nutrients, release slowly



JOURNEYMAN FARMER
CERTIFICATE PROGRAM

Amount of organic fertilizer to use

- Total amount of each nutrient based on soil sample
- First, determine amount of N, P₂O₅ and K₂O needed
- Second, for areas over ¼ acre, select single nutrient materials



Photo: Robert Tate

JOURNEYMAN FARMER
CERTIFICATE PROGRAM

Amount of Organic Fertilizer to Use

• Nitrogen

- Consider any carry over N from previous cover crop
- Consider N in any amendment added like compost
- Select least expensive material (shipping is expensive)



JOURNEYMAN FARMER
CERTIFICATE PROGRAM

Amount of Organic Fertilizer to Use

• Nitrogen

- Divide amount recommended by percent in bag (see example below)
 - Amount recommended is 200 lbs N per acre
 - Blood meal (12-0-0) or 12% N
 - $200 \text{ lbs} / 0.12 = 1,667 \text{ lbs. Blood meal per acre, or}$
 - 38 lbs per 1,000 sq. ft.
 - (1,667/43.5 because 43,560 sq. ft. per acre)



Bloodmeal (12-0-0)
Photo: Julia Gaskin

JOURNEYMAN FARMER
CERTIFICATE PROGRAM

Amount of organic fertilizer to use

• Phosphate

- Consider that P stays in a clay soil a long time
- Consider P in any amendment added like compost
- Select least expensive material (shipping is expensive)
- Divide amount recommended by percent in bag (see example below)
 - Amount recommended is 20 lbs P per acre
 - Cal Phosphate (0-20-0)
 - $20 \text{ lbs} / .20 = 100 \text{ lbs. CalPhosI per acre, or}$
 - 2.25 lbs CalPhos per 1,000 sq. ft. (100/43.5 because 43,560 sq. ft. per acre)

JOURNEYMAN FARMER
CERTIFICATE PROGRAM

Amount of organic fertilizer to use

- Potassium
 - Consider K in any amendment added like compost
 - Select least expensive material (shipping is expensive)
 - Divide amount recommended by percent in bag
 - Amount recommended is 150 lbs K_2O per acre
 - Greensand (0-7-0) or 7% K_2O
 - $150 \text{ lbs} / 0.07 = 2,142 \text{ lbs. Greensand per acre, or}$
 - 49.25 lbs per 1,000 sq. ft.
 - $(2,142/43.5 \text{ because } 43,560 \text{ sq. ft. per acre})$



Amount of organic fertilizer to use

- In GA, recommendations for Sulfur and Boron are NOT based on basic soil analysis, but on a standard
- Sulfur
 - If applying, use Elemental Sulfur (90% S) 10 lbs/ac, so
 - $10 \text{ lbs} / 0.90 = 11 \text{ lbs/ acre or } 0.25 \text{ lb per } 1,000 \text{ sq. ft.}$
- Boron
 - Only needed for certain crops- Broccoli for example
 - Very small amount, 2 lbs per acre
 - If applying, use Sodium Calcium Borate (10% B) 2 lbs/ac, so
 - $2 \text{ lbs} / 0.1 = 10 \text{ lbs/ acre or } 0.25 \text{ lb per } 1,000 \text{ sq. ft.}$



Amount of conventional fertilizer to use

- Conventional fertilizers are cheaper than organic
- Blends are more common than single ingredient fertilizers
 - Exception is Nitrogen fertilizer Ammonium Nitrate (34-0-0)
- Consider
 - Soil sample results
 - Carry over from cover crops
 - Nutrient content of any soil amendments



Amount of conventional fertilizer to use

- If only Nitrogen required, select single ingredient fertilizer
- If N + P + K needed, use 10-10-10 (or 20-20-20)
- If N + P needed (no K), use either 10-10-10 or 34-0-0 + 0-46-0
- If N + K needed (no P), use 10-10-10 or 34-0-0 + 0-0-50
- Using a fertilizer with all three nutrients when only one or two are needed is NOT recommended

JOURNEYMAN FARMER
CERTIFICATE PROGRAM

Applying fertilizer

- Broadcast fertilizer over top area, before planting
- Mix into soil to insure contact of roots to fertilizer
 - Nitrogen moves in soil easily
 - Phosphorus does not move in soil
 - Potassium moves fairly easily in soil



JOURNEYMAN FARMER
CERTIFICATE PROGRAM

Soil amendments

- Soil amendments can help fruit and vegetable crops
 - Compost
 - Helps hold moisture in sandy soils
 - Makes good environment for roots
 - Must be aged
 - Avoid amending soil with peat moss (potting soil) or wood chips
 - Un-composted animal manures should be looked at as a fertilizer and used only with proper waiting times

JOURNEYMAN FARMER
CERTIFICATE PROGRAM

Compost

- If possible, include composting program in farm plan
- Compost benefits:
 - increases organic matter (and all the benefits that go with OM)
 - improves water holding
 - increases nutrient exchange capacity
 - provides small amount of nutrients



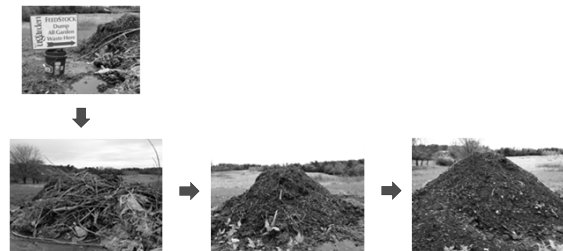
JOURNEYMAN FARMER
CERTIFICATE PROGRAM

How to make compost

- Use mix of greens and browns
- Grind or chop materials place in pile, the smaller the better
- Turn when pile when pile gets hot and starts to cool
- Keep pile moist, but not too wet
- Materials to keep out of pile
 - Large plant parts
 - Very diseased plant, especially tomatoes, squash and cucumbers
 - Noxious weeds like Bermuda grass and nutsedge

JOURNEYMAN FARMER
CERTIFICATE PROGRAM

Stages of Small Farm Composting



Photos: David Berte

JOURNEYMAN FARMER
CERTIFICATE PROGRAM

How to use compost

- Apply aged compost prior to planting and tilled in
 - Apply just like fertilizer
 - Aged compost does not smell bad
 - Aged compost is not hot to the touch
- Use as top dressing, but better benefit if mixed into soil
- Greatest benefit to new ground or poor soils
- Continue adding with each new cash crop until OM level approaches 5%



Suggested “Do It Yourself” Minimum Testing for Good Compost

- Moisture – feel test
- Smell – no ammonia, good “earthy smell”
- pH - strips
- Inerts – sieve and weigh
- Germination – tomato or cress seeds



Learning Activity

- Fertilizer Calculations Worksheet





Small Fruit and Vegetable Production



Session 2 Cover Crops

Julia Gaskin
Sustainable Agriculture Coordinator
Crop & Soil Science Dept
University of Georgia



Learning Objectives

- List three reasons you might want to use cover crops
- Name three major plant families that are used for cover crops



Why use cover crops?

- Grown primarily for soil or ecosystem improvement rather than cash
- Important fertility management tool for farmers
- Negative consequences if managed incorrectly or the wrong species is used.



Black oats winter cover crop



Sunn hemp summer cover crop
Photos: Julia Gaskin



Cover Crop Benefits

- Reduce soil erosion
- Improve soil quality by adding carbon
- Reduce nutrient loss
- Increase water holding capacity
- Improve water quality
- Reduce weed pressure
- Provide habitat for beneficial insects
- Provide nitrogen (legume cover crops)



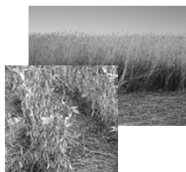
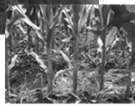
Rye roots and nutrient scavenging
Photos: Julia Gaskin

Thick rye mulch acting as weed control



Challenge !

Finding the right cover crop that fits your rotation and accomplishes your specific purposes.



Photos: Julia Gaskin



Cover Crop Categories

- Major season for growth
 - Winter – planted in fall and killed in the spring
 - Summer – planted in the spring and killed in fall
- Plant family
 - Grains
 - Winter - cereal rye, wheat, oats, black oats,
 - Summer - sorghum, sudangrass, millets
 - Legumes
 - Winter – clovers, winterpeas, vetches, lupines
 - Summer – cowpeas, sunn hemp, velvetbean, pigeon peas
 - Brassicas
 - Winter – radishes, mustards, rapeseed
 - Others
 - Buckwheat, sunflowers



Photo: Julia Gaskin

JOURNEYMAN FARMER
CERTIFICATE PROGRAM

Grains

- Characteristics
 - High biomass (as much as 8,000 lbs/ac)
 - High carbon:nitrogen ratio when mature
- Primary functions
 - Improved soil quality
 - Weed suppression
 - Nutrient scavenging
- Potential problems
 - Nitrogen immobilization
 - High biomass hard to manage



Photo: Jimmy Dixon



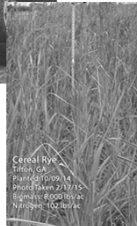
JOURNEYMAN FARMER
CERTIFICATE PROGRAM

Cereal Rye

- Winter annual grass
- Grows rapidly
- Tolerant of low fertility and pH
- Weed suppressing
- Most winter hardy of annual grasses
- Slow to break down
- Deep rooted (recycling nutrients)
- Seed 60 -120 lb/A, in late Sept. - late Nov.



Photo: Julia Gaskin

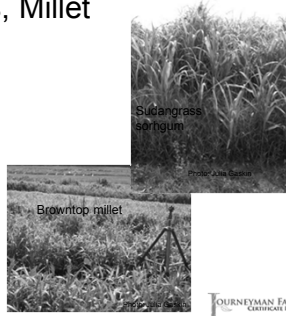


Cereal Rye
Tifton, GA
Planting: 10/20/14
Insect: 2/17/15
Biomass: 8000 lbs/ac
N: 100 lbs/ac

JOURNEYMAN FARMER
CERTIFICATE PROGRAM

Sorghum, Sudangrass, Millet

- Sorghum, sudangrass
 - High biomass (>8,000 lbs/ac)
 - Allelopathic
 - Johnson grass problem
 - Seed May-July 35- 50 lbs/ac
- Millets
 - Moderate biomass
 - Better suited for operations without heavy equipment
 - Attracts birds
 - Seed May- July 10 – 35 lbs/ac



JOURNEYMAN FARMER CERTIFICATE PROGRAM

Legumes

- Characteristics
 - Moderate biomass (4,000 lbs/ac)
 - Fixes nitrogen from atmosphere
 - Low carbon:nitrogen ratio when mature
- Primary functions
 - Provides nitrogen
 - Provides habitat for beneficials (particularly pollinators)
- Potential problems
 - Not good weed suppressants



Photos: Julia Gaslin

JOURNEYMAN FARMER CERTIFICATE PROGRAM

Crimson Clover

- Winter annual 12-20 inches
- 500-5,000 lb/ac
- Up to 140 lbs nitrogen/ac
- Seed Sept – Oct at 12-20 lbs/ac



JOURNEYMAN FARMER CERTIFICATE PROGRAM

Cowpeas

- Seed available
- Good biomass can help suppress summer weeds (5,000 lbs/ac)
- Up to 100 lbs nitrogen/ac
- Seed at May – June at 50-60 lbs/ac



JOURNEYMAN FARMER
CERTIFICATE PROGRAM

Legumes

- Nitrogen fixation from bacteria – Rhizobia spp.
- Need fresh inoculant for best results
- TREAT IT RIGHT!
 - Keep refrigerated before use
 - Don't leave in hot car or sun
 - Follow inoculant instructions
 - Slightly moisten seed and mix inoculant just before planting

JOURNEYMAN FARMER
CERTIFICATE PROGRAM

Rhizobium-Legume Symbioses

<u>Host plant</u>	<u>Bacterial symbiont</u>
Alfalfa	<i>Rhizobium meliloti</i>
Clover	<i>Rhizobium trifolii</i>
Soybean	<i>Bradyrhizobium japonicum</i>
Beans	<i>Rhizobium phaseoli</i>
Pea	<i>Rhizobium leguminosarum</i>
Sesbania	<i>Azorhizobium caulinodans</i>

Source: Dr. Julie Grossman, North Carolina State University
<http://articles.extension.org/pages/64401/legume-inoculation-for-organic-farming-systems>

Both plant and bacterial factors determine specificity

JOURNEYMAN FARMER
CERTIFICATE PROGRAM

Nitrogen in Cover Crop Residues

Grain Species	Ib N / Acre	Legume Species	Ib N / Acre
Barley	35-70	Alfalfa	100-250
Oats	30-70	Crimson clover	50-160
Rye	35-70	Austrian Pea	40-175
Wheat	25-70	White clover	75-140
		Vetch	45-200
		Cowpeas	40-60
		Soybean	35-45

Reeves, 1994



Nutrient Release

- Soil temperature and moisture
- C to N ratio - N mineralization or immobilization by soil microbes
 - < 25 net mineralization (release)
 - > 25 net immobilization (tie up)
- The "woodiness" of the cover crop (Lignin, tannins and polyphenols are resistant to microbial breakdown and slow the rate of decomposition).



Estimating N from Cover Crops

- Need aboveground biomass and nitrogen concentration
- Rule of thumb – 30 to 60% of total N will be available for next cash crop
- Three resources:
 - SARE – Managing Cover Crops Profitably
 - Oregon State Cover Crop Calculator
 - UGA Cover Crop N Calculator



Brassicas

- Characteristics
 - Moderate biomass (lbs/ac)
 - 20:1 carbon:nitrogen ratio when mature
- Primary functions
 - Loosening compaction layers
 - Nematode suppression
 - Early flowering for pollinators
- Potential problems
 - Diseases



PHOTO: JULIA GASKIN
 JOURNEYMAN FARMER CERTIFICATE PROGRAM

Cover Crop Mixtures

- Mix species to add diversity and functions
- Most common is grain/legume
 - Slows nitrogen release to spread it over growing season
 - Can improve weed suppression



Photo: Julia Gaskin

JOURNEYMAN FARMER CERTIFICATE PROGRAM

Maximize Biomass to Maximize Benefits!

- Treat like cash crop
- Good seed bed
- Good seed soil contact
- Timely planting
- Kill as late as possible



JOURNEYMAN FARMER CERTIFICATE PROGRAM

Planting Cover Crops

- Broadcasting
 - Use higher seeding rates
 - Hand broadcast
 - Estimate area you need to plant
 - Calculate lbs of seed needed at correct seeding rate
 - Walk through area using a sowing motion until all seed is put out
 - Spin seeder
 - Follow manufacturers instructions
 - Rake or harrow in seed to get seed/soil contact
 - Water in

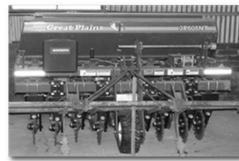


Photo: Julia Gaskin



Planting Cover Crops

- Drills
 - Typically get more uniform stands
 - Sometimes can be rented or can contract with neighbor
 - Use manufacturer settings for rate estimate
 - Use recommended seeding rates



Photos: George Boyhan



Killing Cover Crops

- When to kill?
 - 2 to 4 weeks before planting
- How to kill?
 - Mowing
 - Tillage
 - Rolling and crimping
 - Herbicides



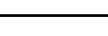
Photo: USDA ARS



Photo: Suzanne O'Connell

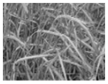


Photo: Julia Gaskin



Choosing a cover crop

1. What is my primary goal or goals?
2. How will I manage it?
3. What is my crop rotation? What is the planting window for the cover crop?
4. Select the best species or mix to satisfy 1 -3.



Photos: Julia Gaskin



JOURNEYMAN FARMER
CERTIFICATE PROGRAM

Step 1. What is my primary goal?



- Address the most important factors limiting productivity and sustainability of your system.
- Possible goals include:
 - Improve nutrient availability and provide nitrogen
 - Improve soil physical properties
 - Reduce erosion, leaching and protect water quality
 - Suppress weeds, pests and diseases
 - Provide beneficial habitat
 - Provide surface mulch



Photos: Julia Gaskin

JOURNEYMAN FARMER
CERTIFICATE PROGRAM

Step 2. How will I manage it?

- Planting – drill or broadcast and rake/harrow in
- Killing:
 - Mowing – Can my mower handle the biomass?
 - Incorporation – Can my tiller or tractor handle turning the cover in OR?
 - Roller crimping – How can I roll it down and leave on surface?



Photos: Julia Gaskin

JOURNEYMAN FARMER
CERTIFICATE PROGRAM

Step 3: What is the crop rotation?



- Identify “window” where cover crop fits
- Minimize conflicts in timing of field operations for cash crops.
- Select species for climatic and soil conditions during the window.
 - e.g.- frost patterns, soil and air temperatures for germination and growth, soil pH.



Photos: Julie Gaskin



Step 4: Select species/mix to meet goals from steps 1 - 3.

- Match the candidates identified in step 1 with characteristics identified in step 2 and 3.
- Remember to consider characteristics you don't want as well as those you are looking for.
- No “perfect” cover crop. Trade-offs will need to be made.
- A final considerations – economic assessment
 - cost and availability of seed
 - labor



What to avoid.....

- Seed production - particularly by cover crops with hard seed - vetch seed remain viable for years and can become a weed.
- Avoid using the same cover crop every year, particularly a single species.
 - Risk build up of populations of competitive weeds, as well as pests and disease organisms.



Additional Resources

- **Managing Cover Crops Profitably**, SARE Learning Center. <http://www.sare.org/Learning-Center>
- *Cover crops at UGA* - <http://www.SustainAgGA.org>
- UGA Cover Crop Nitrogen Availability Calculator – Contact your county agent for sample collection and submission. <http://aesl.ces.uga.edu/mineralization/>
- OSU Organic Fertilizer and Cover Crop Calculator - <http://smallfarms.oregonstate.edu/calculator>
- Sustainable Practices for Vegetable Production in the South www.cals.ncsu.edu/sustainable/peet/index.html
- National Sustainable Agriculture Information Service (ATTRA) www.attra.org
- Inoculant information <http://cmgm.stanford.edu/~mbarnett/rhiz.htm>



Learning Activity

- Cover Crop Jeopardy





This material is based upon work that is supported by the National Institute of Food and Agriculture, U.S. Department of Agriculture, under award number 2015-70017-22861.


USDA Beginning Farmer and Rancher Development Program



Developing the Next Generation of Sustainable Farmers in Georgia Grant



Cover crop ~Jeopardy~



Summer Cover	Function Junction	Winter Cover	Know the Benefits
<u>10</u>	<u>10</u>	<u>10</u>	<u>10</u>
<u>20</u>	<u>20</u>	<u>20</u>	<u>20</u>
<u>30</u>	<u>30</u>	<u>30</u>	<u>30</u>




Category 1. Question 1.

These plants have a vining growth habit in the summer and are used to supply nitrogen and help suppress weeds.

Question

Category 1 Answer 1

What are cowpeas?



Photo: Lindsay Davies

Category 1 Question 2

These plants grow in the summer and will be killed by frost. They have small flowers and are loved by pollinators and beneficial insects.

Question

Category 1 Answer 2

What is buckwheat?



Photo: Lindsay Davies

Category 1 Question 3

These plants are grown in the summer and may be useful for farmers without heavy equipment because they produce a moderate amount of biomass.

Question

Category 1 Answer 3

What are millets?



Applause



Explosion



Category 2 Answer 1

Legumes have to have a relationship with this in order to fix N.

Question

Category 2 Question 1

What is bacteria?



Photo: Jessica Cudnik

Category 2 Answer 2

This tropical summer legume is a good weed suppressant and fixes a large amount of Nitrogen in a short period of time.

Question

Category 2 Question 2

What is sunnhemp?

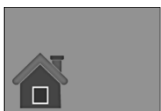


Photo: Lindsay Davies

Category 2 Answer 3

This process causes Nitrogen to be released to the soil for crops to use.

Question

Category 2 Question 3

What is mineralization?



Category 3 Answer 1

These plants are the winter cover crop workhorses. They have a large amount of biomass, help suppress weeds, and are deep rooted so can scavenge nutrients.

Question

Category 3 Question 1

What is cereal rye?



Category 3 Answer 2

These plants are grown in the winter and are known to help suppress nematode populations.

Question

Category 3 Question 2

What are brassica cover crops?



Category 3 Answer 3

These plants are planted each year in the fall and grown over the winter to provide nitrogen for spring cash crops. Their scarlet flowers make beautiful fields before the cover is killed.

Question

Category 3 Question 3

What is crimson clover?



Photo: Julia Gaskin

Category 4 Answer 1

These plants have large tap roots and are thought to help alleviate soil compaction.

Question

Category 4 Question 1

What is tillage radish?



Photo: Jessica Cudnik



Category 4 Answer 2

Cover crop benefits are maximized by treating them like a cash crop and having good seed/soil contact, timely planting and killing them as late as possible. All these practices maximize a key characteristic of the cover crop.

Question

Category 4 Question 2

What is biomass?



Photo: Jessica Cudnik



Category 4 Answer 3

This is a benefit of using a mixture of different cover crops.

Question

Category 4 Question 3

What are diversity and different functions?



Photo: Jessica Cudnik





Small Fruit and Vegetable Production



Session 2 Ground Covers for Small Fruits

David Berle, Associate Professor
Horticulture Department
University of Georgia



Learning Objectives

- Problems of weed management unique to fruit crops
- Alternatives for ground cover in small fruits



Weed management in small fruits

- All fruits, except strawberries are perennials
- Small fruits have shallow roots, like many weeds
- Hard to till or cultivate for weed management
- Weeds build up over time
- Herbicides are available for non-organic production

JOURNEYMAN FARMER
CERTIFICATE PROGRAM

Soil cultivation for weed management

- Cultivation
 - Till area PRIOR to planting
 - Multiple times every few weeks leading up to planting
 - Deep enough to dig weeds, but not too deep
 - Light cultivation once planted, for first year
 - Hand hoeing or tractor cultivator
 - Don't disturb roots

JOURNEYMAN FARMER
CERTIFICATE PROGRAM

Barriers for weed management

- Organic mulches
 - Pine bark and wood chips
 - Wheat straw and pine straw
- Pros
 - Non-chemical option
 - Readily available
- Cons
 - Can be expensive
 - Weeds can grow through mulch layer



Photo credit: Gerald Larsen, Fort Valley State University.

JOURNEYMAN FARMER
CERTIFICATE PROGRAM

Barriers for weed management

- Fabric
 - Pros:
 - Can help reduce weeds, easy to install
 - Cons:
 - Weeds will grow on top of fabric over time
 - Plants that grow by sprouting could be problem
 - Blackberries, raspberries, blueberries
 - Sprouts can't get through
 - Best for apples, grapes, peaches, pears



Photo credit:
<http://regonstate.edu/dept/NWREC/programs/berry-crops>

JOURNEYMAN FARMER
CERTIFICATE PROGRAM

Living ground cover for weed management

- Plants as a ground cover
- Subterranean clover for row middles
 - Non-competitive cool season legume
 - Tolerates poor soil and drought
 - Easy to manage



Photo credit: Gerald Larsen, Fort Valley State University

JOURNEYMAN FARMER
CERTIFICATE PROGRAM

Additional Resources

- Grow Your Own Small Fruits, Fort Valley State University (<http://www.caes.uga.edu/topics/sustainag/documents/OrganicSmallFruits-brochure.pdf>)
- Grow Your Own Small Fruits (Video), Fort Valley State University (<https://vimeo.com/43920333>)

JOURNEYMAN FARMER
CERTIFICATE PROGRAM

How to Convert an Inorganic Fertilizer Recommendation to an Organic One

*Revised by Julia Gaskin, David Kissel, Glen Harris and George Boyhan
Original manuscript by Wayne McLaurin, retired Horticulture Professor, and
Water Reeves, retired Horticulture Educator*

Successful production of any crop begins with the soil. A fertile, biologically active soil provides plants with most of the nutrients needed for good growth. Fertilizers can supplement or renew these nutrients, but they should be added only when a soil test indicates the levels of available nutrients in the soil are inadequate for proper plant growth and high yields.

Whether you are growing annuals or perennials, vegetables or flowers, most crops have a few short months to grow and develop flowers and fruits. The soil must provide a steady, uninterrupted supply of readily available nutrients for maximum plant growth. Fertilizer form, particle size, solubility, the amount applied and the potential uptake are important factors in providing fertility for successful growth.

Many farmers and gardeners use natural minerals and organic fertilizers rather than synthetic ones to build their soil. If you use organic materials as all or part of your fertilization program, this publication will help you calculate the proper amount to use from the recommendations provided by a soil test.

Certified Organic growers use fertilizers that meet standards in the National List by the USDA National Organic Program (www.ams.usda.gov/nop). The Organic Materials Review Institute (OMRI – www.OMRI.org), a private organization, evaluates and endorses products that meet these standards. If you are a Certified Organic grower, you should always check with your certifier before using new products.

Organic Matter

Organic matter consists of a wide variety of carbon-containing compounds in the soil. It is created from plant debris, roots, microbes and other organisms that live in the soil. Organic matter provides energy and a food source for biological activity. Many nutrients are held in organic matter until soil microorganisms decompose the materials and release them for plant use. This is an important point, because although organic growers add fertilizer in an organic form, the nutrients have to be converted to an inorganic form before they are available for plant use. For example, nitrogen in an organic fertilizer can be in the form of a protein (the organic form) that must be converted to ammonium and/or nitrate before it can be taken up by plants.

Organic matter also helps attract and hold plant nutrients, reducing the amount lost through leaching. It improves the soil structure so that air reaches plant roots and also aids in retaining soil moisture. Because organic matter has such a strong influence on the chemical, biological and physical properties of the soil, building and maintaining soil organic matter is central to organic production.



Georgia soil with high organic matter content.

Fertilizer Labels – What They Mean

Georgia law requires fertilizer producers to display the guaranteed analysis or grade on a label on the fertilizer container. A fertilizer grade or analysis that appears on the bag gives the percentages of nitrogen (N), phosphate (P_2O_5) and potash (K_2O) in the material. A 5-10-15 grade fertilizer contains 5 percent N, 10 percent P_2O_5 and 15 percent K_2O . A 50-pound bag of 5-10-15 fertilizer contains 2.5 pounds of N ($50 \times 0.05 = 2.5$), 5 pounds of P_2O_5 ($50 \times 0.10 = 5$) and 7.5 pounds of K_2O ($50 \times 0.15 = 7.5$).

The fertilizer ratio is the ratio of the percentages of N, P_2O_5 and K_2O in the fertilizer mixture based on the nutrient present in the smallest percentage. Examples of a 1-1-1 ratio fertilizer are 10-10-10 and 8-8-8. These fertilizers have equal amounts of nitrogen, phosphate and potash. An example of a fertilizer with a 1-2-3 ratio is 5-10-15. This fertilizer would have twice as much phosphate and three times as much potash as nitrogen.

Fertilizer Recommendations

Although different crops have different nutrient needs, in general, crops need major nutrients in an approximate ratio of 4-1-2 (N- P_2O_5 - K_2O). Because soils differ in their ability to supply nutrients and because the proportion of N, P_2O_5 and K_2O in any given organic fertilizer does not usually match the proportions a crop needs, it is rare to be able to supply all plant nutrient needs from only one organic material. Consequently, most organic fertilizers are used in combinations. Table 1 lists commonly available organic fertilizers and the usual proportions of N, P_2O_5 and K_2O .

There are no one-size-fits-all fertilizer recommendations. All fertilizer recommendations should take into consideration soil pH, residual nutrients and inherent soil fertility as well as the needs of the crop to be grown. Fertilizer recommendations based on soil analyses are the best chance for getting the right amount of fertilizer without over- or under-fertilizing and result in the most efficient use of lime and fertilizer materials. This efficiency can occur only when valid soil sampling procedures are used to collect the samples submitted for analyses. To be beneficial, a soil sample must reliably represent the field, lawn, garden or “management unit” from which it is taken. Information on how to take a representative soil sample is referenced in the back of this publication. If you have

other questions about soil sampling, contact your local county Extension office for more information.

Soil test results do not include nitrogen because the amount of plant-available nitrogen in soils can change quickly due to unpredictable weather conditions such as heavy rainfall. Consequently, tests of plant-available nitrogen taken weeks ahead of planting are not reliable and do not correlate well with crop yields. Instead, inorganic nitrogen fertilizer recommendations are based on many research trials of crop yield response to nitrogen fertilizer rates. These trials and the resulting recommendations *do not account for nitrogen available from a previous cover crop* because nitrogen from cover crops varies from season to season. Nitrogen fertilizer rates should be reduced by the amount of nitrogen available from a cover crop. This is called nitrogen credit. A quick estimate of nitrogen credits from a cover crop can be made using the calculations found on pages 22-23 of “Managing Cover Crops Profitably” (see Reference section).

pH

An underlying cause of poor fertility in Georgia is acidic soil. Soil pH strongly influences plant growth, nutrient availability and microorganism activity in the soil. It is important to keep soil pH in the proper range to obtain the best yields and high-quality growth. A pH that is too low or too high can cause nutrients to become unavailable to plants.

The best pH range for most plant growth is 6.0 to 7.0. There are some exceptions, including Irish potatoes, blueberries and rhododendrons, which grow well at pHs of approximately 5.5, less than 5.0 and around 5.5, respectively.

Most soils in Georgia are naturally acidic. Limestone that contains calcium and magnesium carbonates, which increase soil pH, must be applied to keep the soil pH in the proper range. A soil test is essential for determining how much limestone should be applied. This type of testing should be conducted at least every two years.

Calcium does not move quickly down through the soil profile. If lime is recommended for vegetable crop production, in most cases, limestone should be broadcast and thoroughly incorporated to a depth of 6 to 8 inches before planting to neutralize the soil acidity in

the root zone. For farmers using no-till, lime can be surface applied regularly to maintain pH. For best results, limestone should be applied two to three months before seeding or transplanting. However, liming can still be beneficial if applied at least one month before seeding or transplanting.

There are two types of limestone. One is composed primarily of calcium materials and is referred to as calcitic limestone. The second, known as dolomitic limestone, contains both calcium and magnesium. Your soil test will indicate which limestone is most suitable for your situation. If plant-available magnesium levels in the soil are low, dolomitic limestone is preferred.

Environmental Effects on Organic Nutrient Uptake

Soil Temperature – Early spring in Georgia is cool and soil temperatures rise slowly to the point where microorganisms are active. Until the soil warms sufficiently and the organic fertilizer materials are broken down into their usable form, these fertilizers may not successfully stimulate plant growth.

Soil Moisture – In addition to warmer temperatures, soil microorganisms need a moist soil to grow and thrive. If rainfall is not adequate, crops may need to be irrigated for good nutrient release.

Calculating Organic Fertilizer Needs

Soil test reports give fertilizer recommendations in three ways. The first, generally used by larger commercial farms, gives the nutrients needed for a particular crop in pounds per acre (lbs/ac). The second, generally used for smaller farms or larger gardens, gives a particular fertilizer grade or combination of grades that should be used per 1,000 square feet (sq. ft.). The third gives fertilizer grades per 100 feet of row. Examples of how to make conversions in each of these cases are included below.

Because a combination of organic fertilizers is usually needed, the conversion process has several steps. In general, start with the most complex organic fertilizer, such as compost and animal manures (e.g., poultry litter). Many organic growers use these as a fertilizer base. These fertilizers will contain amounts of all three major nutrients – N, P and K – as well as micronutrients; however, the amount of nutrients in a given animal manure or compost is variable, so these materials should be analyzed. The amount of moisture in animal manures and composts can greatly affect the amount of nutrients applied. The University of Georgia reports nutrient content based on the moisture in the sample as it was received; consequently, these numbers do not have to be corrected for moisture content.

If you don't have the animal manures and composts tested, approximate values for N, P_2O_5 and K_2O are listed in Table 1. When using these materials as a fertilizer base, calculate how much N, P_2O_5 and K_2O are supplied by these materials, then supplement nutrients from other sources as needed for a particular crop.

See Examples 1-4 on the following pages.

Example 1: Conversion for Farms on an Acre Basis

Farmer Jolene receives a soil test report for Plot 1 that indicates the soil organic matter is 1.5%, the pH is 6.0, the soil test P is medium and the soil test K is low. She will be growing peppers in this section next spring. The soil test fertilizer recommendations call for: 150 lbs/acre of N, 80 lbs/acre of P_2O_5 and 120 lbs/acre of K_2O . She usually applies 1 ton of poultry litter compost (3-4-3) over her 1-acre plot and tills it in to build organic matter.

Step 1. Calculate the amount of nutrients provided by the compost.

$$2,000 \text{ lbs compost (1 ton)} \times 0.03 \text{ (percent N)} = 60 \text{ lbs Total N}$$

- Adjust total N provided by compost for the amount that will be available during that growing season, usually about 10%.

$$60 \text{ lbs Total N} \times 0.1 = 6 \text{ lbs}$$

$$2,000 \text{ lbs compost (1 ton)} \times 0.04 \text{ (percent } P_2O_5) = 80 \text{ lbs } P_2O_5$$

$$2,000 \text{ lbs compost (1 ton)} \times 0.03 \text{ (percent } K_2O) = 60 \text{ lbs } K_2O$$

- Nutrients supplied by compost are: 6 lbs N, 80 lbs P_2O_5 and 60 lbs K_2O

Step 2. Subtract nutrients supplied by the compost from the nutrients needed.

$$150 \text{ lbs N} - 6 \text{ lbs N} = 144 \text{ lbs N}$$

$$80 \text{ lbs } P_2O_5 - 80 \text{ lbs } P_2O_5 = 0 \text{ lbs } P_2O_5$$

$$120 \text{ lbs } K_2O - 60 \text{ lbs } K_2O = 60 \text{ lbs } K_2O$$

- Here, the compost supplies all of the P_2O_5 needed. Additional nutrients needed by plants are 144 lbs N and 60 lbs K_2O .

Step 3. Pick an additional organic fertilizer to supply the rest of the needed nutrients.

The greatest fertilizer need is for N. Consequently, Jolene wants a fertilizer with a fairly high N content that can also supply K_2O . She picks a commercially available OMRI product with an 8-5-5 content. Remember, this will supply 8 lbs of N, 5 lbs of P_2O_5 and 5 lbs of K_2O per 100 lbs of fertilizer.

- Jolene decides to apply enough of this fertilizer to supply the K_2O needs.

$$\begin{aligned} \text{lbs of fertilizer needed} &= 60 \text{ lbs } K_2O / (5 \text{ lbs } K_2O / 100 \text{ lbs fertilizer}) \\ &= 60 \text{ lbs } K_2O / 0.05 \\ &= 1,200 \text{ lbs of fertilizer} \end{aligned}$$

- How much N and P_2O_5 will be added?

$$N: 1,200 \text{ lbs fertilizer} \times (8 \text{ lbs N} / 100 \text{ lbs fertilizer}) = 96 \text{ lbs N}$$

$$P_2O_5: 1,200 \text{ lbs fertilizer} \times (5 \text{ lbs } P_2O_5 / 100 \text{ lbs fertilizer}) = 60 \text{ lbs } P_2O_5$$

Step 4. Subtract the nutrients supplied by the fertilizer to determine if additional N or P_2O_5 are needed.

$$144 \text{ lbs N} - 96 \text{ lbs N} = 48 \text{ lbs N}$$

$$0 \text{ lbs } P_2O_5 - 60 \text{ lbs } P_2O_5 = -60 \text{ lbs } P_2O_5$$

These calculations indicate that much of the N and all of the K_2O needs for the pepper crop can be met by applying the usual 2,000 lbs of compost plus 1,200 lbs of the organic 8-5-5 on Jolene's 1-acre plot. Notice that with this combination of fertilizers, P_2O_5 is **overapplied**. Because Jolene's soil test P is in the medium range and all the compost P may not be immediately available, this is not an immediate problem. But, if she continues to use this combination, she will end up with high levels of phosphorus in her soils. In some cases this can cause environmental problems. For true sustainability, she should try to better match the crop needs with the applied P_2O_5 . By our calculations, Jolene is still 48 lbs of N short. She would need to use an N-only fertilizer like blood meal to make up this difference.

Example 2: Conversion on a 1,000 sq. ft. Basis

This is the same scenario as above with Farmer Jolene, except she is working with a 1,000 sq. ft. plot. She usually puts out 50 lbs of compost as her base soil amendment.

Step 1. Convert the lbs/acre recommendations to lbs/1,000 sq. ft.

$$1 \text{ acre} = 43,560 \text{ sq. ft.}$$

$$1,000 \text{ sq. ft.} / 43,560 \text{ sq. ft.} = 0.023 \text{ acres} / 1000 \text{ sq. ft.}$$

- Multiply the lbs/acre recommendations by 0.023

$$150 \text{ lbs / acre of N} \times 0.023 = 3.5 \text{ lbs N} / 1,000 \text{ sq. ft.}$$

$$80 \text{ lbs / acre } P_2O_5 \times 0.023 = 1.8 \text{ lbs } P_2O_5 / 1,000 \text{ sq. ft.}$$

$$120 \text{ lbs / acre } K_2O \times 0.023 = 2.8 \text{ lbs } K_2O / 1,000 \text{ sq. ft.}$$

Step 2. Calculate the amount of nutrients provided by the compost.

$$50 \text{ lbs compost} \times 0.03 \text{ (percent N)} = 1.5 \text{ lbs Total N}$$

- Because the N is only about 10% available, N would only be about 0.15 lbs in the first growing season.

$$50 \text{ lbs compost} \times 0.04 \text{ (percent } P_2O_5) = 2 \text{ lbs } P_2O_5$$

$$50 \text{ lbs compost} \times 0.03 \text{ (percent } K_2O) = 1.5 \text{ lbs } K_2O$$

- Nutrients supplied by the compost are: 0.15 lbs N, 2 lbs P_2O_5 , and 1.5 lbs K_2O

Step 3. Subtract nutrients supplied by the compost from the nutrients needed.

$$3.5 \text{ lbs N} - 0.15 \text{ lbs N} = 3.4 \text{ lbs N}$$

$$1.8 \text{ lbs } P_2O_5 - 2 \text{ lbs } P_2O_5 = -0.2 \text{ lbs } P_2O_5$$

$$2.8 \text{ lbs } K_2O - 1.5 \text{ lbs } K_2O = 1.3 \text{ lbs } K_2O$$

- Nutrients needed by plants are: 3.4 lbs N, 0 lbs P_2O_5 and 1.3 lbs K_2O per 1,000 sq. ft. The compost application has met the P_2O_5 need, if all the P_2O_5 is available over the growing season.

Step 4. Pick an additional organic fertilizer to supply the rest of the needed nutrients.

Jolene picks a commercially available OMRI product with an 8-5-5 content. Remember, this will supply 8 lbs of N, 5 lbs of P_2O_5 and 5 lbs of K_2O per 100 lbs of fertilizer. Jolene decides to apply enough of this fertilizer to supply the N needs.

$$\text{lbs of fertilizer needed} = 3.5 \text{ lbs N} / (8 \text{ lbs N} / 100 \text{ lbs fertilizer})$$

$$= 3.5 \text{ lbs N} / 0.08$$

$$= 44 \text{ lbs of fertilizer per 1,000 sq. ft.}$$

- How much P_2O_5 and K_2O will be added?

$$P_2O_5: 44 \text{ lbs fertilizer} \times 0.05 = 2.2 \text{ lbs } P_2O_5 \text{ per 1,000 sq. ft.}$$

$$K_2O: 44 \text{ lbs fertilizer} \times 0.05 = 2.2 \text{ lbs } K_2O \text{ per 1,000 sq. ft.}$$

Step 5. Subtract nutrients supplied by the fertilizer to determine if additional P_2O_5 or K_2O are needed.

$$-0.2 \text{ lbs } P_2O_5 - 2.2 \text{ lbs } P_2O_5 = -2.4 \text{ lbs } P_2O_5$$

$$1.3 \text{ lbs } K_2O - 2.2 \text{ lbs } K_2O = -0.9 \text{ lbs } K_2O$$

In this case, Farmer Jolene is overapplying both P_2O_5 and K_2O . Because her soil test P_2O_5 is medium and K_2O is low, the overapplication will not be detrimental at this point. The overapplication of K_2O will help build the soil test K into a medium or high range.

Examples 1 and 2 describe a method to balance a crop's nutrient needs with fertilizers and compost. This method will help prevent nutrient imbalances in the soil. You may need to try several different combinations of fertilizers or amendments to find the best combination. You should also compare costs of various combinations.

Another way of converting the inorganic fertilizer recommendations to organic ones is to look for organic fertilizer that contributes most of one nutrient. You can then calculate the amount of each fertilizer you need to meet the crop's needs. Example 3 shows you how to use this approach.

Example 3: Working with Fertilizer Grades on 1,000 sq. ft. Basis

Gardener Joe has received his soil test report for his 1,000-sq.-ft. garden. The soil test report indicates the pH is 5.5 and recommends 20 lbs of lime to correct the soil pH. It also recommends 20 lbs of 5-10-15 plus 1 lb of 34-0-0 per 1,000 sq. ft.

Step 1. Calculate the nitrogen (N) recommendation.

- Use a high N source of fertilizer such as blood meal (12-1.5-0.6). Divide the nitrogen number of the inorganic source (5 in the 5-10-15) by the nitrogen number of the blood meal (12 in the 12-1.5-0.6). Multiply this answer by the lbs of inorganic fertilizer recommended.

$$5 \div 12 = 0.42$$
$$0.42 \times 20 \text{ lbs.} = 8.3 \text{ lbs. of blood meal per 1,000 sq. ft.}$$

- For the 1.0 lb of ammonium nitrate (34-0-0) called for using blood meal, calculate:

$$34 \div 12 = 2.8 \times 1.0 \text{ lb.} = 2.8 \text{ lbs of blood meal per 1,000 sq. ft.}$$

Total organic nitrogen = 11 lbs of blood meal
(8.3 lbs + 2.8 lbs)

The amount of P_2O_5 and K_2O can be calculated the same way. The 0.17 lbs of P_2O_5 and 0.07 lbs of K_2O in the blood meal are not significant enough to be counted.

Step 2. Calculate the phosphorus (P_2O_5) recommendation.

- Use steamed bone meal (approximately 1-11-0) for the phosphorus source. Divide the P_2O_5 (10) by the organic P_2O_5 number (11) to get 0.91. Multiply 0.91 by the 20 lbs needed for a total of 18.2 lbs of steamed bone meal required for 1,000 sq. ft.

$$\text{Total organic phosphorus} = 10 \div 11 = 0.91 \times 20 \text{ lbs} = 18.2 \text{ lbs of steamed bone meal per 1,000 sq. ft.}$$

Because bone meal contains 1% N, you will also be adding 0.18 lbs of N, but this is not significant enough to be counted.

Step 3. Calculate the potassium (K_2O) recommendation.

- Sulfate of Potash Magnesia (0-0-22) is a mined material that can be used for the K_2O requirements. Dividing the K_2O number recommended (15) by the K_2O number of the Sulfate of Potash Magnesia (22) equals 0.682. Multiplying 0.682 by 20 lbs of fertilizer needed results in 13.6 lbs of Sul-Po-Mag per 1,000 sq. ft.

$$K_2O = 15 \div 22 = 0.682 \times 20 \text{ lbs} = 13.6 \text{ lbs of Sulfate of Potash Magnesia per 1,000 sq. ft.}$$

These calculations indicate Farmer Joe can meet his garden's nutrient needs by applying 11 lbs of blood meal, 18.2 lbs of steamed bone meal and 13.6 lbs of Sulfate of Potash Magnesia.

Example 4: Organic Fertilizer for 100 Feet of Row

Farmer Jack's soil test results recommend 7 lbs of 5-10-15 plus 0.5 lbs of ammonium nitrate per 100 linear feet of garden row.

Step 1. Calculate the nitrogen recommendation.

- Using poultry litter (4-4-3) for the nitrogen source of fertilizer, divide the nitrogen number of the inorganic source (5) by the nitrogen number of the poultry litter (4). Multiply this answer by the lbs of inorganic fertilizer recommended.

$$5 \div 4 = 1.3 \times 7 \text{ lbs} = 8.8 \text{ lbs total N of poultry litter per 100 linear feet of row}$$

- For the 0.5 lbs of ammonium nitrate called for using poultry litter, calculate:

$$34 \div 4 = 8.5 \times 0.5 \text{ lbs} = 4.3 \text{ lbs total N from poultry litter}$$

- By these calculations, Farmer Jack should apply 13 lbs of poultry litter per 100 linear feet of row to meet his N fertilizer needs.

$$(8.8 + 4.3 \text{ lbs} = 13.1 \text{ lbs of poultry litter})$$

- Remember:** With animal manure, not all of the total N will be available. UGA Cooperative Extension estimates only 65% of the N in poultry litter that has been incorporated in the soil is available for plant use. Consequently, adjust the amount to be applied to ensure the crops get sufficient N.

$$13 \text{ lbs total N} \div 0.65 = 20 \text{ lbs of poultry litter}$$

This amount should be applied to meet the N needs.

Step 2. Calculate P_2O_5 and K_2O supplied by the poultry litter.

$$P_2O_5: 20 \text{ lbs of poultry litter} \times 0.04 = 0.8 \text{ lbs } P_2O_5$$

$$K_2O: 20 \text{ lbs of poultry litter} \times 0.03 = 0.6 \text{ lbs } K_2O$$

Step 3. Calculate the phosphorus recommendation.

- The fertilizer recommendation is 7 lbs of 5-10-15. Calculate the amount of P_2O_5 needed by multiplying 7 lbs by the P_2O_5 proportion in the fertilizer ($10 \div 100 = 0.1$).

$$7 \text{ lbs} \times 0.1 = 0.7 \text{ lbs } P_2O_5$$

- Compare this number (0.7 lbs P_2O_5) with the amount of P_2O_5 applied with the poultry litter (0.8 lbs P_2O_5). In this case, the poultry litter supplies sufficient P_2O_5 .

Step 4. Calculate the potassium recommendation.

- The fertilizer recommendation is 7 lbs of 5-10-15. Calculate the amount of K_2O needed by multiplying 7 lbs by the K_2O proportion in the fertilizer ($15 \div 100 = 0.15$).

$$7 \text{ lbs} \times 0.15 = 1.1 \text{ lbs } K_2O$$

- Compare this number (1.1) with the amount of K_2O applied with the poultry litter (0.6).

$$1.1 - 0.6 = 0.5 \text{ lbs } K_2O \text{ per 100 ft. of row}$$

Farmer Jack needs to apply an additional 0.5 lbs K_2O per 100 ft. of row. He can use Sulfate of potash Magnesia, as in Example 2.

NOTE – Wood ash has long been used as a source of K_2O ; however, it should be used sparingly. Overapplication can raise the pH above the recommended range for crops and can create problems due to high salt concentrations. If you use wood ash, it is recommended that no more than 10 to 12 lbs be used per 1,000 sq. ft. per year, or about 1 lb per 100 ft. of row. An analysis of the wood ash will help you know how much to apply.

Summary

These examples can help you convert inorganic fertilizer recommendations to organic ones. If you need further help, your local county agent is a good resource. How you use these inorganic fertilizer recommendations may depend on whether the field is in a soil building or soil maintenance stage. New and transitioning growers often have fields that need more soil organic matter and available nutrients because the soils are moving to a new biological and chemical equilibrium. If you are in a soil building stage, following the fertilizer recommendations will help you improve your soil fertility and quality.

Fields are likely in the soil building stage if:

- soil organic matter is below 1.5% in the Coastal Plain or 2.5% above the fall line, and/or
- soil test indices for P, K and other nutrients are in the low or medium range.

Many organic growers reduce fertilizer use by 10 to 20% in the soil maintenance stage. The percent reduction depends on site-specific conditions such as the amount of soil organic matter buildup and nutrients available as well as yield goals.

References and Further Information

Soil Testing for Home Lawns, Gardens and Wildlife Food Plots. University of Georgia Cooperative Extension Circular 896. http://www.caes.uga.edu/Publications/pubDetail.cfm?pk_id=7440

Managing Cover Crops Profitably. <http://www.sare.org/Learning-Center/Books/Managing-Cover-Crops-Profitably-3rd-Edition>

Manures for Organic Crop Production (ATTRA) <https://attra.ncat.org/attra-pub/manures.html#fieldapp>

Organic Fertilizer Calculator (Oregon State University) http://smallfarms.oregonstate.edu/sites/default/files/em8936-e_med_res_0.pdf

Table 1. Guide to the mineral nutrient value of organic fertilizers.

All values are percent on an as-is basis unless otherwise noted.

These percentages can be highly variable and should be used as an estimate.

Materials	N	P ₂ O ₅ ¹	K ₂ O	Relative Availability ¹
Alfalfa Meal	3.0	1.0	2.0	Medium-Slow
Blood Meal	12.0	1.5	0.6	Medium-Rapid
Bone Meal (steamed) ²	0.7-4.0	11.0-34.0	0.0	Slow-Medium
Brewers Grain (wet)	0.9	0.5	0.1	Slow
Castor Pomace	5.0	1.8	1.0	Slow
Cocoa Shell Meal	2.5	1.0	2.5	Slow
Coffee Grounds (dry)	2.0	0.4	0.7	Slow
Colloidal Phosphate	0.0	18.0-24.0	0.0	Slow
Compost (not fortified) ³	1.5	1.0	1.5	Slow
Corn Gluten Meal	9.0	0.0	0.0	Medium
Cotton Gin Trash	0.7	0.2	1.2	Slow
Cottonseed Meal (dry)	6.0	2.5	1.7	Slow-Medium
Eggshells	1.2	0.4	0.1	Slow
Feather meal	11.0-15.0	0.0	0.0	Slow
Fish Meal	10.0	4.0	0.0	Slow-Medium
Fish Emulsion	5.0	2.0	2.0	Medium-Rapid
Fish Powder (dry) ⁴	12.0	0.25	1.0	Rapid
Grape Pomace	3.0	0.0	0.0	Slow
Granite Dust	0.0	0.0	6.0	Very Slow
Greensand	0.0	1.0-2.0	5.0	Slow
Guano (bat)	5.7	8.6	2.0	Medium
Guano (Peru)	12.5	11.2	2.4	Medium
Hoof/Horn Meal	12.0	2.0	0.0	Medium-Slow
Kelp ⁵	0.9	0.5	1.0	Slow
Manure ⁶ (fresh or as is)				
Broiler Litter	3.1	3.1	2.8	Medium-Rapid
Cattle	0.5	0.2	0.4	Medium
Horse	0.6	0.3	0.6	Medium
Sheep/Goat	0.6	0.33	0.75	Medium
Swine	0.6	0.2	0.4	Medium
Manure ⁶ (dry)				
Cricket	3.0	2.0	1.0	Medium-Rapid
Dairy	0.5	0.2	0.5	Medium
Rabbit	2.0	1.3	1.2	Medium
Marl	0.0	2.0	4.5	Very Slow
Mushroom Compost	0.7	0.9	0.6	Slow-Medium
Sulfate of Potash Magnesia ⁷	0.0	0.0	22.0	Rapid
Soybean Meal	6.7	1.6	2.3	Medium-Slow
Wood Ashes ⁸	0.0	1.0-2.0	3.0-7.0	Rapid

¹Rapid = < 1month; Medium = 1 to 4 months; Slow = 4 months to 1 year; Very Slow = > 1 year.²Research at Colorado State University indicates bone meal phosphorus is only available at soil pHs below 7.0.³Nutrient content varies considerably with feedstock used for compost.⁴Usually dissolved in water.⁵Primarily a micronutrient source.⁶Plant nutrients available during year of application vary with amount of straw/bedding and storage method.⁷Also known as Sul-Po-Mag, K-Mag or Langbeinite. For Certified Organic use must not be acid treated.⁸Potash content depends on the tree species burned. Wood ashes are alkaline, containing approximately 32% CaO.

For those who do not want to figure out the equivalent weights, here is an approximation of amounts of ingredients to use to attain the correct amounts of organic fertilizers called for in the soil test for 1,000 sq. ft. You should not rely on these approximations without doing soil testing to confirm nutrient needs.

Table 2. Organic fertilizer recommendations based on average nutrient contents for the various materials.

Recommendations for Inorganic Fertilizers	Nitrogen¹ Needed for 5 lbs of 5-10-15 from Organic Source	Phosphorus Needed for 5 lbs of 5-10-15 from Organic Source	Potassium Needed for 5 lbs of 5-10-15 from Organic Source
5 lbs 5-10-15 (using component fertilizers)	2.0 lbs blood meal 8.3 lbs alfalfa meal 4.2 lbs cotton seed meal 2.0 lbs feather meal 2.5 lbs fish meal 2.0 lbs hoof meal 8.0 lbs cricket manure 4.0 lbs soybean meal	4.5 lbs bone meal 1.4 lbs colloidal phosphate	3.1 lbs Sul-Po-Mag 15.0 lbs greensand 15.0 lbs granite dust 25.0 lbs kelp
	Nitrogen Needed for 5 lbs of 6-12-12	Phosphorus Needed for 5 lbs of 6-12-12	Potassium Needed for 5 lbs of 6-12-12
5 lbs 6-12-12 (using component fertilizers)	2.0 lbs blood meal 10.0 lbs alfalfa meal 5.0 lbs cotton seed meal 2.0 lbs feather meal 2.5 lbs fish meal 2.5 lbs hoof meal 10.0 lbs cricket manure 3.7 lbs soybean meal	5.5 lbs bone meal 3.0 lbs colloidal phosphate	2.7 lbs Sul-Po-Mag 12.0 lbs greensand 12.0 lbs. granite dust 20.0 lbs kelp
Nitrogen, Phosphorus and Potassium Needed for 5 lbs of 10-10-10			
5 lbs 10-10-10 (for even analysis fertilizers)	33.3 lbs of compost (1.5-1-1.5) 33.0 lbs of 30% poultry manure (3-2.5-1.5) 50.0 lbs of OMRI approved fertilizer 1-1-1		
	Nitrogen Needed for 5 lbs of 10-10-10	Phosphorus Needed for 5 lbs of 10-10-10	Potassium Needed for 5 lbs of 10-10-10
5 lbs 10-10-10 (using component fertilizers)	4.2 lbs blood meal 17.0 lbs alfalfa meal 8.3 lbs cotton seed meal 3.3 lbs feather meal 5.0 lbs fish meal 4.2 lbs hoof meal 16.7 lbs cricket manure 7.5 lbs soybean meal	4.5 lbs bone meal 2.8 lbs colloidal phosphate	2.3 lbs Sul-Po-Mag 10.0 lbs greensand 16.6 lbs kelp
¹ Use only one of these amounts of fertilizer materials to equal 5 lbs of nitrogen or use one-half of two different materials to make up the 5 lbs of nitrogen required. The same process can be used for any other nutrient in the chart.			

Session 2: Resource Page

Soil Amendments

How to Convert an Inorganic Fertilizer Recommendation to an Organic One

<http://extension.uga.edu/publications/detail.cfm?number=C853>

UGA Extension Publication C 853

Cover Crops

Cover crops at UGA

<http://www.SustainAgGA.org>

UGA Cover Crop Nitrogen Availability Calculator

<http://aesl.ces.uga.edu/mineralization/>

Contact your county agent for sample collection and submission.

Managing Cover Crops Profitably

<http://www.sare.org/Learning-Center>

SARE Learning Center Free pdf online or book for purchase

OSU Organic Fertilizer and Cover Crop Calculator

<http://smallfarms.oregonstate.edu/calculator>

Sustainable Practices for Vegetable Production in the South

www.cals.ncsu.edu/sustainable/peet/index.html

National Sustainable Agriculture Information Service (ATTRA)

www.attra.org

Inoculant information

<http://cmgm.stanford.edu/~mbarnett/rhiz.htm>

Ground Covers for Small Fruits

Grow Your Own Small Fruits

<http://www.caes.uga.edu/topics/sustainag/documents/OrganicSmallFruits-brochure.pdf>

Fort Valley State University

Grow Your Own Small Fruits (Video)

<https://vimeo.com/43920333>

Fort Valley State University

NOTES:



Small Fruit and Vegetable Production

Crop Rotation;

Pest Management; Pesticide Safety

Session Three

Facilitator Notebook

Session 3 - Crop Rotation, Pest Management, Pesticide Safety Facilitator Agenda

Homework Discussion (10 min)

Groundcovers for Small Fruits. Take just 10 minutes to see who watched this webinar and answer a question or two.

Crop Rotation (12 min – David Berle, Horticulture Dept., University of Georgia)

- Principles and benefits of crop rotation

Learning Objectives:

- Recognize characteristics of a good crop rotation program

Pest Management (40 min – David Berle, Horticulture Dept., University of Georgia)

- Pest management strategy– identify, ecology, impact, management, and documentation
- Insect Ecology and Management
 - Insect management strategies – scouting, crop rotation, trap cropping, cultivation, encouraging beneficials and natural predators;
 - Examples of 5-step strategy giving resources for id, life cycles, etc.
- Diseases Ecology and Management
 - Disease triangle;
 - Disease management strategies – resistant varieties, crop rotation, sanitation, managing water, air movement;
 - Examples of 5-step strategy giving resources for id, life cycles, etc.
- Weeds Ecology and Management
 - Annuals vs. perennials;
 - Weed management strategies – depleting seed bank, cultivation, mulch, cover cropping, crop rotation, herbicides;
 - Examples of 5-step strategy giving resources for id, life cycles, etc.

Learning Objectives:

- Name the 5-part strategy of sustainable pest management
- List three sustainable weed management practices
- List three sustainable insect management practices
- List three sustainable disease management practices

Learning Activity (45 min) – Applying Pest Management Strategy Worksheet

For this exercise, you will need access to the internet and be able to project the internet resources onto the large screen in the room.

The websites/handouts you will be referencing are below. They are included in the notebooks and copies are available on the Urban Ag page for you to pull up on the screen if needed.

1. Bugwood Network—<http://www.bugwood.org/>

2. 2015 Southeastern Vegetable Crop Handbook (Please note to participants that this notebook is updated yearly, but for this exercise we will be referring to the 2015 edition. They should use the most recent one when they are using it as a reference.)
 - Table 2-29-Alternative and Biorational Insecticides for Insect Pest Control Strategies in Vegetable Crops
 - Table 2-25 Relative Effectiveness of Insecticides and Miticides for Insect and Mite Control on Field-Grown Vegetables
 - Pages 86-87
 3. Featured Creatures-Squash bug fact sheet
- Work through the worksheet with the participants on the following page.

Homework Assignment – Ask the class to watch the **Pesticide Safety (10 min, David Berle, Horticulture Department, University of Georgia)** webinar (<https://vimeo.com/155724599>) and bring in a seed packet for the next session discussion on germination, propagation and how many seeds and transplants to order. The webinar link is on their agenda.

Session 3

Applying Pest Management Strategy – Learning Activity

(Directions to Facilitators are in Italics, Directions to Participants are in Bold)

Work through the pest problem using the 5-step strategy of pest management.

Step 1: Identify this pest using Bugwood IPM Images.

Go to the Bugwood Network Website. Show them this is a good resource for a lot of pest and invasive species information. Click on the IPM Images located in gray box on right side of the site. Point out the range of crops and topics that they have images for. Click on Vegetables. Click on Beans and show them the images that can help them id pests. Then begin to id the insects in the picture on their worksheet. Ask the group to pick a crop they want to look up on the Bugwood IPM site based on the picture and insect pest below. Go through the images under the crop they select looking for a match. Use the hint if needed – the leaf is from a plant in the curcubit family.

Answer: Squash Bug nymphs



Step 2: Understand ecology of pest

Find pictures on Bugwood that show the other life cycle stages of this pest.

Eggs

Nymphs

Adults

*Find pictures on Bugwood that show the other life cycle stages of this pest by searching for squash bug in the Search box at the upper right corner. Pause at the picture of eggs. Ask them to jot down a couple of words to describe the eggs appearance. Pause at the picture of the nymphs again and ask them to do the same. Do the same things with the adults. We are not going for scientific descriptions here, just teaching them to **look** for details that will help them identify things by image.*

Examples:

Eggs – reddish small, smooth ovals, underside of leaf

Nymphs – black legs, white to grey bodies, soft body when young progressing to look more like adults

Adults – brown to gray, flattish body, small head

Use the Created Features Handout, Table 2-29 of the Southeastern Vegetable Crop Handbook to identify the systems-based practices, mechanical and physical tactics, and natural enemies for pest prevention.

Have the class turn to the Featured Creatures Handout in their notebooks, it is located after the power points in Section 3. Next pull up the pdf of the Southeastern Vegetable Handbook. Point out this is a free download and a good source of growing information. Use Control F to bring up Table 2-29 and lead them through this table to give an example of the resources available in this handbook. Ask the group to identify Systems-based practices, Mechanical & Physical Controls, and Natural Enemies for control using the Table 2-29 and Featured Creatures Handout information. Lead a brief discussion on these practices.

System based practice examples: Trap cropping with Hubbard squash, Plant tolerant varieties, sanitation

Mechanical and Physical examples: Insect netting

Natural Enemy examples: Wasp egg parasitoids, fly parasitoid

Point out Table 2-25 and 2-29 in their notebooks rates chemical controls that are effective. Stress reading labels to make sure they can be used. Have them find a few insecticides and biorationals that are effective for squash bug control.

Venom/Scorpion is very effective. Also Pyrethrin is an effective biorational.

Step 3: Determine impact of pest

Growing squash is popular in Georgia. Use page 85-87 of the Southeastern Vegetable Crop Handbook to briefly scan the most prevalent insect pests that affect squash.

Use the information to determine when you should begin scouting and when you should treat.

Ask the group to find the summer squash growing information in their notebooks. Use Control F and search for squash to quickly find pages 85-87 of the Southeastern Vegetable Crop Handbook to briefly scan the most prevalent insects and their control for squash.

Most prevalent insects: Cucumber beetle, Squash vine borer, Aphids, Squash bugs, Spider mites

When to begin scouting: Shortly after plant emergence. Treat every 7-10 days when adults or nymphs appear.

Step 4 and 5: Select strategy that is least expensive and least harmful to the farm environment. Now that you've identified the pest and researched it for a particular crop. Outline your strategy for managing the pest you identified.

Biological Control	Examples: Parasitoids
Chemical Control	Examples: Venom/Scorpion, Pyrethrin
Cultural Control	Examples: Field sanitation, resistant varieties, timing of planting, crop rotations, trap crop
Physical Control	Examples: insect netting, row covers, hand-picking

Which management practice for this pest would you use first on your farm? Rank the management practices from first to last.

1. *Cultural*
2. *Physical*
3. *Biological*
4. *Chemical*

Homework Assignment: Ask the class to watch the Pesticide Safety (10 min-David Berle, Horticulture Dept, University of Georgia) webinar (<http://vimeo.com/155724599>) and bring in a seed packet for the next session discussion on germination, propagation and how many seeds and transplants to order. The webinar link is in their agenda.

Featured Creatures UF/IFAS Entomology & Nematology Department

common name: squash bug

scientific name: *Anasa tristis* (DeGeer) (Insecta: Hemiptera: Coreidae)

Introduction

The squash bug, *Anasa tristis* (DeGeer), attacks cucurbits (squash and relatives) throughout Central America, the United States, and southern Canada. Several related species in the same genus coexist with squash bug over most of its range, feeding on the same plants but causing much less injury.

Description and Life Cycle

The complete life cycle of the squash bug commonly requires six to eight weeks. Squash bugs have one generation per year in northern climates and two to three generations per year in warmer regions. In intermediate latitudes the early-emerging adults from the first generation produce a second generation whereas the late-emerging adults go into diapause. Both sexes overwinter as adults. The preferred overwintering site seems to be in cucurbit fields under crop debris, clods of soil, or stones but sometimes adults also are found in adjacent wood piles or buildings.

Egg: Eggs are deposited on the lower surface of leaves, though occasionally they occur on the upper surface or on leaf petioles. The elliptical egg is somewhat flattened and bronze in color. The average egg length is about 1.5 mm and the width about 1.1 mm. Females deposit about 20 eggs in each egg cluster. Eggs may be tightly clustered or spread a considerable distance apart, but an equidistant spacing arrangement is commonly observed. Duration of the egg stage is about seven to nine days.

Nymph: There are five nymphal instars. The nymphal stage requires about 33 days for complete development. The nymph is about 2.5 mm in length when it hatches, and light green in color. The second instar is initially about 3 mm long, and its color is light gray. The third, fourth, and fifth instars initially are about 4, 6 to 7, and 9 to 10 mm in length, respectively, and darker gray. The youngest nymphs are rather hairy, but this decreases with each subsequent molt. In contrast, the thorax and wing pads are barely noticeable at hatch, but get more pronounced with each molt. Young nymphs are strongly gregarious, a behavior that dissipates slightly as the nymphs mature.

Adult: The adult measures 1.4 to 1.6 cm in length and is dark grayish brown in color. In many cases the edge of the abdomen is marked with alternating gold and brown spots. Adults are long-lived, surviving an average of about 75 to 130 days, depending on availability and quality of food.



Figure 1. Cluster of squash bug eggs, *Anasa tristis* (DeGeer). Photograph by John L. Capinera.



Figure 2. Adult (bottom) and nymph (top) of the squash bug, *Anasa tristis* (DeGeer). Photograph by John L. Capinera.

Host Plants

The squash bug has been reported to attack nearly all cucurbits, but squash and pumpkin are preferred for oviposition and support high rates of reproduction and survival. There is considerable variation among species and cultivars of squash with respect to susceptibility to damage and ability to support growth of squash bugs. New World varieties are preferred. Studies conducted in the United States reported survival of squash bug to be 70, 49, 14, 0.3, and 0% when nymphs were reared to the adult stage on pumpkin, squash, watermelon, cucumber, and muskmelon (cantaloupe), respectively.

Damage

The squash bug causes severe damage to cucurbits because it secretes highly toxic saliva into the plant. The foliage is the primary site of feeding but the fruit is also fed upon. The foliage wilts, becomes blackened, and dies following feeding; this malady is sometimes called "anasa wilt." Often an entire plant or section of plant perishes while nearby plants remain healthy. The amount of damage occurring on a plant is directly proportional to the density of squash bugs.



Figure 3. Discoloration and death of leaf tissue following feeding by squash bugs, *Anasa tristis* (DeGeer). Photograph by [John Capinera](#), University of Florida.

Since November 2000, scientists have acquired conclusive evidence that the squash bug can act as a vector of the cucurbit yellow vine disease (CYVD) bacterium that kills the plants (Arnold 2001).

Natural Enemies

Several natural enemies of squash bug are known, principally wasp egg parasitoids (Hymenoptera: Encyrtidae and Scelionidae). Up to 30% parasitism among eggs collected in Florida, USA has been reported. Cannibalism among nymphs is common, but this mortality factor has never been quantified. The bugs emit a strong odor when crushed, a fact that may account for low levels of predation. The best known natural enemy is a common parasitoid of several hemipterans, *Trichopoda pennipes* (Fabricius) (Diptera: Tachinidae). The brightly colored adult fly is easy to recognize, having a gold and black thorax and an orange abdomen, with a prominent fringe of feather-like hairs on the outer side of the hind tibia. Flies develop principally in the adult bug, initially castrating the female, and then killing her when the fly emerges. In Connecticut, USA about 20% of the squash bugs have been found to be parasitized in late summer.

Management

Squash bug adults are unusually difficult to kill with insecticides. Although adult control can be accomplished if the correct material is selected, it is advisable to target the more susceptible nymphs. Squash bugs are not often considered a severe pest of large-scale cucurbit production, probably due to the absence of suitable overwintering sites in well managed crop fields and because the bug's effects are diluted by the vast acreage. Small fields and home gardens are commonly damaged, however pollinators, particularly honeybees, are very important in cucurbit production, and insecticide application can interfere with pollination by killing honeybees. If insecticides are to be applied when blossoms are present, it is advisable to use insecticides with little residual activity, and to apply insecticides late in the day, when honeybee activity is minimal.

Adult squash bugs preferentially colonize larger, more mature plants. Thus, early-planted crops may be especially prone to attack. Numbers are also highest on plants during bloom and fruit set. Use of early-planted crops as a trap crop has been proposed, but due to the high value of early season fruit most growers try to get their main crop to mature as early as possible. The use of squash or pumpkin as a trap crop to protect less preferred host plants such as melons and cucumbers is reported to be effective.

The tendency of squash bugs to aggregate in sheltered locations can be used to advantage by home gardeners. Placement of boards, large cabbage leaves, or other shelter for squash bugs induces the bugs to congregate there during the day where they are easily found and crushed. Row covers and netting delay colonization of squash, but bugs quickly invade protected plantings when covers are removed to allow pollination. Removal of crop debris in a timely

manner is very important. Squash bugs will often be found feeding on old fruit or in abandoned plantings, so clean cultivation is essential to reduce the overwintering population. For registered chemical controls see:

[Insect Management Guide for cucurbits](#)

Selected References

- Arnold J. (20 September 2001). Scientists identify insect that transmits CYVD. ARS News Service, *Agricultural Research Service*, USDA.
<http://www.ars.usda.gov/is/pr/2001/010920.htm> (21 November 2001).
- Beard RL. 1940. The biology of *Anasa tristis* DeGeer with particular reference to the tachinid parasite, *Trichopoda pennipes* Fabr. Connecticut Agricultural Experiment Station Bulletin 440:597-679.
- Bonjour EL, Fargo WS. 1989. Host effects on the survival and development of *Anasa tristis* (Heteroptera: Coreidae). *Environmental Entomology* 18:1083-1085.
- Bonjour EL, Fargo WS, Rensner PE. 1990. Ovipositional preference of squash bugs (Heteroptera: Coreidae) among cucurbits in Oklahoma. *Journal of Economic Entomology* 83:943-947.
- Bonjour EL, Fargo WS, Al-Obaidi AA, Payton ME. 1993. Host effects on reproduction and adult longevity of squash bugs (Heteroptera: Coreidae). *Environmental Entomology* 22:1344-1348.

TABLE 2-29. ALTERNATIVE & BIORATIONAL INSECTICIDES FOR INSECT PEST CONTROL STRATEGIES IN VEGETABLE CROPS.

NOTE: Results of many specific control tactics listed below are highly variable. Many have not been tested thoroughly in commercial vegetable systems.

Target Pest	Cropping System	Systems-based Practices (for pest prevention)	Mechanical & Physical tactics (for pest prevention)	Biorational Insecticides (before pests reach outbreak status)	Natural Enemies (NE) [†]
Aphid	Multiple crops	Timely planting and harvest. Reduce water stress; trap crop of okra, sorghum, etc.; removal of alternative hosts	Use of reflective mulches to protect transplants or use row covers after transplanting; use water jet or frequent irrigation to dislodge aphids & reduce plant stress	Insecticidal soap & oil, neem, Pyrethrin, <i>Chromobacterium</i> (Grandevo), Azera (insecticide premix)	Lady beetles, Lacewings [†] , Midges, Parasitic wasps [†] , Predatory stink bugs, Syrphid fly larvae [†]
Asparagus beetle	Asparagus	Use some portion of field as trap crops; use insecticides on trap crops (repeated sprays)	Manually remove beetles from trap crops	Pyrethrin, Spinosad, <i>Chromobacterium</i> (Grandevo)	Lady beetles, Eulophid wasps
Bean leaf beetle	Snap, lima, pole beans	Sanitation (removal of crop debris), site selection (away from wooded areas), delayed planting date.	Hand-pick beetles off the leaves	Insecticidal soap, Pyrethrin, Neem	Tiphidae (parasitoids)
Beet armyworm	Multiple crops	Timely harvest	Destroy egg masses and caterpillars	<i>Bacillus thuringiensis</i> (Xentari, Dipel), Spinosad, <i>Chromobacterium</i> (Grandevo), viruses (Spod-X)	Lady beetles, Lacewing larvae, Soldier bugs
Blister beetle	Multiple crops	—	Hand-picking, insect netting	Spinosad	—
Cabbage looper	Multiple crops	—	Sanitation (remove crop debris). Remove alternate host plants (wild mustard, shepherd's purse)	<i>Bacillus thuringiensis kurstaki</i> , Insecticidal soap & oil, Spinosad, Neem, <i>Chromobacterium</i> (Grandevo)	Trichogramma, Encyrtid & Pteromalid parasitoids, Lacewings
Colorado potato beetle	Multiple crops	Crop rotation, tolerant varieties	Hand-picking	Insecticidal soap, Neem, Pyrethrin (use for larval control)	Lacewing, Ichneumonid wasp
Corn earworm/ Tomato fruitworm	Multiple crops	—	Hand-picking	<i>Bacillus thuringiensis</i> , Insecticidal soap & oil, spinosad, Neem, <i>Chromobacterium</i> (Grandevo)	Flower bugs, Lacewings, Ichneumonid and Pteromalid parasitoids
Cowpea curculio	Snap, lima, pole beans	Crop rotation, sanitation	Timely or early harvest of crop	Insecticidal soap & oil, Pyrethrin, Neem (adults are difficult to kill)	Soldier beetle, Braconid wasps
Cucumber beetle	Multiple crops	Trap crop of Hubbard squash	Insect netting to block beetles (early season protection)	Pyrethrin, neem, parasitic nematodes (weekly soil drench)	Braconid wasps
Cutworm	Multiple crops	Vigorously growing plant varieties; timely planting	Plant collars, floating row covers.	<i>Bacillus thuringiensis</i> (Xentari, Dipel) directed spray to plant base. Spinosad foliar and stem spray; Seduce(spinosad) bait	Lady beetle, Ground beetles
Diamondback moth & Imported cabbageworm	Collard & Mustard greens	Use pheromone traps to monitor moths	Destroy caterpillar clusters on leaves; pheromone mating disruption	<i>Bacillus thuringiensis kurstaki</i> , insecticidal soap, Neem, Pyrethrin, <i>Chromobacterium</i> (Grandevo), Azera (insecticide premix)	<i>Trichogramma brassicae</i> Parasitic wasp [†] , <i>Macrolophus caliginosus</i> (Predatory beetle [†])
European corn borer	Multiple crops	Use tolerant cultivars when possible	Remove caterpillars on foliage	<i>Bacillus thuringiensis kurstaki</i> , insecticidal soap, Neem, Pyrethrin, <i>Chromobacterium</i> (Grandevo)	<i>Trichogramma</i> wasps encourage native Parasitic flies and Wasps
Flea beetle	Multiple crops	Timely planting of crops, trap crops	Use row covers to protect transplants	Insecticidal oil, Neem, Spinosad, Parasitic nematodes (drench in soil), Azera (insecticide premix)	Braconid wasps
Grasshopper	Multiple crops	Maintain a grassy patch away from main crop and use insecticidal bait	Hand-picking, sweep netting	Pyrethrin (multiple applications), Nolo Bait (<i>Nosema locustae</i>)	Nematode bait (Sema-spore)
Hornworm	Tomato	—	Hand-picking	Spinosad, <i>Bacillus thuringiensis kurstaki</i> , Pyrethrin, Neem, <i>Chromobacterium</i> (Grandevo)	Lacewings, Lady beetles, Trichogramma and Braconid wasps
Japanese beetle	Multiple crops	Timely harvest; trap crops to deter feeding on main crop	Manual removal of beetles by sweep netting or other means.	Pyrethrin, Neem (multiple sprays), Milky spore disease	Tiphid parasitoids
Lace bug	Eggplant	—	—	Parasitic nematodes (drench in soil weekly)	Braconid
Leaffooted bug	Fruiting vegetables (tomato, okra, eggplant)	Timely planting of main crops, trap crop of <i>Peredovik</i> sunflower & silage sorghum <i>NK300</i> provides significant reduction	Hand-pick and destroy adults; bug vacuum may be used for removing nymphs	Pyrethrin	—
Leafhopper	Multiple crops	—	—	Insecticidal soap & oil, Pyrethrin, Neem	Flower bugs, Lacewings
Leafminer	Multiple crops	—	Pick and destroy mined leaves; remove egg clusters	Neem, spinosad, <i>Chromobacterium</i> (Grandevo)	Eulophid wasps (<i>Diglyphus</i> , <i>Dacnusa</i>) [†]
Mealy bugs	Multiple crops	—	Hand-picking	Insecticidal soap and oil	<i>Leptomastix</i> parasite [†] , <i>Cryptolaemus montrouzieri</i> predatory beetle [†]
Onion maggot	Onion	Use well-composted manure; soil tillage exposes maggots	—	—	Braconid parasitoid

[†]Denotes natural enemies that can be purchased from commercial insectaries.

TABLE 2-29. ALTERNATIVE & BIORATIONAL INSECTICIDES FOR INSECT PEST CONTROL STRATEGIES IN VEGETABLE CROPS. (cont'd)

NOTE: Results of many specific control tactics listed below are highly variable. Many have not been tested thoroughly in commercial vegetable systems.

Target Pest	Cropping System	Systems-based Practices (for pest prevention)	Mechanical & Physical tactics (for pest prevention)	Biorational Insecticides (before pests reach outbreak status)	Natural Enemies (NE) [†]
Parsleyworm (black swallowtail)	Parsley, dill, carrot	—	Hand-pick and destroy caterpillars	<i>Bacillus thuringiensis</i> kurstaki	Trichogramma wasps
Pepper weevil	Pepper	Crop rotation	Hand-pick insects	Insecticidal soap, Neem, Pyrethrin, Parasitic nematodes (drench in soil weekly)	Lady beetles, Predatory mites, Lacewings
Pickleworm	Cantaloupe, muskmelon	—	—	—	Lady beetles, Predatory mites, Lacewings
Seedcorn maggot	Snap, lima, pole beans	Reduce organic matter	—	—	Parasitoid, Parasitic nematodes
Spider mite	Multiple crops	Plant and harvest timely; provide irrigation; problem could be severe in drought years; tolerant varieties	—	Paraffinic oil, Neem oil, Sulfur dust or spray (check label before use); do not use pyrethrin	<i>Amblyseius californicus</i> [†] & <i>Phytoseiulus persimilis</i> [†] (Predatory mites), <i>Feltiella acarisuga</i> gall midge
Squash vine borer	Pumpkin, squash	Timely planting, tolerant varieties, sanitation (remove crop debris)	Practice de-worming, insect netting at plant base (early season)	Pyrethrin, Spinosad (early season spray after detecting moths or eggs at plant base)	—
Squash bug	Pumpkin, squash	Trap cropping with Hubbard squash; plant tolerant varieties, sanitation (remove crop debris)	Insect netting early in season	Pyrethrin weekly spray at low population levels	—
Stink bug & Harlequin bug	Multiple crops	Trap crop of sorghum, okra	Hand-picking	Insecticidal oil, Pyrethrin	Eucoliid & Scellionid parasitoids
Thrips	Multiple crops	Trap crops	—	Spinosad, Insecticidal soap, Paraffinic oil	<i>Orius insidiosus</i> [†] & <i>O. majusculus</i> (flower bugs), Lacewings, <i>Hypoaspis miles</i> & <i>Amblyseius swirskii</i> (predatory mites) [†]
Whitefly	Multiple crops	Crop rotation	—	Insecticidal soap, Neem oil, <i>Chromobacterium</i> (Grandevo)	Lacewings, <i>Encarsia formosa</i> [†] & <i>Eretmocerus eremicus</i> (parasitoids), <i>Amblyseius swirskii</i> (Predatory mite) [†]
Wireworms	Multiple crops	Crop rotation is a major IPM strategy	—	None	—
Yellow-striped armyworm	Multiple crops	Sanitation (remove crop debris after harvest)	Hand-picking eggs and larvae	<i>Bacillus thuringiensis</i> (Xentari, Dipel), Neem (azadirachtin), Spinosad, <i>Chromobacterium</i> (Grandevo), Azera (insecticide premix)	Spined soldier bugs

[†]Denotes natural enemies that can be purchased from commercial insectaries.

TABLE 2-25. RELATIVE EFFECTIVENESS OF INSECTICIDES AND MITICIDES FOR INSECT AND MITE CONTROL ON FIELD-GROWN VEGETABLES.

Not all insecticides listed below are registered on all vegetable crops. Refer to the label before applying to a specific crop. Ratings are based on a consensus of vegetable entomologists in the southeastern United States.

(“E” very effective; “G” effective; “F” somewhat effective; “-” ineffective or insufficient data)

Chemical class (IRAC)	Common name	Example Product	Flea Beetle	Colorado potato beetle*	Cucumber beetles	Corn earworm*	European corn borer	Fall armyworm	Cabbage looper	Imported cabbageworm	Diamondback moth*	Squash vine borer	Beet armyworm*	Stinkbugs/Harlequin bug	Squash bug	Aphids*	Thrips	Western Flower Thrips*	Leafminer	Maggots	Whiteflies*	Cutworms	Wireworms	White grubs	Spider mites*
1A	carbaryl	Sevin	E	F	G	F	G	F	F	G	F	F	-	-	-	-	F	-	-	-	-	F	-	-	-
	methamidophos	Monitor	F	-	-	G	F	F	G	-	-	-	F	G	-	E	E	G	G	-	-	-	-	-	-
	methomyl	Lannate	F	-	-	G	G	G	G	G	G	-	F	G	G	F	E	G	F	-	F	-	-	-	-
	oxamyl	Vydate	F	F	F	-	-	-	-	-	-	-	-	F	F	G	G	F	-	-	F	-	-	-	-
1B	malathion	Malathion	G	F	G	F	F	F	F	G	F	F	-	F	F	F	F	-	-	F	-	F	-	-	-
	chlorpyrifos	Lorsban	-	-	-	F	F	F	F	G	F	-	-	-	-	-	F	-	-	E	-	G	G	G	-
	acephate	Orthene	-	-	-	F	E	G	F	G	-	-	-	-	-	G	G	-	F	-	F	G	-	-	-
	diazinon	Diazinon	-	-	-	-	-	-	-	-	-	-	-	-	-	-	-	-	-	G	-	F	G	F	-
	dimethoate	Dimethoate	G	-	F	-	-	-	-	-	-	-	-	G	F	E	E	F	G	-	-	-	-	-	-
3	permethrin	Pounce	G	F	G	G	G	F	G	E	F	E	-	F	G	F	F	-	F	-	-	G	-	-	-
	alpha cypermethrin	Fastac	E	F	E	G	E	G	G	E	F	E	-	F	G	F	F	-	F	-	-	G	-	-	-
	zeta cypermethrin	Mustang Max	E	F	E	G	E	G	G	E	F	E	-	F	G	F	G	-	F	-	-	E	-	-	-
	cyfluthrin	Baythroid/Renounce	G	F	G	G	G	F	G	E	F	E	-	F	G	F	F	-	F	-	-	E	-	-	-
	lambda cyhalothrin	Karate	E	F	E	G	E	G	G	E	F	E	-	F	G	F	G	-	F	-	-	E	-	-	-
	esfenvalerate	Asana XL	G	G	G	G	G	F	G	E	F	G	-	F	F	F	F	-	F	-	-	G	-	-	-
	gamma cyhalothrin	Proaxis	E	F	E	G	E	G	G	E	F	E	-	F	G	F	G	-	F	-	-	E	-	-	-
	fenpropathrin	Danitol	G	-	G	G	G	F	F	E	F	G	-	F	G	F	F	-	F	-	F	G	-	-	F
	bifenthrin	Brigade	E	F	E	G	G	F	F	E	F	E	-	G	G	F	G	-	F	F	F	E	G	F	F
4A	imidacloprid	Admire	E	G	E	-	-	-	-	-	-	-	-	F	G	E	G	-	-	G	G	-	F	G	-
	acetamiprid	Assail	G	E	G	-	-	-	-	-	-	F	-	F	F	E	G	-	-	-	G	-	-	-	-
	clothianidin	Belay	E	E	G	-	-	-	-	-	-	-	-	-	-	G	-	-	F	G	-	-	F	G	-
	thiamethoxam	Platinum/Actara	E	G	G	-	-	-	-	-	-	-	-	G	G	E	F	-	F	G	G	-	F	F	-
4C	dinotefuran	Venom/Scorpion	E	E	G	-	-	-	-	-	-	-	-	E	E	F	G	-	F	-	G	-	-	-	-
	sulfoxaflor	Closer	-	-	-	-	-	-	-	-	-	-	-	F	-	E	-	-	-	-	-	-	-	-	-
5	spinosad	Blackhawk/Entrust	-	E	-	G	G	G	G	E	G	G	G	-	-	-	G	G	E	-	-	F	-	-	-
	spinetoram	Radiant	-	E	-	E	E	G	G	E	G	G	G	-	-	-	E	G	E	-	-	F	-	-	-
6	emamectin benzoate	Proclaim	-	-	-	G	G	G	E	E	E	G	E	-	-	-	-	-	F	-	-	F	-	-	-
	abamectin	Agri-Mek	-	E	-	-	-	-	-	-	-	-	-	-	-	-	G	F	E	-	-	-	-	-	E
7C	pyriproxyfen	Knack/Distance	-	-	-	-	-	-	-	-	-	-	-	-	-	-	-	-	-	-	G	-	-	-	-
9B	pymetrozine	Fulfill	-	-	-	-	-	-	-	-	-	-	-	-	-	E	-	-	-	-	F	-	-	-	-
9C	flonicamid	Beleaf	-	-	-	-	-	-	-	-	-	-	-	-	-	E	-	-	-	-	-	-	-	-	-
10	etoxazole	Zeal	-	-	-	-	-	-	-	-	-	-	-	-	-	-	-	-	-	-	-	-	-	-	G
11	Bt	Dipel, various	-	-	-	F	F	F	G	E	G	F	F	-	-	-	-	-	-	-	-	-	-	-	-
15	novaluron	Rimon	-	E	-	E	E	E	G	E	F	G	E	F	F	-	G	G	G	-	-	-	-	-	-
16	buprofezin	Courier	-	-	-	-	-	-	-	-	-	-	-	-	-	-	-	-	-	-	G	-	-	-	-
17	cyromazine	Trigard	-	G	-	-	-	-	-	-	-	-	-	-	-	-	-	-	E	-	-	-	-	-	-
18	methoxyfenozide	Intrepid	-	-	-	G	G	E	E	E	F	G	E	-	-	-	-	-	-	-	-	-	-	-	-
20B	acequinocyl	Kanemite	-	-	-	-	-	-	-	-	-	-	-	-	-	-	-	-	-	-	-	-	-	-	E
21	fenpyroximate	Portal	-	-	-	-	-	-	-	-	-	-	-	-	-	-	-	-	-	-	-	-	-	-	G
22	indoxacarb	Avaunt	F	G	F	E	G	G	E	E	G	G	E	-	-	-	-	-	F	-	-	F	-	-	-
23	spiromesifen	Oberon	-	-	-	-	-	-	-	-	-	-	-	-	-	-	-	-	-	-	F	-	-	-	F
	spirotetramat	Movento	-	-	-	-	-	-	-	-	-	-	-	-	-	G	-	-	-	-	G	-	-	-	-
25	cyflumetofen	Nealta	-	-	-	-	-	-	-	-	-	-	-	-	-	-	-	-	-	-	-	-	-	-	G
28	chlorantraniliprole	Coragen	-	E	-	E	E	E	E	E	E	G	E	-	-	-	F	-	E	-	G	-	-	-	-
	cyantraniliprole	Verimark/Exirel	G	E	-	E	E	E	E	E	E	G	E	-	-	G	F	F	E	-	G	-	-	-	-
	flubendiamide	Belt	-	G	-	E	E	G	E	E	E	G	E	-	-	-	-	-	F	-	-	-	-	-	-
UN	bifenazate	Acramite	-	-	-	-	-	-	-	-	-	-	-	-	-	-	-	-	-	-	-	-	-	-	E

*Denotes that insecticide-resistant populations may occur in some areas and can affect the performance of insecticides.

SUMMER SQUASH

VARIETIES ¹	AL	GA	KY	LA	MS	NC	SC	TN
SUMMER SQUASH								
Yellow Crook Neck								
Destiny III ^{3,4,5,6}	A	G	K	L		N	S	T
Dixie	A			L		N	S	T
Gentry	A	G	K		M	N	S	T
Gold Star ^{6,8}	A	G				N		
Medallion	A		K		M	N	S	T
Prelude II ^{3,4,5}	A	G	K	L		N	S	T
Supersett ^{2,4,5}	A	G		L	M	N	S	T
Yellow Straight Neck								
Cheetah ^{2,4,8}	A	G				N	S	T
Conqueror III ^{3,4,5,6,7}	A	G	K					T
Cougar ^{4,5,7}	A	G	K			N	S	T
Daisey	A	G						
Enterprise	A	G				N	S	T
Fortune ²			K			N		T
Goldbar	A	G			M	N	S	T
Lioness ^{4,5,6,7}		G	K			N		T
Multipik ^{2,4,5}	A	G	K	L		N	S	T
Solstice ^{4,5}	A	G				N	S	T
Superpik ^{2,4,5}	A	G		L		N	S	
Zucchini								
Cash Flow						N		T
Elite	A					N	S	T
Esteem ^{4,5,7,8}	A							
Judgement III ^{3,4,5,6}	A	G	K			N		T
Justice III ^{3,4,5,6}	A	G	K			N		
Leopard ^{4,7}						N	S	T
Lynx ^{4,5,7}								T
Paycheck ^{4,5,6,8}	A	G	K			N		T
Payroll ^{4,5,6,7}	A	G	K		M	N	S	T
Payload ^{4,5,6,8}	A					N	S	T
President							S	
Respect	A	G				N	S	T
Senator	A			L	M		S	T
Spineless Beauty	A	G	K		M	N	S	T
Spineless Perfection ^{4,5,8}	A					N	S	
SV6009YG ^{4,5,6,8}	A					N	S	
Tigress ^{4,5,7}	A	G	K		M	N	S	T
Total Eclipse								T
Zephyr ² (bi-color)	A	t	K			N		T
Grey Zucchini								
Ishtar	A							T
Scalloped								
Patty Green Tint	A					N	S	
Peter Pan	A		K			N	S	T
Scallopini	A	G		L		N		
Sunburst	A	G	K	L		N	S	T

¹ Abbreviations for state where recommended.

² *Py* - Precocious yellow gene; has a prominent yellow stem.

³ Transgenic.

⁴ Zucchini Yellows Mosaic virus tolerance/resistance.

⁵ Watermelon Mosaic virus tolerance/resistance.

⁶ Cucumber Mosaic Virus tolerance/resistance.

⁷ Papaya Ringspot Virus tolerance/resistance.

⁸ Powdery mildew tolerance/resistance.

Seed Treatment. Check with seed supplier to determine if seed has been treated with an insecticide and/or fungicide. Information on seed treatments can be found in SEED TREATMENT section starting on page 234.

Seeding, Transplanting, and Spacing. Use 4 to 6 pounds of seed per acre. Seed or container-grown transplants are planted when daily mean temperatures have reached 60°F. Seed as indicated in following table. Early plantings should be protected from winds with row covers, rye strips, or wind breaks. Space rows 3 to 6 feet apart with plants 1.5 to 2.5 feet apart in the row.

SUMMER SQUASH PLANTING DATES (cont'd)

	Spring	Fall
AL North	4/15–8/15	8/1–8/30
AL South	3/1–4/30	7/15–9/15
GA North	5/1–8/15	NR
GA South	3/1–4/30	7/15–9/15
KY East	5/15–7/15	NR
KY Central	5/10–8/1	NR
KY West	4/20–8/15	NR
LA North	3/15–5/15	7/15–8/31
LA South	3/1–5/15	8/1–9/15
MS North	4/15–6/15	7/25–8/14
MS South	2/15–5/1	8/14–9/14
NC East	4/1–5/30	7/15–8/15
NC West	5/15–7/31	NR
SC East	3/15–7/30	8/1–8/30
SC West	4/15–7/30	7/30–8/15
TN East	5/10–8/1	NR
TN West	4/15–7/15	NR

Mulching. Plastic mulch laid before field planting conserves moisture, increases soil temperature, reduces mechanical damage to fruit, and increases early and total yield. Plastic should be applied on well-prepared planting beds. The soil must be moist when laying the plastic. Black plastic mulch can be used without a herbicide. In most situations, 50 percent of the nitrogen(N) should be in the nitrate (NO₃) form.

Reflective, plastic mulches can be used to repel aphids that transmit viruses in fall-planted (after July 1) squash. Direct seeding through the mulch is recommended for maximum virus protection.

Growers should consider drip irrigation. See the section on “Irrigation” in this handbook.

SUGGESTED FERTIGATION SCHEDULE FOR SUMMER SQUASH* (N:K;1:2)

Days after planting	Daily nitrogen	Daily potash	Cumulative	
			Nitrogen	Potash
(lb / A)				
Preplant			24.0	24.0
0–14	0.9	1.8	36.6	49.2
8–28	1.3	2.6	54.8	85.6
29–63	1.5	3.0	107.3	190.6

* Adjust based on tissue analysis.

ALTERNATIVE FERTIGATION SCHEDULE FOR SUMMER SQUASH* (N:K;1:1)

Days after planting	Daily nitrogen	Daily potash	Cumulative	
			Nitrogen	Potash
(lb / A)				
Preplant			24.0	24.0
0–7	1.0	1.0	31.0	31.0
8–21	1.5	1.5	52.0	52.5
22–63	2.0	2.0	136.0	136.5

*Adjust based on tissue analysis.

SPECIAL NOTES FOR PEST MANAGEMENT

INSECT MANAGEMENT

Cucumber Beetle: Cucumber beetles cause direct feeding damage to the foliage. Young plants need to be protected with insecticide as soon as they emerge or are transplanted.

Squash Vine Borer: Pheromone baited sticky traps can be used soon after planting to monitor the activity of the adult moths. Start inspecting plants closely for squash vine borer eggs (1mm [1/25 inch] diameter oval, flattened, dull-red to brownish) as soon as moths are caught in the traps. The first application of insecticide should occur when eggs begin to hatch or just prior to hatching. Applications should be made in afternoons or evenings after flowers close to reduce the spraying of valuable pollinators, especially bees. If pheromone traps are not used, a preventive treatment should be applied when vines begin to run. Re-apply insecticide every seven days for four weeks. Continue monitoring the pheromone traps into August to detect the emergence of the new moths. When moths are caught, inspect plants for second-generation eggs, and begin the insecticide applications when eggs first begin to hatch or just prior to hatching.

Aphids: Aphid feeding can delay plant maturity. Thorough spray coverage, especially on the underside of the leaves is important. Treat seedlings every five to seven days, or as needed. The transmission of plant viruses by aphids has the potential to be the most damaging to the crop. Unfortunately, insecticide use for aphids does not reduce the spread of virus. A better approach is the application of Stylet Oil to fill tiny grooves between the leaf cells. When the aphid probes the leaf surface, its stylet must pass through a layer of oil. This reduces the infectivity of the virus resulting in less disease in the squash plant. The application of Stylet Oil can delay virus infection, but requires application every other day, thorough coverage and high-pressure sprays. Also, refer to the preceding “Mulches” section for information on metallized reflective mulch used to repel or disorient aphids that can spread viruses.

Squash Bug: Begin scouting shortly after plant emergence. Treat every 7 to 10 days when adults or nymphs appear. The control of squash bugs is particularly important where yellow vine disease occurs since squash bugs vector the pathogen responsible for this disease.

Spider Mites: Mite infestations generally begin around field margins and grassy areas. CAUTION: DO NOT mow these areas after midsummer because this forces mites into the crop. Localized in-

festations can be spot-treated. **Note:** Continuous use of Sevin or pyrethroid sprays may result in mite outbreaks.

DISEASE MANGEMENT

Cucurbit Downy Mildew Forecasting System: Cucurbit downy mildew (CDM) is a devastating foliar Cucurbit disease. While difficult, if not impossible to control, CDM can be prevented by using effective IPM practices. A useful tool for prevention of CDM is the CDM forecasting system. This program depends on the accurate reporting of CDM in the field as well as the monitoring of over 50 strategically placed sentinel plots. These plots are monitored by Plant Pathologists at multiple Land Grant Universities throughout the United States and Canada. Forecasts of the epidemic movement of the disease are generated 3 times a week. Risk maps are produced from these forecasts. For forecasts, maps, local contacts and other helpful information please visit our website, <http://cdm.ipmpipe.org>. If you think you have CDM, please contact your local Extension office.

Viruses (CMV, WMV, PRSV and ZYMV): Plant infection by viruses often causes squash fruit to be distorted or off-color rendering them unmarketable. Certain yellow-fruited varieties contain the precocious (*Py*) gene. The varieties are distinguished by their yellow stem. Varieties with the *Py* gene should be used for late spring or summer plantings since viruses are more prevalent in the summer than spring plantings. The *Py* varieties can normally mask virus fruit symptoms of certain viruses for several harvests. Use resistant varieties where possible, but even these may not escape virus.

WEED MANAGEMENT

See the previous “Mulching” section for further information on weed control under clear plastic mulch.

For Seeding into Soil without Plastic Mulch. Stale bed technique: Prepare beds 3 to 5 weeks before seeding. Allow weed seedlings to emerge and spray with paraquat a week prior to seeding. Then seed beds without further tillage.

For Soil Strips between Rows of Plastic Mulch. Use the following land preparation, treatment, planting sequences, and herbicides labeled for squash, or crop injury may result.

1. Complete soil preparation and lay plastic and drip irrigation before herbicide application.
2. Spray preemergence herbicides on the soil and the shoulders of the plastic strips in bands before weeds germinate. **DO NOT APPLY HERBICIDE TO THE BED SURFACE OF THE PLASTIC.** Herbicides may wash from a large area of plastic into the plant hole and result in crop injury.
3. Incorporate herbicide into the soil with 1/2 to 1 inch of rainfall or overhead irrigation within 48 hours of application and **BEFORE PLANTING OR TRANSPLANTING.**
4. Apply selective postemergence herbicides broadcast or in bands to the soil strips between mulch to control susceptible weeds.

POLLINATION

Honey bees are important for producing high yields and quality fruit. Populations of pollinating insects may be adversely affected by insecticides applied to flowers or weeds in bloom. Apply insecticides only in the evening hours or wait until bloom is completed before application. See section on “Pollination” in the General Production Recommendations.

HARVESTING AND STORAGE

See Table 14 for postharvest information.



Small Fruit and Vegetable Production



Session 3 Crop Rotation

David Berle, Associate Professor
Horticulture Department
University of Georgia

Learning Objectives

- What is crop rotation?
- Benefits of a good crop rotation program
- Determine best crop rotation for individual situation

What is crop rotation?

- Planting different crops over time
- Alternating crops with different growth habits
- Growing plants for the benefit the soil
- Using plants to help manage a pest



Benefits of crop rotation

- Build soil fertility
- Covers the soil when not growing cash crop
- Increase economic returns
- Add to crop and market diversity
- Help control of weeds, diseases, and insects



Crop rotation and cover crops

- Cover crops as trap crops
 - Capture leftover nitrogen after harvest of cash crops.
 - Prevent this nitrogen from leaching or running off
- Cover crops help distribute phosphorous and potassium



Photos: Lindsay Davis and Katie Chatham

Crop rotation for pest management

- Crop rotation is essential to both conventional and organic growers
- Farmers who implement a good crop sequence must consider two things at once:
 - How to deal with pests that are shared by crops in rotation?
 - How a previous crop can help reduce pests for the next crop?



Crop rotation for disease management

- Alternating crops helps break disease cycle
- *General rule:* a two-year rotation will reduce the incidence of foliar diseases (leaf)
- A four-year rotation that includes a succession of crops not susceptible to the same pathogens will minimize problems from soil borne diseases.



Crop rotation for disease management

Wanna B Farm Crop Rotation

Year 1: Buckwheat> Winter Squash> Oats/Austrian Winter Peas

Year 2: Tomatoes> Oat/Winter Pea> Sunn Hemp> Kale/Broccoli> Rye

Year 3: Field Peas> Oats/Winter Pea> Lettuce> Buckwheat> Okra

Note: Crops in squash family not grown in the same place for three years. This will reduce soil borne disease pressure and leaf diseases. The same principal applies for tomato family and cabbage family.



Photos: Jessica Cudnik, Lindsay Davies, and Katie Chatham

Crop rotation for insect management

- Insects have specific environmental requirements to live
- Crop rotation disrupts insect habitats
- Crop rotation breaks the life cycle of insects
- Not all insects are easily managed with crop rotation



Crop rotation for weed management

- Plan rotations to make it difficult for weeds to grow
- Disturbing the soil slows weed growth
 - Certain crops can suppress weeds by out-competing them



Rotation for pest management

Rule of thumb: Establish a rotation of crops that are hosts to entirely different sets of pests, have different growth habits, and are dissimilar in other respects.



Crop rotation planning

- No hard and fast rules
- At a minimum:
 - Same crop should never follow itself in the same field (or bed)
 - A cover crop should be planted after vegetables every year
- Plan at least a year ahead of time
- Don't worry about solving every problem with each planting- think long term

	Jan	Feb	Mar	Apr	May	Jun	Jul	Aug	Sep	Oct	Nov	Dec
Year 1												
Year 2												
Year 3												

Crop rotation planning

- Case studies have several examples of crop rotations
- These are examples but not applicable to all situations



Additional Resources

- Using Cover Crops in the Home Garden (C 1057) (UGA Extension)
- Success with Cover Crops (EB 102) (UGA Extension)
- Cover Crops for Sustainable Production (<https://growingsmallfarms.ces.ncsu.edu/growingsmallfarms-covcropindex/>)





This material is based upon work that is supported by the National Institute of Food and Agriculture, U.S. Department of Agriculture, under award number 2015-70017-22861.

USDA Beginning Farmer and Rancher
Development Program
Developing the Next Generation
of Sustainable Farmers in Georgia Grant





Small Fruit and Vegetable Production



Session 3 Pest Management

Dr. David Berle
Associate Professor
Horticulture Dept
University of Georgia

Learning Objectives

- Name the four part strategy of sustainable pest management
- List three sustainable weed management practices
- List three sustainable insect management practices
- List three sustainable disease management practices

Why are pests important?

- Pests waste resources
- Pest reduce yields
- Pests cost \$\$\$\$

Pest Management System

- Step 1: Identify pest
- Step 2: Understand ecology of pest
- Step 3: Determine impact of pest
- Step 4: Select strategy that is least expensive and least harmful Step 5: Document management practices and results

Preventative pest management strategies

- Require advance knowledge and planning
- Often best options for organic growers
- Don't ignore basics
 - Fertility
 - Water management
 - Variety selection

Pest monitoring and impact

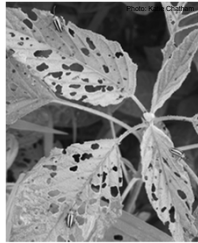
- Scouting to determine presence or level of damage
 - Personal observation
 - Traps and nets
 - Stage of pest and stage of crop
- Thresholds
 - Varies with crop and insect
 - For some crops, thresholds have been established
 - For crops without established thresholds
 - Observation
 - Trial and error

Chemical strategies

- Insects
 - Most kill insect on contact
 - Some disrupt life cycle
- Diseases
 - Some kill disease, others make environment bad for disease development
 - Few organic chemical options
- Weeds
 - Mostly pre-emergent
 - Few organic herbicides
- Read and follow pesticide labels

Insect pests

- Insects are efficient eating machines
- Why insect management important?
 - Reduce productivity and yield
 - Reduced visual appearance
 - Spread of diseases through vectors
 - Crop death
- Beneficial insects versus insect pests



Insect identification

- Insect website: <http://www.ent.uga.edu/insectid.htm>
- Insects: 3 body parts (head, thorax, and abdomen)
- 6 legs (spiders have 8)
- Compound eyes, 1 pr.(2) antennae

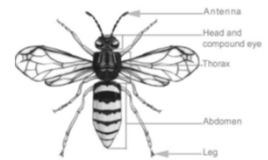


Photo: <http://gen.uga.edu/documents/pest/1%20am%20an%20Insect.pdf>

Insect ecology

- Life cycles
 - Incomplete (Egg>Nymph>Adult)
 - Complete (Egg>Larvae>Pupae>Adult)
- Insect feeding
- Insect habitat
- Insect behavior

Insect Management Strategy (example)

- Step 1: Identify pest
- Pest recognition and identification
 - You see signs of leaf feeding
 - Maybe you see frass
 - You identify as a tomato hornworm

Insect management strategy

- Step 2: Understand ecology of pest
 - 2 to 4 generations of these pests in Georgia
 - Often overwinter in pupae stage
- Step 3: Determine impact of pest
 - Rarely a bad pest
 - Often parasitized by a number of predatory insects

Insect management strategy

- Step 4: Select least expensive strategy that is least harmful
 - Hand pick
 - Use *Bacillus thuringiensis* (B.t.) bacteria while the caterpillars are small
- Step 5: Document management practices and results

Plant diseases

- What is a disease?
- Economic importance of plant diseases?
 - Reduce yields
 - Damage harvestable portion of crop
 - Affect crops AFTER harvest
 - Inability to grow some crops at all
 - Cost to manage



What causes plant disease?

- Bacteria
- Fungi
- Oomycetes
- Viruses
- Nematodes
- Abiotic

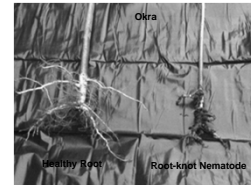
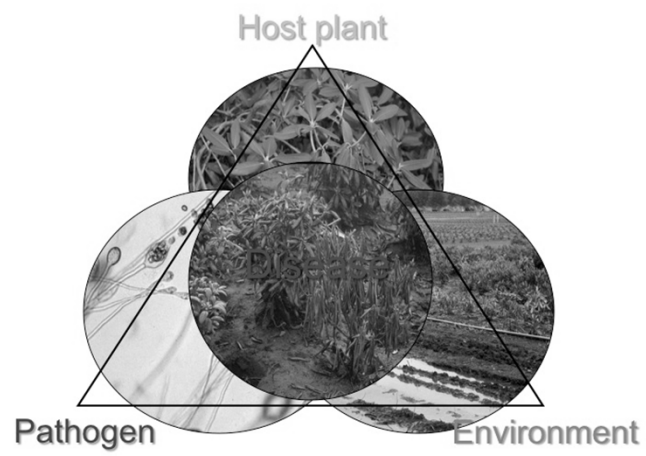


Photo: Julia Gaskin

Disease triangle



http://horticulture.oregonstate.edu/system/files/u551/Slide1_0.jpg

“Managing” the disease triangle

- You can't change the climate, but you can change what you grow, when you grow it and how you grow it
- Manipulating the environment
 - Plant spacing, irrigation management, drainage
- Manipulating the host
 - Resistant varieties, crop rotation, pathogen-free seed
- Manipulating the pathogen
 - Removal of infected plants, chemicals (organic/non-organic)

JOURNEYMAN FARMER
CERTIFICATE PROGRAM

So you think you have a disease ...

- Step 1: Identification (<http://plantpath.caes.uga.edu/extension/DiseaseLibrary.html>)
- Step 2: Research pathogen ecology
- Step 3: Determine impact
- Step 4: Select best management option
- Step 5: Document management practices and results

JOURNEYMAN FARMER
CERTIFICATE PROGRAM

Disease prevention strategies

- Crop rotation
- Polyculture cropping patterns
- Sound soil fertility management
- Water management
- Resistant crop varieties



Photo: Julia Gastin

JOURNEYMAN FARMER
CERTIFICATE PROGRAM

Weeds

- Definition of a weed
- How do weeds cost a grower?
 - Compete for water, light and nutrients
 - Reduce yield
 - Cost of management
 - Harbor insect and disease pests
 - Allelopathic effects
 - Difficult accessing crops

JOURNEYMAN FARMER
CERTIFICATE PROGRAM

Weed ecology

- Life cycle
 - Annual versus Perennial
- Season of growth
 - Summer (warm-season)
 - Winter (cool-season)



JOURNEYMAN FARMER
CERTIFICATE PROGRAM

So you have a weed problem..

- Step 1: Weed identification (<http://weedid.missouri.edu/>)
- Step 2: Weed ecology
- Step 3: Weed impact
- Step 4: Weed management
- Step 5: Document management practices and results

JOURNEYMAN FARMER
CERTIFICATE PROGRAM

Weed prevention strategies

- Minimize potential for spread of noxious weeds
 - Thoroughly clean equipment
 - Do not allow weeds to form seed heads
 - Thoroughly compost all imported animal manure
 - Filter surface irrigation water

JOURNEYMAN FARMER
CERTIFICATE PROGRAM

Weed management strategies

- Planting
- Cultivation
- Mulches
 - Organic
 - Plastic and fabric
- Herbicides
- CROP ROTATION
- Other practices
 - Flame
 - "Stale bed"



JOURNEYMAN FARMER
CERTIFICATE PROGRAM

Learning Activity – Pest Management Strategy

- Work through the pest problem using the 5-step strategy of pest management

JOURNEYMAN FARMER
CERTIFICATE PROGRAM

Additional Resources

- **2015 Georgia Pest Management Handbook**
<http://www.ent.uga.edu/pest-management/>
 - Free PDF online or purchase book
- **2015 Georgia Pest Management Handbook Homeowner Edition**
<http://extension.uga.edu/publications/detail.cfm?number=SB48>
 - UGA Extension Publication SB 48 Free PDF online or purchase book

JOURNEYMAN FARMER
CERTIFICATE PROGRAM



This material is based upon work that is supported by the National Institute of Food and Agriculture, U.S. Department of Agriculture, under award number 2015-70017-22861.



USDA Beginning Farmer and Rancher
Development Program

Developing the Next Generation
of Sustainable Farmers in Georgia Grant





Small Fruit and Vegetable Production



Session 3 Pesticide Safety

David Berle
Horticulture Dept
University of Georgia



Learning Objectives

- Recognize differences (and similarities) between organic and conventional pesticides
- Understand pesticide toxicity rating system
- Basics of pesticide safety on the farm



Pesticides for pest management

- Laws and regulations
 - Georgia Pesticide Use and Application Act
 - National Organic Program (OMRI)
- ALL materials applied to control pests are "pesticides"
- ALL pesticides must be approved and labeled for specific crops
- Remedies/organic pesticides are subject to same regulations
- Organic pesticides are not necessarily safer than conventional pesticides... it depends



Pesticide toxicity

- All pesticides are evaluated for toxicity by the US government
- The toxicity value is called LD₅₀
- The lower the LD₅₀, the greater the toxicity

Pesticide	LD ₅₀ (mg/kg)
Roundup	4,300
Caffeine	192
Table Salt	3,000
Pyrethrum	1,000
Sevin Dust	500
Orthene	866



Photo: [http://www.caes.uga.edu/commodities/spray/pubs/documen](http://www.caes.uga.edu/commodities/spray/pubs/documen%20ts%20HAND%20PDF)



Pesticide safety on the small farm

- Apply pesticides after careful review
- Read the label
- Mix and clean in a separate area
- Pay attention to waiting times
- Store pesticides properly
- Keep accurate records



Photo: <http://www.caes.uga.edu/>



For information on pesticide application

- Georgia Department of Agriculture- Pesticide Division
(<http://agr.georgia.gov/pesticides.aspx>)
- USDA Organic Standards (National Organic Program)
(<http://www.ams.usda.gov/grades-standards/organic-standards>)





This material is based upon work that is supported by the National Institute of Food and Agriculture, U.S. Department of Agriculture, under award number 2015-70017-22861.

 **USDA** Beginning Farmer and Rancher
 **NIFA** Development Program
Developing the Next Generation
of Sustainable Farmers in Georgia Grant



Session 3: Resource Page

Crop Rotation

Using Cover Crops in the Home Garden

<http://extension.uga.edu/publications/detail.cfm?number=C1057>. UGA Extension Publication C 1057.

Success with Cover Crops

<http://extension.uga.edu/publications/detail.cfm?number=EB102>. UGA Extension Publication EB 102.

Cover Crops for Sustainable Production

<https://growingsmallfarms.ces.ncsu.edu/growingsmallfarms-covcropindex/>

Pest Management

2015 Georgia Pest Management Handbook

<http://www.ent.uga.edu/pest-management/> Free PDF online or purchase book.

2015 Georgia Pest Management Handbook Homeowner Edition

<http://extension.uga.edu/publications/detail.cfm?number=SB48>
UGA Extension Publication SB 48 Free PDF online or purchase book.

Insect Identification – UGA Entomology – <http://www.ent.uga.edu/insectid.htm>

Bugwood Network – <http://www.bugwood.org/>

Southeastern Vegetable Crop Handbook - <http://www.thepacker.com/grower/2015-southeastern-us-vegetable-crop-handbook>

Disease Identification - <http://plantpath.caes.uga.edu/extension/DiseaseLibrary.html>

Weed Identification - <http://weedid.missouri.edu/>

Pesticide Safety

Georgia Department of Agriculture- Pesticide Division

<http://agr.georgia.gov/pesticides.aspx>

USDA Organic Standards National Organic Program

<http://www.ams.usda.gov/grades-standards/organic-standards>

NOTES:



Small Fruit and Vegetable Production

Seasonality; Crop Selection;
Vegetable Propagation, Seeds,
Transplants; Considerations for Small
Fruit Production

Session Four

Facilitator Notebook

Session 4: Seasonality; Crop Selection, Vegetable Propagation, Seeds and Transplants; Considerations for Small Fruit Production Facilitator Agenda

Homework Discussion (5 min)

Who viewed the Pesticide Safety Video? Any questions?

Seasonality (15 min – Dr. Tim Coolong, Horticulture Dept., University of Georgia)

- Georgia seasons and crops

Learning Objectives:

- Recognize if a particular crop is a warm or cool season crop

Crop Selection (30 min- Dr. Tim Coolong, Horticulture Dept., University of Georgia)

- Matching soils, climate, landscape position, amount of sun, and markets to your cash crop using examples; open pollinated vs. hybrids and disease resistance; determinate vs. indeterminate

Vegetable Propagation, Seeds, Transplants (35 min – Dr. George Boyhan, Horticulture Dept., University of Georgia)

- Direct seeding and transplants – crop suitability, when and why conditions might favor one or the other
- Basic transplant production and handling – seeding, seeding mixes, watering, hardening off
- Small fruit management – Soil requirements, fertilization, pruning, staking; resources for varieties in Georgia and management

Learning Objectives:

- Give an example of a crop that should be direct seeded
- List three reasons you might want to use a transplant

Learning Activity (30 min) – Locally Yours Farm Transplant Worksheet

Calculating number of seeds and transplants.

Ask class to find Locally Yours Farm Transplant worksheet. Have the class work through the worksheet and then discuss answers as a class.

Considerations for Small Fruit Production (10 min-Dr. George Boyhan, Horticulture Dept., University of Georgia)

- Name three resources for small fruit production

Session 4 – Locally Yours Farm Transplant Worksheet Key

(Directions to Facilitators are in italics, Directions to participants are in bold)

Locally Yours Farm wants to grow two 5 x 20 ft (100 ft²) beds of summer squash this year for an early market. In their biointensive system, the squash spacing is 12 inches triangular for 33 plants per bed.

They have chosen Gentry, a good variety for the South. The germination rate on the packet is 80%. Each packet has 30 seeds.

Assume they need to grow 10% to 20% more plants than they need in order to select the best for transplanting. The germination rate of the seed bought this year is high so this will account for that also. One seed should be placed in each tray plug.

How many transplants should they start? How many seeds do they need? How many seed packets do they need?

1. Number of transplants desired 66 = 33 number of plants/bed x 2 beds

Ask them to pull out the seed packets they brought in and look for the germination rate. What are the range of germination rates listed? In general, if the seed packet lists the germination rate use this to calculate how much seed to sow. With 80% germination you should sow a minimum of 83 seeds to get the desired 66 plants.

2. Number of seeds corrected by germination rate 83 = $66 / (80\% / 100)$ or $66/0.8$

With transplants, it is a good idea to sow more seed than needed, to be able to choose the healthiest plants. It is common to plant 10-20% more than the minimum. Don't over seed because this is wasteful and seed is costly. Each cell should be sown with a single seed.

3. Number of transplant cells to be seeded 100 = 17 number of extra transplants based on germination rate x (20 percent extra/ 100) + 83 number transplants based on germination rate

4. Number seeds needed 100 = number of cells to be seeded

There are 30 seeds to a packet, so in this case, they would need to buy 4 packets.

5. Number of seed packets 4 = 100 / 30 seeds per packet

Topics for discussion:

1. *What type of crops do you direct seed? Which do you transplant?*
 - a. *Lots of different answers here, we are going to focus on squash, tomatoes, and spinach/beets/carrots.*
 - i. *Squash-You can either transplant or direct seed squash. What sort of circumstances may affect your decision? Weather-if drought or very rainy, may be best to grow transplants and plant into the ground when plants are older and stronger. Space-if you don't have room in a greenhouse then direct seeding is a better option.*
 - ii. *Tomatoes-Tomatoes are usually transplanted*
 - iii. *Spinach/beets/carrots-These are normally direct seeded. They don't like having their roots disturbed once they are planted.*
2. *What would be good tools for a small farm like Locally Yours to use for seeding? What about a medium scale farm, Gittin' There Farms?*
 - a. *Small farm-push seeder or hand seeding*
 - b. *Medium farm-Single or double row planter*



Small Fruit and Vegetable Production



Session 4 Vegetable Growing Seasons in Georgia

Timothy Coolong PhD
Commercial Vegetable Extension Specialist
University of Georgia, Tifton Campus



Georgia Growing Seasons



- Georgia can be divided into 3 growing regions
 - Mountains (Rome, Rabun, Blairsville)
 - Piedmont (Athens, Atlanta)
 - Coastal Plain (S. GA, Tifton)



Georgia Growing Seasons

- In the Mountains and Piedmont frost protection provides clear advantages for markets
- In S. GA year-round production of vegetables occurs

• First/Last Frost Dates

Location	First Frost	Last Frost
Blairsville	9/23-11/6	3/31-5/21
Watkinsville	10/9-11/25	3/5-4/19
Tifton	11/1-12/21	1/26-3/21

Dates gathered from data from 1994-2015 time period



Warm and cool season crops

- Many warm season crops are fruiting crops (pepper, cucumber, tomato)
- Many cool season crops the leaves are consumed (cabbage, greens, lettuce)
 - There are exceptions - bulbs and root crops (beets) are cool season
 - Some root crops (sweet potato) are warm season
- While you can grow crops out of season expect to encounter more problems under less than optimal conditions
- Season extension techniques

JOURNEYMAN FARMER
CERTIFICATE PROGRAM

Cool Season Crops

- The following crops will tolerate frosts and freezes
 - Onion (15-18 °F)
 - Cabbage (20-22 °F)
 - Greens, Spinach (18-24 °F)
 - Broccoli/Cauliflower (24-30 °F)
 - Carrot (22-24 °F)
 - Lettuce (24-28 °F)

- Freeze/frost tolerance is related to species as well as
 - Growing conditions
 - Stage of growth



Damage to mustard greens after cultivation and cold weather

JOURNEYMAN FARMER
CERTIFICATE PROGRAM

Warm Season crops

- All of these crops will be damaged by frost
 - Solanaceous crops (tomato, pepper, eggplant)
 - Cucurbits (cucumber, watermelon, cantaloupe, squash)
 - Sweet corn
 - Beans, Peas
 - Okra, sweetpotato



Lettuce bolting

JOURNEYMAN FARMER
CERTIFICATE PROGRAM

Days to maturity

- Days to maturity are an estimate only
 - Ex. Sweet corn in spring and fall can differ by 20 days in maturity
 - Think in terms of heat units
 - Most warm season crops use a base temperature of 50 °F for growth

- Days to maturity cont.
 - Differ based on a direct seeded or transplanted crop
 - Beans are 50-55 days from seeding to maturity
 - Peppers may be 70-75 days from transplanting (6 week old transplant)

JOURNEYMAN FARMER
CERTIFICATE PROGRAM

Growing seasons

- N. GA Mountains
 - 1 warm season crop
 - 1-2 cool season crops
 - Planting warm season May 1 (estimate)
 - Cool season crops planted March and August
- Piedmont
 - 1 or 2 warm season crops (2 short season crops such as squash/cucumber)
 - 2 cool season crops
 - Plant warm season early-mid April and early August
 - Cool season March and August

JOURNEYMAN FARMER
CERTIFICATE PROGRAM

Growing season

- S. GA
 - 2 warm season crops
 - 2 cool season crops
 - Warm season planted late Feb-late March and Aug 1-Aug 15
 - Cool season planted mid Jan-early Feb and Aug 15-Sept 15
- In the southern part of the state the second warm season crop will be under severe disease and insect pressure
 - Disease resistance in varieties is critical

JOURNEYMAN FARMER
CERTIFICATE PROGRAM

Transplant production

- For many fall crops transplant production can be challenging
 - Seeded and grown during the hottest time of the year
 - Germination rates of cool season crops suffer in heat
- Direct seeded fall crops (carrot, bean) need to have constant wetting of the soil to prevent crusting and improve germination.

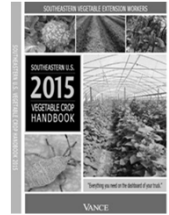


Photo: Tom Costello

JOURNEYMAN FARMER
CERTIFICATE PROGRAM

Additional Resources

- General planting dates for GA
 - Vegetable gardening in GA
 - <http://extension.uga.edu/publications/detail.cfm?number=C963>
 - SE Regional Vegetable Production Guide
 - <http://www.thepacker.com/grower/2015-southeastern-us-vegetable-crop-handbook>



JOURNEYMAN FARMER
CERTIFICATE PROGRAM

JOURNEYMAN FARMER
CERTIFICATE PROGRAM

Supported by

USDA Beginning Farmer Rancher
Development Program
Developing the Next Generation
of Sustainable Farmers in Georgia Grant





Small Fruit and Vegetable Production



Session 4 Crop Selection

Timothy Coolong PhD
Extension Vegetable Specialist
University of Georgia, Tifton Campus



Learning Objectives

- Basic crop and variety selection –
 - Matching soils, climate, landscape position, amount of sun, and markets to your cash crop using examples
 - Open pollinated vs. hybrids and disease resistance
 - Determinate vs. indeterminate

Site Selection/Plan

- Most important considerations for site selection
 - Have good water
 - Horticulture Crops contain 90% water must have plenty of water
 - Soil Quality
 - It might take a while but you can really improve soil over time
 - Well drained soils are preferred over those that drain poorly
 - Drain tile may be an option – vegetable crops do not tolerate standing water



R.J. Reynolds Tobacco Company. Bagwood.org - See more at: <http://www.iprimagis.org/browse/66341.cfm?imgnum=144005&thout.MP&w=673.dpuf>

Variety and Crop Selection

- Hybrid (F1) vs. Open Pollinated (OP)
- Hybrids are a controlled cross between 2 inbred parental lines
 - Have vigor
 - Do not look like parents
 - Have improved disease resistance (typically)
 - Most new varieties
 - Cannot save seed – they will not come true to type



Varieties and Crop Selection

- Open pollinated
 - Older types – heirloom vegetables are open pollinated – some new releases are also OP.
 - Can save seed from these and they will be true to type
 - Often lack disease resistance that newer varieties have
 - Seed are typically much cheaper
 - May differ significantly between companies
 - Hybrids are usually associated with a single company, while OP types can be sold by several sources

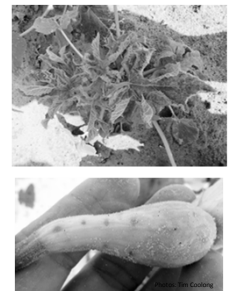


GMO vegetables

- Although GMO crops grab a lot of headlines they have a very minor impact on vegetables
 - Commercially there are GMO sweet corn (herbicide and insect resistance) and squash/zucchini (virus resistance)
 - Very little GMO sweet corn is grown by large wholesale growers
 - GMO Squash is limited to the fall market in Georgia (enhanced disease resistance)
 - Other GMO vegetables have patents issued but are not sold commercially

Variety Selection

- Disease resistance in varieties is a critical tool to us
 - Often disease resistance is not present in varieties with certain quality characteristics
- As the season progresses, disease resistance becomes more important (inoculum and vectors increase)
 - For ex. In spring non-virus resistant squash can be grown, but that becomes challenging later in the summer



Disease resistance



Cross pollination

- Most different species will not cross pollinate
 - Interspecific hybrids can occur
 - Not an issue since the fruit will not be affected, only the seed
- Generally self pollinate (perfect flowers)
 - Beans, peas, tomatoes, peppers
- Cross pollinate w/ insects (male/female flowers)
 - Cucurbits
- Cross pollinate w/wind
 - Corn

Sweet corn types

- There are at least 9 types of sweet corn available now
- Most come from 3 genes and combinations
- Su (standard sweet corn)-5-15%
- Se (sugary enhanced) – 8-20%
- Sh2 (shrunk 2/super sweet) 25-40%

Sugary enhanced

- Has either one or two copies of the recessive *se-1* gene
- Either 25% or 100% kernels contain the *se* characteristics
- Works in conjunction with the recessive *su-1* gene (regular sweet corn)
- Produces extra sugars, but does not slow starch conversion
- Tend to be creamy, do not ship well – sold for direct markets

Supersweet (*Sh-2*)

- Supersweets contain a recessive gene of *sh-2*
- This increases sugar and prevents the conversion of sugars to starch
- They lack the production of phytyglycogen (starch)
 - Why they are not creamy
- Also do not germinate well because no starch available
- Ship very well and are sold on the wholesale market



Sh-2 kernel,
Harris Moran Seed Company

In summary

- Se, Su, Synergistics can grow together
- Sh-2, and augmented supersweets can be grown together
- Keep the two groups isolated
- Isolation 250 feet will get minor contamination
- Isolation of 700 feet will be complete
- 10-14 days of maturity/planting time

Other varietal characteristics to be aware of...

- Tomatoes
 - Indeterminate vs. determinate
 - Indeterminate will continue to grow, eventually getting very tall
 - Many heirloom types
 - Harvest spread out over a long period
 - Determinate will terminate in a flower bud (fruit cluster) after a set time period
 - Hybrid types, shorter more compact, concentrated yields



Determinate tomatoes in a field

Systems-based farming

Photo: Tim Coolong

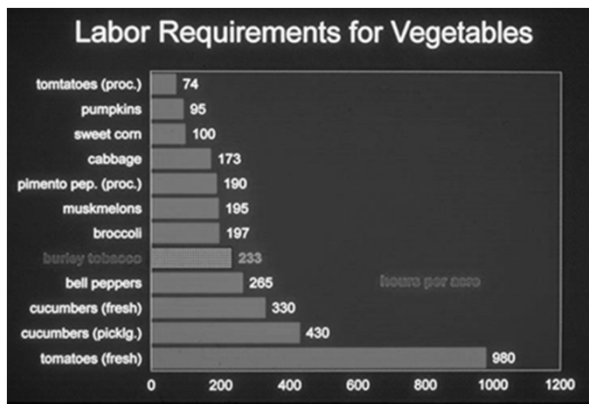
Crop Selection

- #1 – Grow what you can sell and have it sold before you plant it
- #2 – Can it fit into your production system
 - Weed and pest control, post-harvest treatment, labor, etc.



Photo: Tim Coolong

Crop Selection



Slide courtesy of Dr. Brent Rowell, University of Kentucky.

- Labor is a significant factor in crop selection.
 - Tomatoes are widely regarded as the most labor intensive

Crop Selection

- How does the crop grown fit into your system
 - Example weed management for a crop
 - Decisions made regarding selecting a crop



JOURNEYMAN FARMER
CERTIFICATE PROGRAM

Will you use herbicides?

- What herbicides are available? <http://www.gaweed.com/>
- Do they have rotation restrictions?
- Can they be used on a variety of crops



JOURNEYMAN FARMER
CERTIFICATE PROGRAM

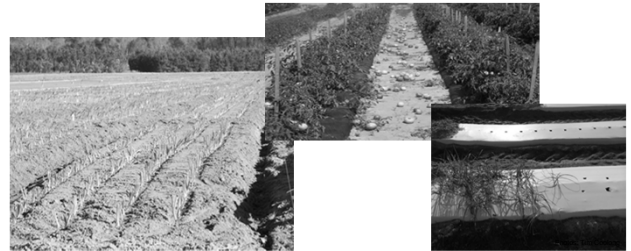
What will you grow

- Staked or vining-how will you cultivate



JOURNEYMAN FARMER
CERTIFICATE PROGRAM

Plastic or Bare Ground?



JOURNEYMAN FARMER
CERTIFICATE PROGRAM

Crop Selection

- Short season vs. long season



JOURNEYMAN FARMER
CERTIFICATE PROGRAM

Crop Selection

- Quick coverage vs. poor competitors



JOURNEYMAN FARMER
CERTIFICATE PROGRAM

Crop Selection Storing Vegetables

Not all vegetables should be refrigerated

- Cool and dry
 - Room temperature or slightly cooler (~ 60F)
 - ~ 60% relative humidity
- Cool and "moist"
 - ~ 55-60 F, refrigeration for a few days generally ok
 - Protect from drying (silted plastic bag, slightly open container)
- Cold and moist
 - Refrigerated (32-40 F)
 - ~ 95% relative humidity



Storing Vegetables

- Cool and dry
 - Potatoes
 - Pumpkins/winter squash
 - Watermelons
- Cool and "moist"
 - Cucumbers
 - Summer squash
 - Eggplant
 - Peppers
 - Tomatoes
- Cold and moist
 - Beans
 - Beets
 - Broccoli/cauliflower
 - Cabbage
 - Cantaloupe
 - Carrots
 - Corn
 - Leafy greens (lettuce, spinach, kale)
 - Radishes



Additional Resources

- SE Regional Vegetable Production Guide
 - <http://www.thepacker.com/grower/2015-southeastern-us-vegetable-crop-handbook>
- GA Pest Management Handbook
 - <http://www.ent.uga.edu/pest-management/>



Supported by
USDA Beginning Farmer and
NIFA Rancher
Development Program
Developing the Next Generation
of Sustainable Farmers in Georgia Grant





Small Fruit and Vegetable Production



Session 4 Vegetable Propagation, Seeds and Transplants

Dr. George Boyhan
Horticulture Dept.
University of Georgia



Learning Objectives

- Give an example of a crop that should be direct seeded
- List three reasons you might want to use a transplant

Crop Propagation

Goal is:

- Consistent stand maximize use of space
- Straight rows helps with weed control
- Proper spacing for best plant growth, reducing weeds and disease

Either direct seeding or transplanting can work.

Direct Seeding vs Transplanting

- Direct seeding advantages
 - Don't need greenhouse for transplant production
 - Better for root crops like carrots, beets, turnips
 - Better for thickly seeded leaf crops – lettuce mixes, microgreens
 - Always used for cover crops
- Direct seeding disadvantages
 - Usually requires more seed
 - Less control of germination conditions
 - Smaller window for production

Direct Seeding vs Transplanting

- Transplanting advantages
 - Insures a perfect or near perfect stand
 - Extends growing season
 - Production for early markets
 - Save on irrigation
 - Improve crop uniformity
 - Save on expensive seed
- Transplanting disadvantages
 - Initial investment in greenhouse infrastructure
 - Extra labor to produce transplants



Direct Seeding -Getting Started

- Good bed or ground preparation for good seed-soil contact
- Know the right planting depth!
- Know the right spacing!

You can find this information on many seed packets or in the seed catalog.



Seeding Equipment & Methods

- Hand seeding
- Broadcasting
- Drilling – planting one seed next to another
 - Cover crops
- Precision sowing –best stand establishment for specific spacing
- Chitting – pre-germinate seed until radical appears
- Precision seeders
 - Plates
 - Belts
 - Vacuum

Seeding Equipment & Methods

- Handseeding
 - Place stake with string, pull tight to mark straight row
 - Pull hoe along string to make furrow at right depth
 - Walk along furrow and drop seeds in at right spacing
 - Use hoe to cover furrow
 - Water



Seeding Equipment & Methods

- Handseeding in biointensive beds
 - Offset rows to plant in triangles to maximize plants in a given space

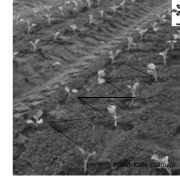
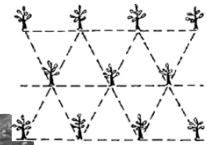


Photo: <http://www.nodf.org> - Planting Trees: An Illustrated Technical Guide and Training Manual

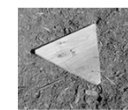


Photo: <http://simple-green-fruitful-coop.blogspot.com>

Seeding Equipment & Methods

- Push seeders
 - Have different plates for right spacing for different crops
 - Row markers can be set for right row spacing

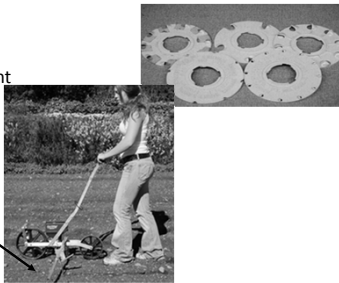
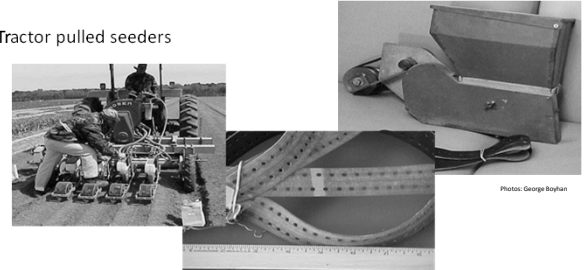


Photo: <http://www.johnnyseeds.com/>

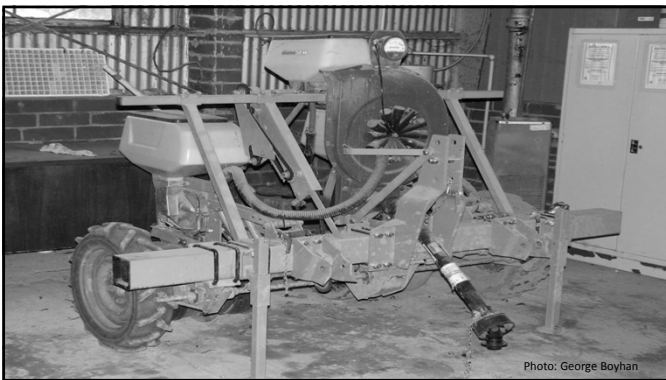
Seeding Equipment & Methods

- Tractor pulled seeders



Photos: George Boyhan

Seeding Equipment & Methods



Seeding Equipment & Methods

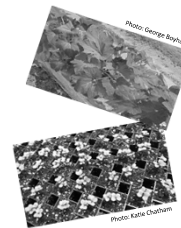


Transplant Production

- Is it cost effective?
- How much seed?
- When to plant?
- Containers, media, fertilizer?
- Handling and transportation?
- Field grown bareroot production
- Sets – specialized reproductive structure
 - (ex. onions)

Commonly Transplanted Vegetables

- Broccoli
- Brussels sprouts
- Cabbage
- Cauliflower
- Celery
- Collards
- Cantaloupe
- Cucumber
- Eggplant
- Lettuce
- Onion
- Pepper
- Sweetpotato
- Tomato
- Watermelon
- Squash



Field Production

- Large industry in south Georgia years ago
 - Limited current production
 - Ex. Bonnie Plant Farms - Union Springs, AL
- Onions – still a significant industry
 - On-farm production



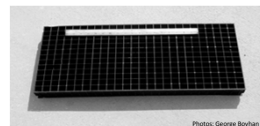
Transplant media and containers

- Peat based media
 - Peat moss, perlite, vermiculite, pine bark
- Other additives
 - Lime, fertilizer (enough for the crop, organic water soluble fertilizers are not available)
- Containers
 - Speedling trays, flats & inserts, single piece polyethylene flats



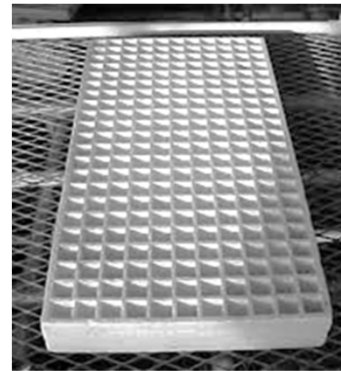
Example Potting Mix

- Organic media mix:
 - 0.4 yard sphagnum peat moss or ground pine bark
 - 0.3 yards vermiculite or perlite
 - 0.3 yards compost or topsoil (ex. Black Cow Topsoil)
 - 4 cups complete organic fertilizer (ex. 5-6-6)
 - 1 cup blood meal
 - 5 lbs ground limestone



Tray cell sizes

- Standard flat 11 x 22 inches
- 36, 50, 63, 72 cells per flat
- Other sizes available
- Seedling trays
 - Slightly larger 13.5 x 26.5 inches
 - Sold by the number of cells per tray
 - Ex. 242 cells per tray (1" square, 2" deep)



Photos: George Boyhan

Transplant Timing

Crop	Seed/10,000 seedlings	Germination (days)	Time Required (weeks)
Broccoli	2 oz	4-9	5-7
Cucumbers	0.5-1.0 lbs	3-7	2-3
Eggplant	4 oz	5	5-7
Muskmelon	0.5-1.0 lbs	3-7	4-5
Pepper	7 oz	8	5-7
Pumpkin	2.5-6.5 lbs	3-7	2-3
Onion	3 oz	4	8-10
Squash	2-3 lbs	3-7	2-3
Tomato	3 oz	5	5-7
Watermelon	3.25 lbs	3	3-4

Adopted from Knott's Handbook for Vegetable Growers

Transplants Per Acre

Crop	Transplants/acre
Broccoli	17,500 – 26,250
Cabbage	12,500 – 23,200
Cucumbers	14,500 – 19,300
Eggplant	4,000 – 6,000
Muskmelon	2,000 – 5,500
Pepper	9,300 – 14,500
Pumpkin	1,000 – 3,000
Onion	80,000 – 100,000
Squash	9,600 – 14,500
Tomato	9,300 – 14,500
Watermelon	1,600 – 3,000

Activity – Seed Numbers and Transplants

- *Locally Yours Farm* wants to grow two 5 x 20 ft beds of summer squash this year for an early market. How many transplants should they start? How many seeds do they need?

JOURNEYMAN FARMER
CERTIFICATE PROGRAM

Special Handling

- Triploid Watermelon
 - Expensive seed
 - Keep media on dry side
 - Particularly 1st 48-72 hrs
 - High temperature
 - Above 70 deg. F. nights
 - Coordinate with pollinizer production



Photos: George Boyhan

Transplant Finishing & Handling

- Size (1-3 inch diameter cells)
 - Smaller the size the more care required (watering etc.)
- Disease or insect problems
- Hardening off
- Delivery
- Delay in Planting



JOURNEYMAN FARMER
CERTIFICATE PROGRAM

Hardening Off

- Reduce water and/or temperature
 - Move out of the greenhouse 3-5 days prior to transplanting
 - Protect from excessive cold (move back to greenhouse at night if needed)
 - Protect from excessive light (place in the shade and/or watch the watering)
- Effects
 - Reduces growth
 - Thickens cuticle
 - Increases dry matter
 - Increases water holding colloids
 - Decreases free water
 - Anthocyanins increase
 - Increase carbohydrates



Photo: John Galatin

JOURNEYMAN FARMER
CERTIFICATE PROGRAM

Transplanting

- Similar to direct seeding – mark off row
- Make hole with hoe or dibble at correct spacing or
- Use hand transplanter
- Put in transplant
- Step on side to close hole
- Water



JOURNEYMAN FARMER
CERTIFICATE PROGRAM



JOURNEYMAN FARMER
CERTIFICATE PROGRAM

Additional Resources

- Maynard, D.N. and G.J. Hochmuth. 2007. Knott's Handbook for Vegetable Growers 5th Edition. John Wiley & Sons, Inc. Hoboken, NJ. ISBN-13: 978-0471-73828-2.



JOURNEYMAN FARMER
CERTIFICATE PROGRAM

JOURNEYMAN FARMER CERTIFICATE PROGRAM

This material is based upon work that is supported by the National Institute of Food and Agriculture, U.S. Department of Agriculture, under award number 2015-70017-22861.

USDA Beginning Farmer and Rancher
Development Program
Developing the Next Generation
of Sustainable Farmers in Georgia Grant





Small Fruit and Vegetable Production



Session 4 Considerations for Small Fruit Production

Dr. George Boyhan
Horticulture Dept.
University of Georgia



Learning Objectives

- Name three resources for small fruit production.



Small Fruits for Sustainable Production

• Definition: Perennial crop producing small fruit.

- Blueberries
- Muscadines
- Blackberries
- Strawberries (often grown as an annual)



Photo: www.stoffusmarket.com/Fruit-Trays.html



Blueberries

- Rabbiteye – main season varieties
- Southern Highbush – early maturing, challenging to grow, not recommended in mountain regions
- Plant multiple varieties to insure proper pollination
- Acid soils – pH 4.5-5.2
- Plant with peat moss or pine bark to insure acidity
- No lime
- Cane renewal pruning after establishment (4-6 ft)
- Very few problems



Photo: pendergardner.blogspot.com/2010_06_01_archive.html



Muscadines

- Adapted to the Southeast
- Immune to Pierce's Disease
- Grown on trellis
- Plant multiple varieties to insure pollination
- Training & pruning is required
 - Fruit on new growth from last year's wood

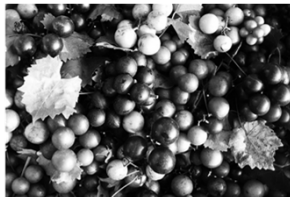


Photo: <https://penotr.ces.ncsu.edu/2012/08/its-time-for-muscadines>



Blackberries

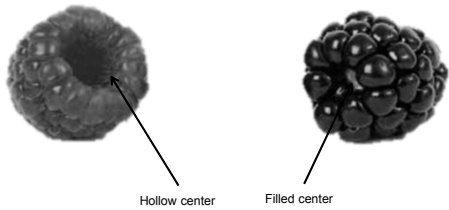
- Brambles – includes blackberries, raspberries, etc.
- Raspberries are not well adapted to the south
- Erect, semi-erect, & trailing types
- Fruit produced on two-year-old canes (floricanes)
 - Current year's growth are called primacanes
 - Cane renewal pruning - floricanes are removed after fruiting



Photo: <http://today.agrilife.org/2012/11/14/horticulturist-tells-how-to-have-a-berry-good-farm-in-least/>

JOURNEYMAN FARMER
CERTIFICATE PROGRAM

Raspberries versus blackberries



Photos: <http://www.examiner.com/article/how-to-tell-blackberries-from-black-raspberries>

JOURNEYMAN FARMER
CERTIFICATE PROGRAM

Stiles Shift Trellis



Photo: seamusbus.blogspot.com/...blackberries-on-shift-trellis.html



Photo: www.sdebbie.org/blackberry-care-cultivars.html

JOURNEYMAN FARMER
CERTIFICATE PROGRAM

Strawberries

- Annual Hill Culture versus Matted Row
 - AHC results in larger fruit, less disease
 - AHC requires more management and are usually grown on plastic
- Plastic mulch requires all fertility preplant
 - No water soluble organic fertilizers
 - Fertility management can be problematic
- Overwintering crop that requires frost protection
 - Overhead irrigation and/or row covers



JOURNEYMAN FARMER
CERTIFICATE PROGRAM

Strawberries

- Important to establish fall planted transplants prior to winter weather
- Obtain healthy disease free plants
 - Certified organic growers must obtain organically grown transplants

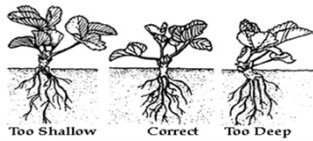


Figure 1. Set plants deep enough so all of the roots are covered, but making sure the crown is above the soil line. The plant on the left is too shallow and the one on the right is set too deep. The roots should extend straight downward

Photo: <http://i.vad.yimgprode.ru/ta2ovaya-zemlyanka/ta2ovaya-zemlyanka>

JOURNEYMAN FARMER
CERTIFICATE PROGRAM

Additional Resources

- Grow Your Own Organic Small Fruits - <http://www.sustainagga.org/documents/OrganicSmallFruits-brochure.pdf>
- Organic Blueberry Production - <http://www.sustainagga.org/documents/06organicblues2.pdf>
- SustainAgGA.org – Go to Resources, Crops, Small Fruits

JOURNEYMAN FARMER
CERTIFICATE PROGRAM

Session 4: Resource Page

Seasonality

Vegetable Gardening in GA

<http://extension.uga.edu/publications/detail.cfm?number=C963>

UGA Extension Publication C 963, General planting dates for GA

SE Regional Vegetable Production Guide

<http://www.thepacker.com/grower/2015-southeastern-us-vegetable-crop-handbook>

Crop Selection

SE Regional Vegetable Production Guide

<http://www.thepacker.com/grower/2015-southeastern-us-vegetable-crop-handbook>

GA Pest Management Handbook

<http://www.ent.uga.edu/pest-management/>

Crop Propagation and Management

Knott's Handbook for Vegetable Growers 5th Edition

Maynard, D.N. and G.J. Hochmuth. 2007. John Wiley & Sons, Inc. Hoboken, NJ. ISBN-13: 978-0471-73828-2.

Commercial Production of Vegetable Transplants

UGA Extension Publication – B 1144

<http://extension.uga.edu/publications/detail.cfm?number=B1144>

Considerations for Small Fruits

Grow Your Own Organic Small Fruits

<http://www.sustainagga.org/documents/OrganicSmallFruits-brochure.pdf>

Organic Blueberry Production

<http://www.sustainagga.org/documents/06organicblues2.pdf>

Resources, Crops, Small Fruits

www.SustainAgGA.org

NOTES:



Small Fruit and Vegetable Production

Irrigation, Equipment and Tillage

Session Five
Facilitator Notebook

Session 5 – Irrigation, Equipment and Tillage Facilitator Agenda

Ideally this session should be a farm tour of two different farms: a small scale and mid-scale farm. Participants enjoy and learn a lot from actually being on a farm and we strongly encourage you to use this option. If farm tours are not possible, we have a classroom option available. The classroom option is based on group discussion of the three case studies illustrating the different approaches to irrigation, equipment, and tillage at different scales. This will require preparation on your part to lead the discussion.

Learning Objectives:

- List three reasons to have an irrigation system for your crops
- Recognize how tillage effects the physical, chemical and biological properties of the soil
- Give an example of an appropriate planter for a 1 to 2 acre farm

If you are setting up a Farm Tour:

Look for a small scale farm that uses largely human or walk behind tractors for tillage, weeding etc. Find at least one other farm that would be using tractors for primary and secondary tillage and possibly cultivation. It is best if the farmers can at least show participants the equipment they use and possibly demonstrate some equipment. **Plan on this session running over 2 hours. You may want to hold the session on a different day or at a different time to accommodate a larger time period. Please let your participants know what to expect for the timeline of the day.**

Prepare the farmer hosting the tour that they should:

1. Set the stage in terms of a general description of their farm, the history of the farm, the production area, major crops, how and where they sell their crops.
2. Describe how they manage weeds and the equipment they use for cultivation.
3. Describe how they prepare the ground for growing.
4. Describe how they plant and transplant crops.
5. Describe their irrigation equipment and how they know when to irrigate.

If a farmer doesn't cover these areas, prompt them with questions.

1. How old is your farm? Why did you start farming? What do you grow? How much land do you have? Where do you sell your crops? How do you market your products?
2. Do you use cover crops? Manure? Compost?
3. What small-size equipment do you use? What equipment would you recommend for a small or medium sized grower? Can you show us some of your equipment and possibly demonstrate some?
4. What are your major weeds? How do you deal with them?

5. Do you use transplants or direct seeding? Do you have a greenhouse?
6. What do you use to irrigate? Where does your water come from? How often do you irrigate? How do you know when to irrigate? Can you show us some of your irrigation?

Additional questions you could ask for good discussion of other topics:

1. What sort of pests and diseases do you have the most issue with?
How do you deal with them?
2. Do you hire labor for the farm? If so, how many people and how many hours per week?
3. How do you store your produce? What sort post-harvest facilities do you have? How do you package and transport produce to market?
4. How do you keep good records? Any record keeping programs you would recommend?
5. How do you deal with food safety?
6. What advice would you give a new farmer?

If you are conducting a class discussion of the Case Studies:

If you are conducting a class discussion of the case studies, lead the discussion below with your group. Feel free to bring in some equipment to show the class, for example walk behind tractor, push seeder, irrigation supplies.

Use the case study Power Point for this discussion. For each scale, discuss the choices made for irrigation, equipment, and tillage and then compare and contrast these. Some questions you might pose to start the discussion are below:

1. Wanna B and Gittin' There Farms both use drip irrigation. What are some advantages to drip? What are disadvantages?
 - a. Advantages-Good amount of water applied directly to the base of the plant which helps cut down on disease, doesn't encourage weed growth between plants, don't lose much water to evaporation, can regulate how much water you are giving to plants, better for food safety since water is not being applied to leaves/fruit.
 - b. Disadvantages-Can be expensive to purchase everything needed for drip irrigation, can be difficult to get small seeded vegetable crops to germinate with drip, small sprinklers would be better for direct seeded crops. Takes a good amount of time to set up your plots, have to dispose of plastic drip tape. Mice like to gnaw tape and so you should plan for leaks.
2. For a large scale farm operation, what might be the advantage and disadvantage of the big reel gun that Gittin' There Farms uses?

- a. Advantage-Portable, able to move and set up as needed around the farm. Don't need to spend much time on initial set up, as opposed to drip irrigation.
 - b. Disadvantage-Labor moving the reel, force of droplets on small plants can damage them, water splashing can cause disease and food safety issues, less efficient water use.
3. What does Locally Yours do to reduce tillage impacts on their soil?
 - a. Very small scale, can use broadfork and rake for bed prep in the spring and then transplant without additional tillage.
 4. How does Wanna Be Farms prepare beds for planting?
 - a. Tractor for primary tillage, walk behind tractor for bed prep.
 5. As they grow their farm, what might Wanna Be Farms want to change?
 - a. Buy their own tractor and be able to use it for bed prep and possibly shallow cultivation of weeds.
 6. Why did Gittin' There Farm buy a spader?
 - a. One pass incorporation of cover crops then shallow cultivation for weeds helps to preserve soil and reduce labor time for bed prep.
 7. How does weed control change as you increase scale?
 - a. Hoes and hand weeding in Locally Yours, then hoes and wheel hoes in Wanna Be Farm, tractors and field cultivators in Gittin' There Farm as well as plastic.
 8. What are positives and negatives of using plastic mulch like Gittin' There Farm does?
 - a. Advantages-Helps to keep weed pressure lower on crops that don't shade them out or are in the ground for a longer period of time, like onions or winter squash
 - b. Disadvantages-Cost of plastic, another step in your farming process, plastic has to be picked up after use, plastic can rip in some sections, increased reliance on fossil fuel
 9. Why doesn't Locally Yours Farm utilize cover crops like the other two farms do?
 - a. Mostly because of their size and their biointensive methods. They always have crops growing in their beds. In order to supplement their soil, they do add compost and some amendments once a year. Also, Wanna Be Farm and Gittin' There Farm have the equipment to mow and till in the cover crops.

10. What can Wanna Be Farms do with a walk behind tractor that Locally Yours Farm cannot do? What are the advantages and disadvantages of using any sort of tiller?
- Till more deeply, plow, mow, make beds. This piece of equipment costs several thousand initially but can save a lot of time for farmers on a bigger scale than Locally Yours Farm. Locally Yours Farm utilizes the double digging method and rototilling, but at a very small scale they may be able to prep the beds in the spring and transplant in new crops throughout the year without remaking beds.
 - Advantages-Tilling makes ground easier for planting and breaks up weeds.
 - Disadvantages-Tilling releases carbon, can disrupt beneficial microorganisms, it can create a plow pan of 6-8 inches
11. What are a few vegetables that Wanna Be Farms might use a hand seeder to plant with? What do they use a broadcast seeder for?
- Carrots, beets, sweet corn, radish, peas, beans, turnips, etc. These crops do well directly seeded into the soil, as opposed to being grown as a transplant in a greenhouse.
 - Cover crops can be broadcast seeded, or planted with a seeder for a more uniform stand. Larger scale operations can use or rent a drill.
12. Gittin' There Farms was able to get a cost share from NRCS to help install pipes for their irrigation. What is a cost share? What is NRCS?
- NRCS is the Natural Resource Conservation Service. They are part of USDA and have several programs that farmers can apply to for conserving natural resources. One example is the EQIP-Environmental Quality Incentive Program. If a farmer is enrolled NRCS will reimburse them for a portion of the cost of the practice. For example, if a farmer is using overhead spray irrigation, then EQIP program can help them install the infrastructure for drip irrigation.
13. As folks looking to start farms, what sort of irrigation are you thinking of using? What sort of equipment? Do you have any of these items already or are you going to have to purchase them? Any suggestions about what you've liked and used thus far?



Small Fruit and Vegetable Production



Session 5 Case Study Discussion

David Berle and Tim Coolong, Horticulture Dept UGA
Julia Gaskin, Crop & Soil Science Dept UGA
Tensio Seanima, Georgia Organics



Case Study 1: Very Small Farm (< 1 acre) Locally Yours Farms

Land:

- Three sites: Two growing areas and a separate post harvest handling area

Production area

- Site 1 – 1/2 acre of raised bed vegetables, small fruit-tree orchard and compost pile
- Site 2- 700 sq. ft. growing area, 2 high tunnels, and 20 fruit trees



Photo: Tensio Seanima

Markets

- Direct through e-commerce website, pop-up farmers market at pre-schools and nearby grocery, and farmers' market.
- Commercial sales to restaurants
 - *Market niche is locally grown, fresh vegetables*



Case Study 1: Very Small Farm (< 1 acre) Locally Yours Farms

Crops

- Summer - squash, cucumbers, tomatoes, peppers, beans, okra
- Fall and spring - kale, mustards, collards, onions, and garlic
- Example crop rotation:

• Year 1

- Spring Crop - Spring garlic & onions, mature garlic & onion
- Summer Crop – Tomatoes or peppers,
- Fall Crop - Kale, collards, mustard

• Year 2

- Spring Crop – Carrots
- Summer Crop – Cucumbers or summer squash
- Fall Crop - Lettuce

• Year 3

- Spring Crop – Beets or Swiss chard
- Summer Crop – Bush beans
- Fall Crop – Arugula, mesclun mix micro greens



Photo: Tensio Searima



Case Study 1: Very Small Farm (< 1 acre) Locally Yours Farms

Ground Preparation

- Front-tine rototiller
- Beds double dug periodically to minimize use of rototiller

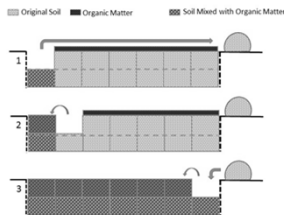
Cultivation

- Weeds – Intensive planting, sheet mulching, and hand weeding
- No further cultivation after seedbed preparation



Double digging – often done for initial bed preparation

- Technique where top 6" to 12" of soil are removed
- Lower 6" to 12" is loosened with pitchfork and organic matter added
- Top soil in next block is shoveled into first block
- Repeat
- Subsequent tillage can also be done with broadfork, pitch fork and rake to level and prep seedbed
- NOTE: Don't bring up hard red clay to surface when using this technique



Case Study 1: Very Small Farm (< 1 acre) Locally Yours Farms

Planting

- Most vegetables transplanted; direct-seeded crops planted by hand

Irrigation

- Hand watering with hoses or watering cans

Equipment

- Front tine rototiller
- Hand tools
- Hose & nozzle, watering can
- Hand-held sprayer



JOURNEYMAN FARMER
CERTIFICATE PROGRAM

Case Study 2 – Small Farm (2 acres) Wanna B Farms

Land

- Rented 10 acres land with house, 5 acres open land

Production area

- 2 acres,
 - Vegetables- 0.5 acres at one time
 - Herbs- 0.25 acres

Markets

- Direct through CSA, farmers' market and self-serve roadside stand
 - *Market niche is unusual, heirloom and new vegetables with fresh herbs*



JOURNEYMAN FARMER
CERTIFICATE PROGRAM

Case Study 2: Small Farm (2 acres), Wanna B Farms

Crops

- Summer - squash, tomatoes, beans, peppers, and culinary herbs such as basil oregano and thyme
- Fall and spring - kale, lettuce, cabbage, onions, potatoes, spinach, carrots, dried herbs
- Crop rotation
 - Year 1: Buckwheat> Winter Squash> Oats/Austrian Winter Peas
 - Year 2: Tomatoes> Oat/Winter Pea> Sunn Hemp> Kale/Broccoli> Rye
 - Year 3: Field Peas> Oats/Winter Pea> Lettuce> Buckwheat> Okra



JOURNEYMAN FARMER
CERTIFICATE PROGRAM

Case Study 2: Small Farm (2 acres), Wanna B Farms

Ground Preparation

- Neighbor with tractor and plows paid for ground preparation
- Beds bed shaped and finished with tiller attachment



Cultivation

- Hand hoes and wheel hoes

Planting

- Push seeder
- Hand held broadcast seeder for cover crops
- Hand transplanting



Sprayers

- Solo backpack sprayer and 30-gallon battery powered sprayer



Case Study 2: Small Farm (2 acres), Wanna B Farms

Irrigation

- Well (10 gallons per minute) with T-style filter
- 1" PVC pipe connected to drip tubes w/ in-line emitters



Equipment

- Walk behind tractor (tiller, rotary plow, brush mower)
- Push seeder and broadcast seeder
- Wheel hoes, hoes, shovels and rakes
- Backpack sprayer and 30-gallon battery powered sprayer



Case Study 3: Mid-scale Farm (14 acres) Gittin' There Farms

Land

- 14 acres in production, began with 2 acres

Production area

- 2 acres mixed vegetables for direct markets
- 12 acres mixed vegetables for wholesale market



Markets

- Began at farmers' market, after 2 years expanded to multi-farm CSA, after 5 years expanded to wholesale
 - Market niche is local produce



Case Study 3: Mid-scale Farm (14 acres) – Gittin’ There Farms

Crops

- Spring/Summer - squash (yellow and zucchini), cucumber, snap beans, southern peas, tomato (several varieties), pepper (several varieties), eggplant, sweetcorn (successional plantings to extend harvest) and sweetpotato
- Fall/winter - greens (kale, turnip, mustard and collards), broccoli, potatoes (late winter/early spring), beets, carrots and onions
- Example wholesale crop rotation:

- Year 1:
 - Early summer legume cover crop
 - Fall greens (kale, collards, etc)
 - Spring hard squash
- Year 2:
 - Sweet potatoes
 - Winter grain/legume mix cover crop
- Year 3:
 - Sweet corn – Late summer buckwheat cover crop
 - Winter grain cover crop
 - Spring snap beans or lettuce
- Year 4:
 - Summer legumes
 - Onions



JOURNEYMAN FARMER CERTIFICATE PROGRAM

Case Study 3: Mid-scale Farm (14 acres) – Gittin’ There Farms

Ground Preparation

- Cover crops mowed with flail mower pulled by 75 HP 4wd tractor
- First pass with rotary spader to turn in cover crops
- After week, shallow cultivation with field cultivator to destroy weeds and prep seedbed
- After another week, final shallow cultivation
- Small plastic layer used to lay plastic on onions beds to prevent weeds



Cultivation

- Sweep cultivator for between rows
- Hand hoes for in row (between the plants)



JOURNEYMAN FARMER CERTIFICATE PROGRAM

Case Study 3: Mid-scale Farm (14 acres) – Gittin’ There Farms

Planting

- Planter
- Push seeder
- Broadcast seeder for cover crops
- Finger style tobacco transplanter

Sprayers

- 8 row boom sprayer with 200 gallon tank
- Backpack sprayer



JOURNEYMAN FARMER CERTIFICATE PROGRAM

Case Study 3: Mid-scale Farm (14 acres) – Gittin' There Farms

Irrigation

- Well (10 gallons per minute) with small pond for storage
- Irrigation pump and big gun reel irrigation
- 2" PVC pipes to some plots for drip tape



Equipment

- 75 HP 4wd tractor
- Harrow
- Rotary spader
- Field cultivator
- Small plastic layer
- 8 row boom sprayer with 200 gallon tank
- Backpack sprayer and assorted hand tools
- Big gun reel



Additional Resources

- Use of Tillage in Organic Farming Systems: The Basics - <http://articles.extension.org/pages/18634/use-of-tillage-in-organic-farming-systems:-the-basics>
- Steel in the Field – A Farmers Guide to Weed Management Tools - <http://www.sare.org/Learning-Center/Books>
- Equipment and Tools for Small-Scale Intensive Crop Production ATTRA - <https://attra.ncat.org/attra-pub/summaries/summary.php?pub=373>





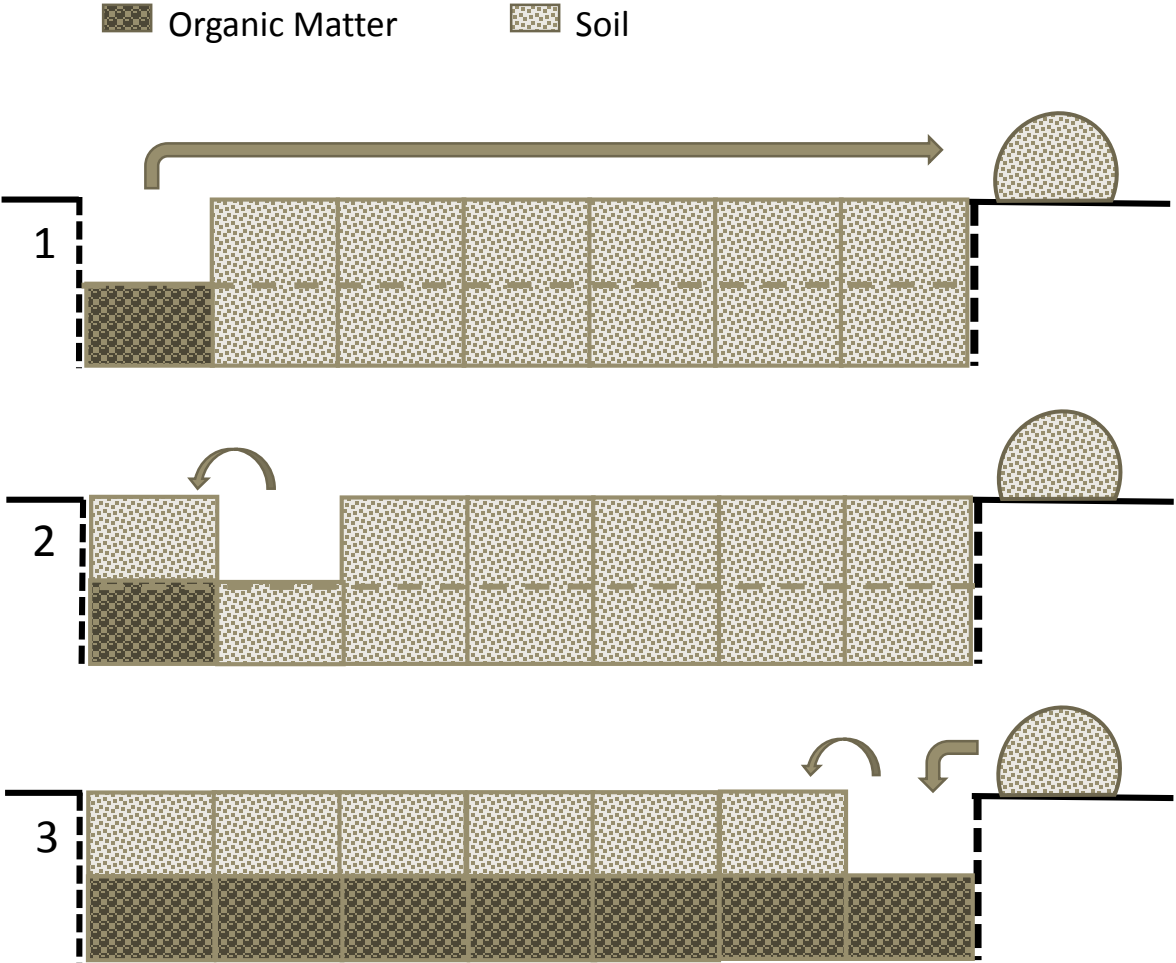
This material is based upon work that is supported by the National Institute of Food and Agriculture, U.S. Department of Agriculture, under award number 2015-70017-22861.

USDA Beginning Farmer and Rancher
Development Program
Developing the Next Generation
of Sustainable Farmers in Georgia Grant



Small Fruit and Vegetable Production

Session 5: Double Digging Diagram



Equipment and Tools for Small-Scale Intensive Crop Production

By Andy Pressman,
 NCAT Sustainable
 Agriculture Specialist
 Published September
 2011
 © NCAT
 IP417

This publication focuses on equipment and tools for intensive crop production on a small-scale commercial farm. It details equipment and hand tools for soil preparation, planting, and weed management. The use of appropriate equipment and tools, both in terms of size and practicality, can increase production efficiency and profits while minimizing the disturbance to soil and to plant health. A list of further resources and tool and equipment suppliers is included.

Introduction/Overview

The use of appropriate agricultural equipment and tools for small-scale intensive crop production contributes to the viability of the farm by enhancing production efficiency. Equipment and tools are necessary for plant propagation, soil preparation, planting, pest and weed control, irrigation, harvesting, postharvest handling, storage, and distribution. Sustainable agriculture can be a labor-intensive business and by selecting the appropriate tool for the task at hand, farmers can increase profits by increasing crop yields, improving crop quality, and reducing expenses. Factors to consider when choosing appropriate agricultural equipment and tools include the location and growing conditions of the farm, the type of crops being grown, the production practices being used, and how the crops will be marketed.

In the past, the volume of business—or size of the farm—was the most important factor in yielding a profit (Kains, 1973). Many small-scale farmers today are generating high profits from land bases that are five acres or less. Practical farmers at this scale are able to sustainably manage their production and their farm finances, which are the result of reasonable capital costs and low annual operating expenses. Farms intensively producing on five acres or less rely on the versatility of their manual labor but also may utilize mechanized equipment to maximize production efficiency.

Tools and equipment should relate to the scale of production, and compromises are necessary as farming systems transition from a hand-labor



The author's Farmall 140 with belly-mounted implements. Photo: Andy Pressman, NCAT

scale to a tractor scale. Limiting the number of different row spacings, limiting the number of different bed widths, and designing beds that consider slope, soil erosion, and tractor-wheel widths are important considerations when scaling up production to include a tractor and implements. It is also important to consider how best to match the right equipment to the cropping system, including such factors such as how the soil and plants are managed and how the use of cover crops and crop rotations is incorporated. Diversified cropping systems can complicate matters because various crops require different row spacing, which means the implements may need to be adjusted for each crop.

Equipment for small-scale intensive crop production tends to be simple and less specialized than equipment for larger-scale production. As a result, the equipment is often affordable and requires less capital. The economics of owning and maintaining farm machinery may appear

Contents

Introduction/ Overview	1
Hand Tools	2
Tractors, PTOs, and Toolbars.....	2
Walk-Behind Tractors.....	3
Soil Preparation	3
Seeding and Planting	6
Weed Control.....	7
Summary	12
References	12
Further Resources	12

The National Sustainable Agriculture Information Service, ATTRA (www.attra.ncat.org), was developed and is managed by the National Center for Appropriate Technology (NCAT). The project is funded through a cooperative agreement with the United States Department of Agriculture's Rural Business-Cooperative Service. Visit the NCAT website (www.ncat.org/sarc_current.php) for more information on our other sustainable agriculture and energy projects.



to be complicated and even overwhelming. Renting or borrowing equipment may be an option for some farmers; however, investing in appropriate and practical equipment that matches the whole-farm cropping system can result in a minimal increase in cost per hour. The investment pays off in hand-labor savings, even after costs such as labor for the driver, fuel, maintenance, and equipment depreciation are factored in. A 2005 study published by the Center for Integrated Agriculture found market vegetable farms using sustainable farming practices invest between \$2,011 and \$26,784 per acre in equipment (Hendrickson, 2005).

Small-scale farms tend to invest in used equipment primarily due to the high cost of new equipment and the fact that new equipment available in the U.S. is generally no longer designed for small-scale production. Many small-scale farmers are finding new equipment to meet their scale of production from manufacturers located overseas and are working with local distributors, investing in the costs of having it imported, or having it fabricated locally. Many of the tools mentioned in this publication are of European origin. No matter where it is manufactured, generating a profit after the initial investment of purchasing the equipment also depends on the associated costs of maintaining, storing, and repairing it (Grubinger, 1999).

Although draft-animal power does find a place on many sustainable small farms, this publication does not include a discussion on equipment for draft power. However, many of the implements described in this publication were originally designed for the horse and can be used with both draft and tractor power. Refer to ATTRA's *Draft Animal Power for Farming* for information on the use of draft animals.



Hand tools for small-scale intensive crop production. Photo: Andy Pressman, NCAT

Related ATTRA Publications www.attra.ncat.org

Draft Animal Power for Farming

Conserving Fuel on the Farm

Market Gardening: A Start-Up Guide

Flame Weeding for Vegetable Crops

Pursuing Conservation Tillage Systems for Organic Crop Production

There are a number of characteristics that determine appropriate agricultural tools (Village Earth, 2011):

- They should allow for efficient and speedy work with a minimum of fatigue.
- They should be safe.
- They should have a simple design that allows them to be made locally.
- They should be light for easy transportation.
- They should be ready for immediate use without preparatory adjustments that cost time.
- They should be made of readily available materials.

Hand Tools

There are two key components to consider when selecting a hand tool for commercial crop production: ergonomics and durability. Ergonomics refers to how a tool is best designed for comfort, efficiency, safety, and productivity. The more ergonomically designed a tool is, the easier it will be on the human body. The length of a handle, the type of handle grip, the weight of the tool, and the angle of the tool head to the handle affect the ergonomics of a tool.

The more durable a tool is, the longer it will last without sustaining significant damage or wear. Durability can be measured in the strength of the handle and tool head. The harder the steel used for the tool head, the better it will hold an edge—which in turn improves efficiency and reduces wear. How the tool head and handle are joined together also affects the durability of the tool and determines whether parts can be replaced.

Tractors, PTOs, and Toolbars

One horsepower is equal to the force required to raise 33,000 pounds one foot in one minute.

Tractors provide the power to push and pull farm machinery and are designed with one thing in mind: utility. The best type of tractor to use should be determined by the farm's acreage, physical layout, and soils, as well as the tasks the tractor is needed for and the implements that will be mounted to it. Small-scale farms do not need large quantities of horsepower for mechanical tillage or weed cultivation. For intensive crop production, farmers generally can achieve

their goals with tractors in the 5- to 30-horsepower range, but may need up to 30 additional horsepower for deep tillage.

In 1939, Ford Motor Company came out with the 3-point hitch on its Model N tractors. Prior to this time, the brand of most implements had to match the brand of the tractor because each manufacturer had its own way of hitching its implements to its own tractors. The 3-point hitch allows for implements to be easily attached to a tractor so that the tractor carries the weight of the implement. Although single and double hitches served in a similar capacity, the 3-point hitch allowed for the implement to be lifted by the tractor's hydraulic system. As a result, the depth of the implement could be controlled; therefore, the load on the tractor also was controlled. The 3-point hitch became standardized in the 1960s, making different manufacturers' tractors and implements compatible.

A toolbar also can be used to attach implements to a tractor and can be set up with multiple implements that can work in conjunction with one another. A shank is used to attach the tool, such as a sweep or shovel, to the toolbar. Depending on how much action, or mobility, is needed by the tool, different types of shanks can be used. For example, C-shanks vibrate slightly, S-shanks vibrate aggressively, and straight shanks are firm.

Starting in 1947, manufacturers began adding a built-in transmission device known as a power take-off (PTO) to tractors. The PTO allows the tractor to power an implement while the tractor is being driven. PTOs are a main feature on tractors today, including walk-behind tractors.

Many of the tractors from this era are preferred by small-scale farmers who practice intensive



A three-point hitch. Photo: Andy Pressman, NCAT

crop production. A well-cared-for older tractor can run for years and is much more affordable than a new tractor for small-scale production. Not only was the horsepower designed for this scale of farming, the mechanical systems are not as complicated as they are on newer tractors, and parts are relatively easy to come by and install.

Walk-Behind Tractors

A walk-behind tractor, or walking tractor, can be an effective, even essential, tool for small-scale farming. At five to 14 horsepower, these two-wheeled power sources can provide a farm that is two acres or less with its necessary tillage and cultivation needs. Their versatility also allows them to be used in combination with a 4-wheeled tractor to manage a few acres of production. Walk-behind tractors are affordable, appropriately scaled, and easy to operate and maintain. They can be equipped with a wide range of implements, including a PTO-driven rear-tine rotary tiller. Other implements that can be pulled or powered by a walk-behind tractor include mowers, hillers, rotary plows, seeders, and harvesters.



Tanya Srolovitz of Bloomfield Farm in Charlotte, Vermont, using a walk-behind tractor with a rototiller attachment. Photo: Andy Pressman, NCAT

Soil Preparation

Preparing the soil for seeding and planting crops is a multistep process. Depending on the soil condition and the kinds of crops to be planted, farmers can decide which tool or piece of equipment to use, the depth to which the soil needs to be prepared, and when the soil should be worked. Soil preparation disrupts soil structure and soil life. Maintaining and enhancing the life of the soil is the farmer's responsibility, and it depends on the farmer's ability to select and use the right tools and practices to prepare the soil for crop production. In some instances, farmers can get exceptional crop quality and yields with minimal soil disturbance through such practices as no-till farming or preparing raised garden beds through the technique of double-digging, in which the soil is loosened to a depth of 24 inches.

Breaking the soil for commercial crop production usually requires the art of plowing or tilling the soil. The goal of soil preparation is to minimize soil damage while creating a smooth, deeply loosened seed bed with as little residue and as few weed seeds as possible in the top three to six inches. The tools loosen and aerate the soil, break up residues and weeds, and incorporate organic matter and soil amendments. A well-prepared bed will be easy to seed or transplant into, have good water drainage, and be easy to cultivate. Soil amendments and organic matter can be incorporated into the soil as it is being prepared for seeding or planting.

Hand Tools for Soil Preparation

Hand tools can thoroughly prepare a small amount of land for planting. Spades and digging forks are designed to thrust vertically into the soil rather than at an angle. They are preferable to a shovel because the blade of a shovel is often shorter than the blade of a spade; in addition, the curve of a shovel blade makes it difficult to deeply penetrate the soil. Short-handled spades and forks with a D- or T-shaped handle allow for more efficient use of energy when digging deeply and when moving soil.



A digging fork (left) with a T-handle and a spade with a D-handle. Photo: Andy Pressman, NCAT

After the soil has been forked or spaded, a garden rake can be used to break up larger clods and remove residues and stones that, left alone, could interfere with planting, cultivation, and overall plant health. Rakes can also be used to level a bed and open furrows for seeding. They can be used with the head facing either up or down and by using a push-pull motion. The handle of a rake can also be held parallel to the body so that the head can be used to lightly tamp down the soil after seeding. The seedbed rake is designed with longer tines that can be covered with tubing to mark out specific rows for planting.

The broadfork, or U-bar, is a 2-foot-wide spading fork used for deep tillage. It consists of two handles, one on each side of the fork, and teeth that are spaced about four inches apart. The teeth are designed and spaced so that as the handles of the broadfork are pulled down, the tines

break the soil and lift it without the broadfork itself being lifted. Once the soil is loosened, the broadfork is moved back about six inches, and the procedure is repeated down the bed. Many farmers find the broadfork useful for harvesting crops such as scallions and potatoes as well.

Equipment for Soil Preparation

Selecting the right piece of equipment for tillage depends on the type of soil that is desired. Tillage can be broken down into two kinds: primary and secondary. Primary tillage aggressively loosens the soil and breaks up residues at a depth of as much as two feet. Secondary tillage pulverizes and smooths the top several inches of soil. Equipment should be selected based on the type of tillage desired and how the equipment works given the specific characteristics of the soil. The tools' ability to perform correctly also depends on the horsepower of the tractor. Soils that are heavy, compacted, or have significant amounts of residues, for example, may require greater horsepower.

Primary Tillage Equipment

Primary tilling is performed by different types of plows, discs, rototillers, and spading machines. The moldboard plow is one of the oldest implements used for soil preparation; it consists of one or more curved pieces of metal, called bottoms, attached to a frame. The bottoms are pulled through the soil to cut and then invert, either partially or wholly, the soil. One- to 4-bottom plows are common for small-scale production, and each bottom requires approximately 10 to 15 horsepower from the tractor. Plows come in various shapes and sizes, which determine the depth of the plow and how it moves the soil. Disc coulters can be added to the front of the plow to cut the soil so that the bottom penetrates the soil more effectively.

Chisel plows, or field cultivators, have curved shanks (also known as chisels) with sweeps or other tips attached to them. They are used for loosening the soil without inverting it, thus leaving residues on the soil surface. They are often used to break up hardpans and heavy soils and can be run across a bed before planting root crops. Root penetration can also be improved with a subsoiler. Subsoilers have straighter and longer shanks than chisel plows, usually about

18 inches; each shank needs about 25 horsepower to penetrate 18 inches or so. Subsoilers are also used to break up compacted soils and improve drainage and aeration by penetrating deeper than a chisel plow into the soil.

Discs can be used for both primary and secondary tillage. Discs are ground-driven implements that cut and mix the soil. They come in several different shapes and sizes and can be arranged in different rows and at different angles. Discs perform best on soils that don't have a lot of residue and on soils that are not so wet that they will clog or so dry that they don't cut. Heavy discs can be used for primary tillage, and adding additional weight to the disc can help it cut farther and incorporate better. Lighter discs can be used for secondary tillage after the soil has been plowed.

Rotary tillers also can be used for primary and secondary tillage up to eight inches deep. Rotary tillers are instrumental in small-scale vegetable production because they have the ability to produce fine seedbeds at varying widths. They are suitable to use with walk-behind tractors that have as little as 5 horsepower and ridden tractors of up to 100 horsepower. Rotary tillers have a rotating shaft with several attached tines that mix the soil at various depths. While most tillers on the market use a forward rotation to mix the soil, newer reverse-tine tillers use reverse action to pull the tiller into the ground by burying larger soil clods underneath smaller clods, often leaving a finer seedbed with less compaction.

Rototilling is an effective way to prepare a seedbed; however, there are serious drawbacks when the tool is overused. Continuous rototilling can create a hard layer of soil, or plow pan, underneath the tilled soil and increase organic matter decomposition. It can also create soils that quickly erode. Reducing the rototiller's revolutions per minute or increasing the tractor's ground speed can be less harmful to the soil than normal rototilling (Wiswall, 2009).

Spading machines are an alternative to using a rotary tiller. Common in Europe, spading machines loosen the soil and incorporate residues without turning the soil. Spaders are either rotary or reciprocating, and the spades on both types move more slowly than a rotary tiller through the soil. This action works the soil more effectively without causing compaction. Depending on the condition of the soil, a fine

seedbed can be accomplished in a single pass without secondary tillage.



A Celli spading machine at Pennypack Farm and Education Center in Horsham, Pennsylvania. Photo: Andy Pressman, NCAT

Secondary Tillage Equipment

Depending on how rough or crusted the soil is and how much plant residue remains, using secondary tillage equipment can further refine and level the soil before seeding or planting. Harrowing is used for shallow tillage and is most commonly practiced after plowing. Harrows can be used to break down the furrow slices caused by the plow, reduce clods, smooth out the soil surface, and kill young weeds. The types of harrows include light disc harrows, chain-link harrows, spring-tooth harrows, and spike-tooth harrows. If sod has been plowed under, the disc harrow will not bring lumps of sod up to the soil surface—unlike the spring-tooth or spike-tooth harrow. Although spike-tooth harrows do not pulverize the soil as well as other types of harrows, they can sometimes be used to cover broadcast seed.

Field cultivators consist of a toolbar with different implements mounted on it. They are heavier than harrows and are used when the soil is too rough, is too compacted, or has too much residue for a harrow. The toolbar usually has C-shanks or S-shanks with sweeps, tines, chains, or rollers attached to the bottom.

Bed Shaping

There are several advantages to forming raised beds, including warmer soils and better drainage. In addition, raised beds make it easier to steer a tractor and implement for planting and cultivating. Bed shaping is usually done by

Continuous rototilling can create a hard layer of soil, or plow pan, underneath the tilled soil and increase organic matter decomposition. It can also create soils that quickly erode.

pushing loose soil into ridges with a hilling disc or other implement and then forming and pressing the soil into a bed. There are many different styles of bed shapers. Some can lay drip tape and plastic mulch and apply fertilizers; many designs are made right on the farm.

Seeding and Planting

Farmers must take several factors into consideration when choosing how best to establish a crop for production. Local soil and growing conditions, market considerations, and production resources affect whether a crop should be direct seeded or transplanted. How a crop is planted will affect its performance in establishment, earliness, quality, and yield.

Equipment for Direct Seeding

Direct seeding requires contact between the seed and the soil so that the crop can establish itself once it germinates. Spin seeders are used for broadcasting cover-crop seeds at a set desired rate. They can be handheld or tractor mounted. Light harrowing, raking, irrigating, or adequate rainfall will help ensure good seed-to-soil contact.

Other types of seeders should be used for crops that need to be planted in the soil at a uniform spacing and depth. These include precision seeders, pinpoint seeders, stick- or jab-type seeders, and drills. Precision seeders can be manually pushed or tractor mounted and dispense individual seeds in a furrow. Seeds can be singulated through several different mechanisms, including cups, belts, vacuums, plates, and rollers. For small-scale farms, Glaser, Earthway, and Jang

are brand names of precision push seeders that use plates or rollers. The Stanhay uses belts, and the Nibex uses cups—both are available as walk-behind push seeders or toolbar-mounted seeders (Volk, 2009). Many of these single-row seeders offer attachments that can connect seeders together for seeding multiple rows, attach seeders to a wheel hoe, or mount seeders with a fertilizer attachment.

Pinpoint seeders are designed to be manually pulled and perform well for greenhouse planting. Medium- to large-sized seeds can be hand planted through a stick- or jab-type seeder that can also plant through plastic mulch. Seed drills also are available for manual or tractor-mounted seeding. Discs can be set for the size of the seed, but thinning may be necessary to achieve proper spacing between plants. Planet Jr. is a classic name associated with vegetable drills. Drills can also be used for planting grains and cover crops.

Desirable Features of a Hand-Pushed Precision Seeder

In his book *The New Organic Grower*, Eliot Coleman suggests a number of characteristics to look for in a hand-pushed precision seeder:

- It is easy to push in a straight line
- It gives precise seed placement
- It allows accurate depth adjustments
- It is easy to fill and empty
- It is flexible and adaptable
- It has a visible seed level and seed drop
- It includes a dependable row marker

Equipment for Transplanting

Setting out transplants helps to extend the growing season and harvest. Many farmers transplant crops by hand using a trowel, a dibbler, or a jab-style planter, but mechanical transplanters can speed up the planting process with more accuracy and less labor. Mechanical transplanters require one person to drive the tractor while a crew of one or more people drops transplants into the soil. Many farmers have designed simple sled-type transplanters that allow the crew to sit or lie down while they transplant by hand. Commercial transplanters have a shoe, coulter, or some other device to open the planting furrow. They also have a closing wheel that packs



SPIN farmer Wally Satzewich of Wally's Urban Market Garden in Saskatoon, Saskatchewan, using an Earthway seeder. Photo: Courtesy of SPIN-Farming

the seedlings, which are held on trays, in place once they are planted. Water-wheel transplanters inject water into the hole after the plant is set. Other types of transplanters include the gripper type, the carousel, the spade type, and the no-till transplanter.



A Rainflo water-wheel transplanter at Pennypack Farm and Education Center in Horsham, Pennsylvania. Photo: Andy Pressman, NCAT

Weed Control

Weeds compete with crops for light, water, and nutrients, and they can affect a farm's economic bottom line. Weeds can reduce crop yields through competition with cash crops, promote pests and disease, and even be problematic in the harvesting process. As a result, there is a large cost associated with controlling weeds. Minimizing weed growth both in the short term and the long term should be considered when designing a cropping system. Careful planning to limit weeds' competition with cash crops and to reduce the amount of time, fuel, and other resources spent on controlling weeds can be vital to a farm's economic viability.

There are several techniques for effectively controlling weeds, including chemical and cultural

A weed-management strategy includes a number of factors:

- Timing weed control-operations
- Selecting the most appropriate tools for cultivating
- Forming planting beds and crop-row spacing to match the cultivation tool and its configuration
- Incorporating other cropping practices such as cover crops, crop rotation, irrigation, fertilization, and pest management

approaches, as well as the use of cultivation tools. Many of the control techniques can be integrated together to be more effective. All of the techniques are focused on either preventing weed seeds from germinating (pre-emergence) or suppressing established weeds (post-emergence).

Cultural Practices

Cultural practices utilizing equipment include cover cropping, the use of stale seedbeds, mulching with both organic and inorganic materials, and mowing. The practice of using a stale seedbed targets weed seeds within the top one to two inches of soil and is usually performed mid to late season. This technique allows for the weed seeds to germinate, but the young weeds are then killed through such practices as flaming or scraping just below the soil surface. This prevents new seeds from coming up to the surface. Mowing weeds can stress the weed plants so that they are unable to flower and set viable seed. Mowing around crops also can limit weeds' ability to compete.

Mulching can create a physical barrier to limit weed growth. Organic mulches such as straw can also reduce the soil temperature, which may slow down the growth of weeds. Plastic mulches are used with heat-loving plants and promote an earlier harvest by raising the soil temperature. Plastic mulches come in a variety of colors that affect the soil temperature differently. Although black plastic mulch doesn't provide much heat to the soil, it effectively suppresses weeds. A plastic-mulch layer is an implement that can quickly lay plastic in a straight, flat, and tight manner over a bed. Depending on the unit, plastic-mulch layers can level the soil surface, shape beds, lay plastic over hoops or raised beds, and even lay drip tape under the mulch, all in one pass. Plastic-mulch lifters can be used to assist in pulling up the plastic mulch at the end of each season.

Cover crops can be planted to suppress weeds. Cover crops such as rye, oats, buckwheat, and sorghum-Sudan grass can be planted during certain times of the year in order to smother out weeds through competition or by creating a mulch layer. Some crops, such as rye, contain allelopathic chemicals that prevent weed seeds from germinating. The roller-crimper is a cutting-edge implement that is being used in no-till planting. It consists of a metal drum with protruding blunt metal blades arranged in a pattern

designed to roll over a cover crop and crimp the plants so that they die, creating a mulch layer. Crops can then be planted or transplanted directly through the mulch.

Hand Tool Cultivation

The primary tool used in hand cultivation is the hoe. For many farmers, hoeing may seem like back-breaking and labor-intensive work. This may well be the case, especially when using the standard hoe with a 90-degree angled blade and a 54- to 57- inch handle for weeding. These hoes are designed for such tasks as digging, chopping, and hilling soil, and they are inadequate for cultivating smaller weeds that have germinated in intensively planted beds. Understanding when to hoe and how to use different hoes will allow for easy cultivation of weeds.

The eye-hoe, or chopping hoe, is one of the oldest and most traditional tools in the world. The eye-hoe is designed with a heavy head for chopping larger weeds and roots and for moving soil. They are swung similarly to an axe, with the weight of the head doing the work.

Upright hoes allow for smaller weeds to be sliced just below the soil surface. Their blades can fit in narrow spaces and are relatively lightweight. The handles tend to be longer, between 66 and 74 inches, which allows for a farther reach and for hand positioning that allows the user's back to stay straight. Examples of upright hoes are

the narrow collinear hoe, the swan-neck or half-moon hoe, the push hoe, the diamond hoe, and the stirrup hoe, which is also known as the oscillating or hula-hoe.

The narrow collinear hoe has a thin metal blade, usually 3¾-inches or 7-inches long, placed at a 70-degree angle to the handle. The blade runs parallel to the soil surface and is used in a pulling motion with the user standing sideways. The swan-neck hoe also is used in a pulling or sweeping motion, and the blade is a bit heavier and wider than the blade of the collinear hoe. The push hoe is designed with the front of the blade sharpened and lies flat on the ground so that it can “scuffle” across the soil surface in a pushing motion. The diamond hoe is sharpened on both the front and back of the blade, allowing it to cut in both a pushing and a pulling motion. The blade of a stirrup hoe is not fixed like the diamond hoe's, which allows it to dig deeper into the soil as it cuts in both directions. In addition, the stirrups, or sides of the blade, make it possible for users to see how close they are cutting to the cash crop.



From left to right, a collinear hoe, a swan-neck hoe, a stirrup hoe, a “regular” hoe, and an eye-hoe. Photo: Andy Pressman, NCAT



The author, standing straight and holding the handle with thumbs pointing up, is demonstrating the correct position for using a long-neck hoe. Photo: Andy Pressman, NCAT

Wheel hoes are one of the most efficient tools for weed cultivation on small land bases. The ability to attach different cultivation implements, such as stirrup hoes, chisels, and sweeps, onto a wheeled frame allows the user to stay upright while pushing and pulling the tool at a decent speed. Wheel hoes have either one or two wheels. Although the double-wheeled version is less common, it allows for cultivation on both sides of a crop row at the same time. Wheels come in different diameters, usually from nine to 24 inches, with the smaller-wheeled models being easier to direct and less tiring and cumbersome to use (Coleman, 1995).



The author using a single-wheel hoe with a stirrup attachment. Photo: Andy Pressman, NCAT

Huguenot Street Farm in New Paltz, New York, received funding from the USDA-SARE program to develop detailed instructions on converting an Allis Chalmers Model G into an electric vehicle. The instructions are available online at: www.flyingbeet.com.



An Allis Chalmers G converted to electric at Fair Share Farm, Kearney, Missouri. Photo: Rex Dufour, NCAT

Mechanical Cultivation

For many farms, an increase in production efficiency begins with a cultivating tractor. Farmall, Allis Chalmers, Ford, Case, Oliver, Kubota, and John Deere are some common brand names of cultivating tractors, and many models are designed for accuracy by allowing the driver to steer closer to the crops while cultivating. Guidance accuracy was incorporated into the design of many models through the use of belly-mounted toolbars and by offsetting the motor to give the driver a clear line of sight. Having the toolbar belly mounted also compensates for the lateral direction of the toolbar while steering. In other words, the toolbar moves slightly in the same direction the tractor is being steered. With rear-mounted implements, on the other hand, the toolbar moves slightly in the opposite direction of the tractor as it turns.

Many cultivating tractors were manufactured during the late 1940s and early 1950s and are still common on small-scale vegetable farms. The Allis Chalmers Model G, for example, was built between 1948 and 1955, and, unlike other cultivating tractors, its motor was placed behind the driver to provide even further guidance when cultivating. While some cultivating tractors were designed to be low to the ground for precision cultivation between young or low-growing crops, other tractors, such as the Landini, were built with a high clearance to cultivate between larger crops throughout the growing season.

There is a broad range of tractor-drawn and PTO-driven implements for weed cultivation. In addition to reducing weed populations and the use of herbicides, many of the implements function to loosen, aerate, and till the soil, as well as incorporate fertilizers into it. Implements for cultivation are designed for both post- and pre-emerging weeds and include sweeps, discs, torsion hoes, brush hoes, spider wheels, finger weeders, S-tines, basket weeders, rolling cultivators, and other specialized cultivating devices. Some of the more common implements are described below. For a detailed explanation of weed-management tools, see “Steel in the Field” in the Further Resources section.

Cultivation Equipment for Pre-Emergence Weed Control

Controlling weeds before they germinate involves cultivating just below the soil surface. Pre-emergence cultivation can be done prior to or in between plantings or shortly after a crop has been planted. “Clean fallow” is a term used to describe the repeated cultivation before or in between plantings and is used to kill annual weeds, reduce weed-seed banks in the soil, and remove perennial weed growth (Grubinger, 1999). Once a crop has been planted, and even germinated, a technique known as blind cultivation is used in and between rows. Blind cultivation targets small weeds that have been up for a week or less and does not prevent large-seeded crops that have been sown deeply from germinating.

Disc harrows are one of the most versatile cultivation tools for clean fallowing. The blades of the disc loosen and mix the soil through a lifting action, which then leaves the soil level. Tandem disc blades are usually 16 to 18 inches in diameter and are set about seven inches apart, while offset disc harrows have discs 20 to 24 inches in diameter and are set nine inches apart (Schwenke, 1991). Offset disc harrows are often used in orchards because they can be set up to stir the soil close to trees. Some perennial weeds, particularly those that spread through rhizomes, are better dealt with by equipment that can dig the rhizomes up to the soil surface, where they can dry out and die. Spring-tooth harrows or field cultivators equipped with sweeps or shovels work well for uprooting perennial weeds.

Tine weeders and rotary hoes are two implements commonly used for blind cultivation. Tine weeders, also known as flex-tine weeders, consist of many small metal tines that are pulled through the soil at a fast speed, causing the tines to vibrate and remove the weeds from the soil. Timing is key because the tines scratch the cash crop as well as the weeds growing in between the rows. The depth of the tines can be controlled by gauge wheels or by using a 3-point hitch. Rotary hoes often are used for blind cultivation in corn and beans and for breaking up the surface of crusted soils (Grubinger, 1999). Rotary hoes are ground driven and consist of several spider wheels with “spoons” or tips that rotate and remove weeds.

Cultivation Equipment for Post-Emergence Weed Control

Tools for post-emergent weed cultivation are designed to be used for specific crop stages. As a crop grows and gains strength, more aggressive tools that throw soil can be used, such as sweeps, basket weeders, Spydors™, hilling discs, finger weeders, row-crop cultivators, and rolling cultivators. Implements such as wiggle hoes and brush weeders are designed for cultivating smaller crops between rows.

The sweep is one of the most basic tools used for cultivation. Sweeps are V-shaped blades that attach to a shank that is attached to a toolbar. Depending on the style of sweep, the blade faces forward and slices, drags, or buries the weeds while throwing soil into the rows. The toolbar can be rear mounted, front mounted, or belly

mounted to the tractor. Sweeps are usually set to a depth of one inch below the soil surface, and the depth of the sweeps can be adjusted to accommodate for differences in elevation within a bed. Running a sweep too deeply can disturb plant roots and throw more soil. However, sweeps set at a deeper depth can also be used for hilling-up such crops as Irish potatoes, sweet corn, and broccoli (Schonbeck, 2010). Shovels are narrower than sweeps and throw less soil.



A basket weeder belly mounted to an Allis Chalmers G at Pennypack Farm and Education Center in Horsham, Pennsylvania. Photo: Andy Pressman, NCAT

Basket weeders consist of two rows of metal baskets that roll across the soil surface at different speeds. The first row is ground driven, which also drives a chain to power the rotation of the second row. This increases the rotation speed of the baskets in the second row so that they cultivate weeds that survive the cultivation of the first-row baskets. The baskets scuff the soil surface without moving the soil. Basket weeders are belly mounted, can be driven at moderate speeds, and are ideal for cultivating various greens such as lettuce. Budding basket weeders are designed for cultivating two- to eight-row beds.

The Spider™ is a ground-driven wheel with offset teeth angled to either throw soil toward or away from the row. Torsion weeders and spring-hoes can be mounted to the Spider™ to take care of weeds missed by the teeth of the Spider™.

Hilling discs are used to pull soil away from small crops or to hill (throw soil toward) larger crops, such as potatoes and sweet corn.

Finger weeders are metal cone-shaped wheels mounted to the belly of a tractor. Protruding from the wheels are rubber-coated metal fingers that cultivate around the stems of plants. The wheels are ground driven and cultivate closely in rows.

Rolling cultivators contain gangs of wheels with tines angled to either throw or hill soil into the rows. The gangs swivel as they slice through the soil digging up weeds. A fertilizer attachment can be used at the same time as a rolling cultivator for side-dressing crops (Grubinger, 1999).

A row-crop cultivator is a metal frame with several attached shanks and cultivators. The shanks can be set for specific crop rows and throw the soil as the frame is pulled by a tractor. Shields can be mounted to protect the more delicate plants.

Wiggle hoes are steered from the back of the implement as it is pulled by a tractor. They consist of half sweeps that face either to the left or the right and are attached to a shank. Wiggle hoes can be steered by the driver close to the crops but require wide crop spacing.

The European brush weeder sweeps weeds out of the soil. The brushes fit between narrow rows of crops, which are protected by a shield. As with the wiggle hoe, a brush weeder is steered from the back of the implement by a driver.

Flame weeders use propane burners that create a flame of intense heat to control small weeds. Flame weeding is often used to kill weeds in the stale-seedbed technique, particularly for intensive plantings of greens and herbs, because it does not disrupt or throw the soil. There are different scales of flame weeders, from handheld or backpack flamers to tractor-mounted implements. The ATTRA publication *Flame Weeding for Vegetable Crops* has additional information on the use of flame weeders.

Foggy Meadow Farm – Benson, Vermont

Paul Horton and Sally Beckwith of Foggy Meadow Farm produce naturally grown vegetables and herbs on 4½ acres in Benson, Vermont. Foggy Meadow is a year-round operation that direct markets its crops through farmers markets and restaurants. From its start in 2004, Foggy Meadow has invested in small-scale equipment and tools, which has resulted in the farm being able to continue producing at this scale and remain economically viable.

Horton and Beckwith believe every farm should develop a reputation for growing certain crops; Foggy Meadow is known for its high-quality greens and carrots. Although most crops on the farm are transplanted, the farmers at Foggy Meadow direct seed 1,000 row feet of salad mix and 10,000 row feet of carrots each week from March through September to ensure a continuous supply. Greens are grown in two 15-foot by 96-foot high tunnels during the spring and winter months, and tomatoes take root in them during the summer. The high tunnels are moved once or twice a year to new soil to help protect plants from soil salinity issues, pests, and disease.

Field crops are grown in ¾-acre sections. This amounts to having six to seven sections, which allows Horton and Beckwith to plan for extensive crop rotations. As spring crops come out of the ground, some land becomes a stale seedbed while other parcels are cover cropped or sheet mulched for use the following spring.

The farm uses a 70-horsepower John Deere tractor for field tillage and bed preparation. Beds are prepared for planting with a combination of a 5-shank chisel plow and a 70-inch rototiller. This creates beds for up to three crop rows, which are marked out in the bed by using pins on a basket weeder. The Buddingh basket weeder is attached to a Farmall Cub—one of four tractors used for cultivation. There are two Farmall Super Cs, one with sweeps and hilling discs and the other with shovels that are matched with the rows in each bed. In addition, a Farmall A tractor is set up with a 6-foot disc and harrow for planting cover crops. Having tractors set up with only one implement reduces the time and stress involved with switching implements on a single tractor. As Foggy Meadow Farm looks to produce more crops for winter markets, Horton is interested in purchasing another cultivating tractor with a toolbar set up for single-row crops.



Foggy Meadow Farm, Benson, Vermont. Photo: Courtesy of Sally Beckwith

Summary

Choosing the right tool or piece of equipment can be a challenge, but it can greatly affect production efficiency and the economic bottom line for the small-scale farmer. Investing in well-designed hand tools of good quality enhances the farmer's ability to maximize production on an intensive scale. Using tractors and implements designed for small-scale intensive crop production can increase crop quality and yields while reducing labor inputs. Such factors as soil type and crop selection play an important role in the utilization of farm equipment.

References

- Coleman, Eliot. 1995. *The New Organic Grower*. Chelsea Green Publishing, White River Junction, VT.
- Grubinger, Vernon. 1999. *Sustainable Vegetable Production from Start-Up to Market*. Natural Resource, Agriculture, and Engineering Service, Ithaca, NY.
- Kains, M.G. 1973. *Five Acres and Independence: A Handbook for Small Farm Management*. Dover Publications, Inc., New York, NY.
- Hendrickson, John. 2005. *Grower to Grower: Creating a Livelihood on a Fresh Market Vegetable Farm*. Center for Integrated Agricultural Systems. University of Wisconsin, Madison, WI.
- Schonbeck, Mark. 2010. *Design the Cropping System and Select Tools for Effective Weed Control*. eXtension. www.extension.org/pages/18531/design-the-cropping-system-and-select-tools-for-effective-weed-control
- Schwenke, Karl. 1991. *Successful Small-Scale Farming: An Organic Approach*. Storey Publishing, North Adams, MA.
- Village Earth. 2011. *Agricultural Tools*. Fort Collins, CO. www.villageearth.org/appropriate-technology/appropriate-technology-sourcebook/agricultural-tools
- Volk, Josh. 2009. *Tools that Make Direct Seeding Easier*. Growing for Market. www.growingformarket.com/articles/20090428_6
- Wiswall, Richard. 2009. *The Organic Farmer's Business Handbook*. Chelsea Green Publishing, White River Junction, VT.

Further Resources

Books

Steel in the Field – A Farmer's Guide to Weed Management Tools. 1997. Edited by Greg Bowman. A publication of the Sustainable Agriculture Network (SAN), Beltsville, MD.

Organizations

The Core Historical Literature of Agriculture (CHLA)
<http://chla.library.cornell.edu>

Cornell University's electronic collection of more than 1,800 agricultural texts published between the early 19th century and the middle to late 20th century. CHLA contains numerous titles on farm equipment, many of which provide illustrations and descriptive uses of tillage, cultivation, and soil-preparation equipment.

eXtension

www.extension.org

Extensive information from land-grant universities on agriculture, including articles and videos on organic soil and weed management.

Growing for Market

P.O. Box 3474

Lawrence, KS 66046

800-307-8949

www.growingformarket.com

Subscription journal with news, advice, and resources for market farmers. Articles are written by market farmers and regularly include information on equipment and tools for market farms.

The Healthy Farmers, Healthy Profits Project

<http://bse.wisc.edu/hfhp/index4.htm>

Tip sheets on small farm tools and equipment from a team of researchers and outreach specialists that finds and shares work-efficiency methods to improve health, safety, and profits for nursery growers, berry and fresh-market vegetable farmers, and dairy producers.

NCAT Small-Scale Intensive Farm Training (SIFT)

Program

<http://sift.ncat.org>

This new program is providing in-depth, hands-on training to local food producers who will learn how to commercially produce a large amount of high-value, nutrient-rich food on small parcels of land in a sustainable and environmentally responsible manner.

Rodale Institute

611 Siegfriedale Road

Kutztown, PA 19530

610-683-1400

www.rodaleinstitute.org

Organization dedicated to researching and promoting organic farming practices. It produces extensive information on organic crop production, including no-till farming and the use of the roller-crimper.

Village Earth

P.O. Box 797
Fort Collins, CO 80522
970-237-3002
info@villageearth.org
http://villageearth.org

Extensive information on appropriate technologies from a network of organizations and people who work to support marginalized communities around the world.

Yesterday's Tractor Company

www.ytmag.com

Website with active forums, photos, and extensive information about pre-1985 farm equipment.

Videos

Vegetable Farmers and Their Sustainable Tillage Practices. Created by Vern Grubinger of University of Vermont Extension.

Center for Sustainable Agriculture
University of Vermont
106 High Point Center, Suite 300
Colchester, VT 05446-8800
802-656-5459
sustainable.agriculture@uvm.edu
www.uvm.edu/sustainableagriculture

Vegetable Farmers and Their Weed Control Machines.

Created by Vern Grubinger of University of Vermont Extension and Mary Jane Else of University of Massachusetts Extension.

Center for Sustainable Agriculture
University of Vermont
106 High Point Center, Suite 300
Colchester, VT 05446-8800
802-656-5459
sustainable.agriculture@uvm.edu
www.uvm.edu/sustainableagriculture

Suppliers

A.M. Leonard, Inc.

241 Fox Drive
Piqua, OH 45356
800-543-8955
info@amleo.com
www.amleo.com

Offers quality horticulture tools and equipment for nursery, landscape, and agriculture customers.

Bountiful Gardens

18001 Shafer Ranch Road
Willits, CA 95490
707-459-6410
bountiful@sonic.net
www.bountifulgardens.org

Supplier of durable hand tools from England.

Earth Tools

1525 Kays Branch Road
Owenton, KY 40359
502-484-3988
www.earthtoolsbcs.com

Offers BCS and Grillo walking tractors, compatible implements, and a full line of hand-forged and professional garden tools.

Elomestari Ltd.

Koskitie 185
FIN-45520 Kukkola
Tornio, Finland
+358 16-472 000
Petri.leinonen@elomestari.fi
www.elomestari.fi/english/english.htm

Finnish company specializing in products for small-scale sustainable farming. The company is the maker of the Weed Master (a manual carrier for seeding, planting, flaming, spraying, and hoeing) and the Crawler (a motorized lay-down working cart for all horticultural work).

Ferrari Tractor C.I.E.

P.O. Box 1045
Gridley, CA 95948
530-846-6401
sales@ferrari-tractors.com
www.ferrari-tractors.com

Dealer of new and used equipment for the small farm, with expertise in carrying European-made 2- and 4-wheel compact tractors and implements.

Green Heron Tools

P.O. Box 71
New Tripoli, PA 18066
610-844-5232
info@greenherontools.com
www.greenherontools.com

Maker of high-quality hand tools and equipment specifically designed for women farmers.

Gulland Forge Broadfork

502-682-8529

gullandbroadfork@me.com

<http://gullandforge.com>

Online business offering a high-quality forged broadfork.

Harmony Farm Supply and Nursery

P.O. Box 460

Graton, CA 95444

707-823-9125

info@harmonyfarm.com

www.harmonyfarm.com

Offers a full range of tools and supplies for the small-scale farm.

Hida Tool & Hardware Company, Inc.

1333 San Pablo Avenue

Berkeley, CA 94702

800-443-5512

hidatool@hidatool.com

<http://hidatool.com>

Specializes in Japanese handcrafted weeders, hoes, sickles, and cutting implements.

Johnny's Selected Seeds

955 Benton Avenue

Winslow, ME 04901

877-564-6697

communications@johnnyseeds.com

www.johnnyseeds.com

Offers a complete line of tools for the gardener or commercial grower, including flame weeders, wheel hoes, seeders, and hand tools.

Lee Valley Tools

P.O. Box 1780

Ogdensburg, NY 13669

800-267-8735

customerservice@leevalley.com

www.leevalley.com

Offers an extensive inventory of gardening tools and implements.

Market Farm Implement

257 Fawn Hollow Road

Friedens, PA 15541

814-443-1931

www.marketfarm.com

Specializes in vegetable-crop machinery from tillage to harvest.

Mechanical Transplanter Company

1150 Central Avenue

Holland, MI 49423

800-757-5268

mtc@mechanicaltransplanter.com

www.mechanicaltransplanter.com

Offers a full range of manual and tractor-mounted equipment for tillage, planting, and cultivation.

Organic Growers Supply (FEDCO)

P.O. Box 520

Waterville, ME 04903

207-873-7333

www.fedcoseeds.com

Cooperative supplier of hand tools, orchard supplies, irrigation, and seed-starting supplies for the organic grower.

Peaceful Valley Farm and Garden Supply

125 Clydesdale Court

Grass Valley, CA

888-784-1722

helpdesk@groworganic.com

www.groworganic.com

Offers a full line of hand tools; growing supplies; irrigation and season-extension supplies; organic soil amendments; seed; and pest and weed controls.

Purple Mountain Organics

7120 Carroll Avenue

Tacoma Park, MD 20912

877-538-9901

<http://purplemountainorganics.com>

Offers a full line of high-quality tools and equipment for the small farm, including hand tools, walking tractors, compact tractors, and implements.

Red Pig Tools

12040 SE Revenue Road

Boring, OR 97009

503-663-9404

redpigtools@frontier.com

www.redpigtools.com

Maker of forged-steel hand tools, including left-handed tools.

Rogue Hoe

4360 Bado Road

Cabool, MO 65689

417-962-5091

sales@roguehoe.com

www.roguehoe.com

Maker of hand-crafted hoes made from recycled agricultural disc blades that are sharpened on three sides.

Seeds of Change

P.O. Box 4908
Rancho Dominguez, CA 90220
888-762-7333
www.seedsofchange.com

Offers seeds, digging and cultivating tools, hand tools, rakes and hoes, and seed-saving supplies.

Small Farm Innovations

3701 State Highway 36, South
Caldwell, TX 77836
979-200-1473
smallfarminnovations@hughes.net
www.smallfarminnovations.com

Supplier of compact tractors and farm implements for small acreages, including compact hay equipment.

Valley Oak Tool Company

P.O. Box 301
Chico, CA 95926
530-342-6188
david@valleyoaktool.com
www.valleyoaktools.com

Specializes in high-quality wheel hoes and broadforks.

Notes

Equipment and Tools for Small-Scale Intensive Crop Production

By Andy Pressman

NCAT Sustainable Agriculture Specialist

Published September 2011

© NCAT

Rich Myers, Editor

Robyn Metzger, Production

This publication is available on the Web at:

www.attra.ncat.org

IP417

Slot 411

Version 092011

Tractor Primer for the Market Farm

Wisconsin School for Beginning Market Growers

Much can be said for the small market garden that relies on hand labor and a sturdy rototiller. These market gardeners prove that it does not require a significant investment in tools to grow a good deal of vegetables (and generate significant gross sales) on an acre or less. Some growers even manage to cultivate two or three acres of vegetables without a tractor. A quality, heavy duty, rear-tine tiller can incorporate cover crops and even sod (with adequate weight and horsepower) and prepare a seedbed for direct seeded crops or setting transplants. However, this does require a good deal of time and can put undo wear and tear on the grower, the soil, and the tiller.

Rototilling can be overdone and have deleterious effects on soil structure, tilth, and soil biology. Some growers ameliorate these effects by extensive cover cropping, mulching, and finding neighboring farmers or retired farmers to perform disking, chisel plowing, or sub-soiling. This can be a very economical option, allowing the small-scale farmer to not buy and maintain larger-scale equipment. One challenge is that a neighboring farmer is most likely going to do plowing work on *their* schedule not the market grower's. This can mean lost planting opportunities and tilling the soil under less than ideal conditions. When it is time to till and plant on the market farm, a day delay (or even hours) can have significant impacts. Some growers rent a tractor and implements periodically to conduct primary tillage and handle large tasks. There comes a time for most growers, however, when—due to age, acreage or efficiency—the services of a tractor are most welcome to ease some of the hard manual labor and long hours involved in producing vegetables. Farming with horses is another viable option but will not be discussed here.

The following is meant to introduce some essential basics about tractors for the new and beginning grower who is ready to purchase a tractor. This is not meant to be a complete or detailed treatise. It is wise for growers to gather information from a variety of sources including neighboring farmers, other fresh market vegetable growers, books, reputable dealers, and elsewhere. Increasingly, there is information available on the Internet and such resources are listed in the reference section.

Tractor and implement advice can vary significantly depending on who is giving it. Most growers have their favorites and color bias (such as John Deere green or International red) when it comes to tractors! Given that advice is likely to vary, it is best to do plenty of research before making a purchase. This publication aims to provide a foundation in understanding basic terms and issues from a small farm perspective.

The remainder of this publication endeavors to provide some practical information and advice about tractors, including:

- Perspective on the number and type of tractors needed
- Recommended tractor features
- Advice on looking for and purchasing a used tractor
- Buying a new or grey market tractor
- Factoring in annual maintenance and repair costs
- Basic descriptions of various implements and their horsepower requirements
- Glossary of common terms and abbreviations

Tractors on the Market Farm

It is perhaps wise to first remind new growers that while a good tractor is invaluable, there are other equipment needs on a market farm. It is tempting to make a tractor the first major investment. After all, the tractor allows the grower to quickly and efficiently prepare soil for planting, pull a wide variety of implements, and, with a front-end loader, handle manure, compost or other heavy or bulky materials. Unless one chooses

to farm with horses, the tractor will be the central, crucial piece of equipment at the “front end” of the vegetable farm—along side the greenhouse for producing transplants. However, it is easy for many new growers to focus on tractors and tillage when developing and expanding a market farm, while neglecting to adequately capitalize the “back-end” of the farm in terms of walk-in coolers and post harvest handling facilities and equipment. Indeed, a walk-in cooler is, in most cases, a more important early purchase than a tractor. The successful small market farm most often relies on producing premium quality produce and adequate storage facilities are absolutely vital. Another important area to invest in is adequate irrigation. Of course, walk-in coolers and irrigation equipment are not nearly as fun as tractors! A walk-in cooler and irrigation are very likely to help you earn more money, however.

As mentioned above, it is possible to farm an acre or two without a tractor (or other form of horsepower) but this demands a great deal of manual labor. Even many one-acre market gardens utilize a garden tractor or other small utility (compact) tractor. Obviously, as scale increases the need for multiple tractors increases because there is more work to be done and more varied tasks. The book [How to Make \\$100,000 Farming 25 Acres](#) by Booker T. Whately (out of print) contains some practical advice on tractors for the diversified vegetable grower. Whately advocated a three-tractor vegetable growing system featuring a “big” tractor in the 40 to 50 horsepower range (small by modern farming standards), a secondary tractor in the 30-45 horsepower range, and a small cultivating tractor.

In this system, the big tractor handles primary tillage, manure handling, and helps with secondary tillage. The mid-sized tractor is a real workhorse, performing secondary tillage, seeding, transplanting, cultivation, and the operation of various specialty implements (potato harvesters, plastic mulch layers, etc.). The cultivating tractor, at 18-30 horsepower, is devoted to weed cultivation.

For farms less than 10 acres or for beginning operations, Whately suggests a two-tractor system consisting of the secondary, mid-sized tractor and the cultivating tractor. Primary tillage can still be accomplished using a slightly lower horsepower tractor or it might be contracted to a neighbor. At very small scales or for those just starting out, a one-tractor system would feature only the mid-sized tractor. A one-tractor farm is certainly viable; the biggest hazard is what happens when that tractor breaks down and there is no backup.

To update Whately's book, most vegetable growers growing 25 acres of vegetables today would likely recommend that the “large” primary tractor have perhaps 75 horsepower. Also, many vegetable growers above 15-20 acres appreciate having more than one cultivating tractor in order to leave specialized cultivating tools in place and ready to go. When the time is ripe for weed cultivation it pays to have equipment ready without time-consuming mounting and adjusting.

A tractor purchase can feel daunting but it is important to put the cost into perspective. Tractors can accomplish a multitude of tasks and should easily pay for themselves relatively quickly. As George DeVault writes for [New Farm](#): “A grower's time and the physical wellbeing are two of the most precious resources around a farm. What a tractor saves in time and physical—and emotional—wear and tear on (a) farmer is priceless.” Many growers advise others to “buy as much of a tractor as you can afford.” That said, a first tractor does not have to have all the bells and whistles. The next section discusses desired tractor features.

Recommended Tractor Features

Before buying a tractor, it is very wise to make a list of all the tasks you want the tractor to perform and the implements you anticipate using. To encourage thinking about future needs, make two lists: one of all the things you definitely plan to do with a tractor right away and a second list of things you might want to possibly add in the future. These lists will help determine the right size for your tractor in terms of horsepower as different types of equipment demand different levels of horsepower and traction. Table 1, at the end of this publication lists horsepower requirements for various implements. Another important fundamental decision that will influence tractor model options is your planting scheme. Although wheel width is adjustable on most

tractors, the width of your beds will impact which tractors are best suited to your farming system—or vice versa: the footprint of your existing or desired tractor may impact the width of your vegetable beds.

The two most basic and important features to look for are a three-point hitch and power take-off (PTO).¹ Without these, a tractor is very limited in what it can do. The three-point hitch allows you to mount a wide variety of implements securely and efficiently. While older implements may only require a draw bar, virtually all modern implements used in vegetable production are based on the three point hitch. The three point hitch became common on tractors in the 1940s and 50s but was not standardized until after 1960.

The standardization of the three-point hitch involved classifying hitches in a series of categories. Each category of three-point hitch is designed for a specific range of tractor horsepower. As seen in table 1, below, each progressive category accommodates heavier pins in the mounting hardware of the implements to be mounted on the tractor. In most cases, a small to medium sized market farm will use a tractor and implements with a category 2 three-point hitch. See the diagram and table below. A PTO (power take-off) is necessary to transfer mechanical power from the tractor to implements such as tillers and mowers.

Figure 1: Three-point Hitch and PTO Diagram

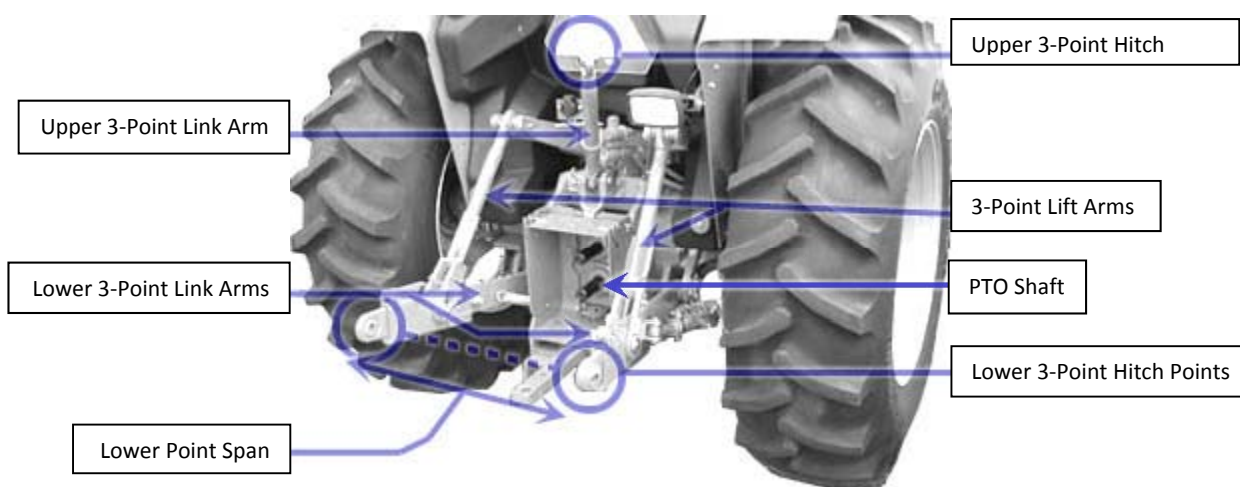


TABLE 1: Three Point Hitch Categories

Category	Hitch pin size		Lower hitch span	Tractor drawbar power
	Upper link	Lower links		
0	5/8 inch	5/8 inch	20 inches	Less than 20 hp
1	3/4 inch	7/8 inch	26 inches	20 to 45 hp
2	1 inch	1 and 1/8 inch	32 inches	40 to 100 hp
3	1 and 1/4 inch	1 and 7/16 inch	38 inches	80 to 225 hp
4	1 and 3/4 inch	2 inch	46 inches	180 to 400 hp

A wide front end is requisite on a vegetable farm in order to straddle crops and raised beds. Auction announcements and ads use the abbreviation WF to refer to tractors with the front wheels spaced so that they straddle a crop as opposed to narrow front (NF) or "tricycle" tractors that have the front wheel or wheels directly beneath the engine. Narrow front tractors are not only ill-suited to vegetable production but are dangerous as they are more prone to roll over accidents (more on safety issues and features below).

¹ See the glossary for an explanation of common tractor and implement names, terms, and abbreviations.

Other strongly desirable features include live hydraulics, low range or a creeper gear, and a front end loader. "Live" hydraulics refers to the ability to raise and lower implements when the clutch is engaged. A creeper gear permits driving the tractor at very low speeds, a useful feature when using a transplanter or certain types of tillage. Hydrostatic drive is another alternative that allows for very slow speeds. A front end loader is a bucket that can be raised and lowered and has many uses on the farm, most notably moving and handling compost, manure, gravel, or other heavy items. Power steering is very nice to have, especially for tractor operators with less upper body strength. Four wheel drive and hydrostatic drive are nice features indeed but can be pricey.² A four wheel drive tractor will boost the tractors traction and allow it to handle bigger tasks than a two wheel drive tractor of the same horsepower. A quick word of caution on four wheel drive tractors, however is that they can cause a great deal of damage to soils if used in wet soil conditions. Last but most importantly, safety features such as rollover protection (ROPS), PTO guards, and seatbelts are **strongly** recommended. ROPS became standard on newly manufactured tractors in 1985 so tractors built before then are unlikely to have this safety feature.

Looking for and Purchasing a Used Tractor

The first basic question to answer is whether you're going to buy new or used. There is also the important corollary: how used or how new? Tractors pre-dating 1940 are unlikely to have the horsepower and features to be satisfactory. An exception may be the common and relatively easy to find Ford 8n or 9n. These tractors have enough horsepower to pull two bottom plows and a variety of other small-scale implements and can be used effectively on 1-4 acre farm. They have their limitations, however, such as being quite low to the ground (thereby limiting their use and versatility on a diversified vegetable operation). They also will not have ROPS and other safety features.

One thing for beginners to note is that, unlike cars, a tractor's use and life is measured in hours, not miles. However, checking the hour meter is not like checking an odometer. What is considered heavy use in terms of hours depends in part on **what** the tractor was doing during those hours than the time itself. Tractors used extensively for front-end loader work are more likely to have more significant wear and tear. An even bigger factor is how the tractor was maintained over its hours of use. Depending on the farm, tractors may be used from 100 to 600 hours per year. The useful life of most tractors is generally around 12,000 hours, although this can vary substantially depending on how the tractor is used and maintained.

See Appendix A for a checklist of things to examine and consider when evaluating a used tractor.

When looking for a used tractor, be prepared to spend some time looking as it may take a while to find the right tractor in the right condition. One thing to keep in mind is the availability of parts and service. While there are some really neat looking older tractors around, if the manufacturer is no longer in business or is overseas, finding replacement parts and getting the tractor repaired may be difficult and expensive. It is best to stick with brands common and popular in your state or region.

There are generally three ways to buy a used tractor: at auctions, at dealerships, or classified ads. Generally, auctions may afford the opportunity for the best deals but finding the right tractor can be time consuming and requires the ability to quickly assess tractor condition and value. Newcomers to farming would be advised to find experienced friends and neighbors to help them evaluate tractors and make wise bids at auctions. Shopping via classified ads does not require traveling to auctions and, if you know what you are looking for, a wanted ad can be a good way to locate equipment. Buying from a known, reputable dealer may be the safest route because you can have assurance that the tractor that has been examined and serviced. Finally, there are a number of websites where one can locate used tractors and implements. See the Resource section.

² When considering the price of tractors and features one may want to consider Joel Salatin's advise in his book [You Can Farm](#): the price difference between a slightly larger, more powerful, or 2 versus 4-wheel drive tractors is not that high compared to the overall purchase price.

Grey Market Tractors

The grey market refers to the trade of a commodity through distribution channels which, while legal, are unofficial, unauthorized, or unintended by the original manufacturer. In general, grey market tractors are used, possibly reconditioned tractors imported from foreign countries. There are many importers in the grey market business, mostly on the West coast. Many grey market tractors come from Japan. An Internet search for "grey market tractors" will yield various options. The main drawbacks to the grey market are that this typically involves tractors that were not built to U.S. safety standards, a lack of availability of parts and service, and—unless you are willing to travel to the West Coast to shop for such a tractor—you are likely going to be buying something based only on photographs and the word of a grey market salesperson. As the saying goes: 'buyer beware.'³

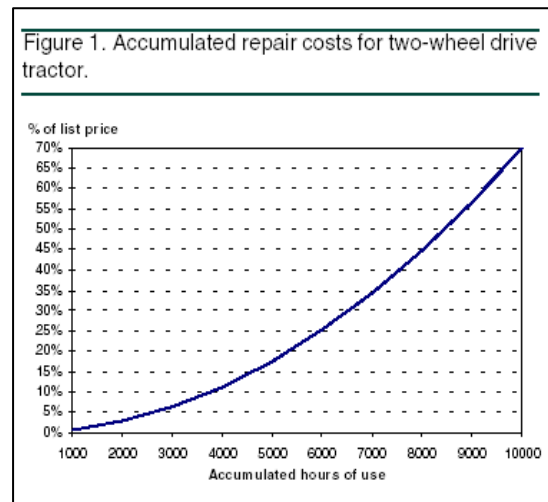
Buying a New Tractor

Some people buy new tractors. The price will be high but you will certainly know more about what you are getting as opposed to trying to evaluate a used tractor. Beginning growers with less mechanical experience sometimes find it appealing to buy new for this reason. One very nice feature of buying new is the potential for a warranty and service agreement with the dealer as well as the option of financing. Kubota, Case-International, and John Deere are likely to be three of the more likely options when buying new.

Maintenance, Repair and Opportunity Costs

How much does it cost to own and operate a tractor? This will obviously depend greatly on the tractor you purchase (new versus used), what it is used for, how it is cared for (regular maintenance such as oil changes and lubrication), and your own mechanical know-how. Figure 1 (at right) is excerpted from "Estimating Farm Machinery Costs" by William Edwards, extension economist, Iowa State University Extension (pub. no. A3-29; April, 2002). This figure shows how repair costs are likely to accumulate over time. Not surprisingly, as the number of hours of use increases, repair costs increase as a percent of the original price of the tractor.

In general, a used tractor will likely need more frequent and perhaps costly repairs so it is wise to factor this into the cost of a used tractor versus the price of buying a new tractor. If you are mechanically inclined and can do repairs yourself, great...but you also need to factor in the TIME this will require of you and also the opportunity cost if you miss tilling, seeding and cultivating deadlines because a tractor was not up and running when needed.



³ The following is excerpted from the Kubota website: "Used Kubota tractors, originally sold in Japan, are being imported into this country. These "gray market" units were not designed for sale in the United States. They were designed and manufactured for the Japan market and imported into the United States by individuals or entities independent of Kubota and without Kubota's authorization. These "gray market" units are different in several important respects from the tractors that Kubota makes for the United States, and which Kubota Tractor Corporation sells in the United States. These tractors are not ordinarily equipped with important safety equipment such as ROPS and seatbelt, PTO shield, safety decals, or operator's manual. Neither Kubota Tractor Corporation nor its affiliated company Kubota Corporation of Osaka, Japan, provides parts, service or any warranty support for Kubota "gray market" units in the United States. There is no responsibility whatsoever either by Kubota or its authorized dealers for these "gray market" units. Please be advised that since April 30, 1997, the importation, distribution and sale in the United States of Kubota "gray market" units under 50 PTO horsepower has been prohibited by a General Exclusion Order of the United States International Trade Commission."

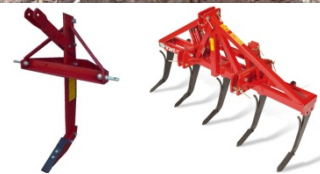
Primary Tillage Tools

Primary tillage refers to implements used for initial tillage of the soil following a cover crop or fallow period. There are 4 basic types of primary tillage tools in common use: the moldboard plow, chisel plow (or subsoiler), rotovator and spader.

The **moldboard plow** is a tool that turns under the top layer of soil. It has gotten a lot of bad publicity because it inverts the soil profile and leaves soil exposed to wind and rain and thus the risk of erosion. Used repeatedly without deeper tillage, it can also contribute to the development of a hardpan layer. These criticisms are certainly valid. Used properly, however, and in conjunction with other tools, a moldboard plow need not be viewed as necessarily negative. All tillage disrupts the soil in some way. The moldboard is certainly effective at turning under green manure crops and smaller plows can be found fairly cheaply. It is also possible to operate a moldboard plow and not completely turn the top layer under, a method sometimes referred to as ridge plowing. Growers on loose, sandy soils may find that the moldboard plow does not completely invert the soil.



The **chisel plow** (at right, top) is very unlike the moldboard plow. Rather than turning soil under, chisel plow shanks are narrow and "comb" through the soil with a lifting and slight rolling action. Chisel plowing improves soil drainage, breaks-up hard pan, and improves soil tilth. They are used prior to secondary tillage in areas where there is not significant material to incorporate or prior to moldboard plowing. A chisel plow does not fully incorporate residues. **Subsoiler** (2 photos at right, bottom) work even deep than a chisel plow with an even more pronounced lifting of the soil but without any rolling or turning of the soil. Subsoilers require as much as 2.5 times more horsepower and good traction. They do not incorporate residue.



Rotovators are the tractor version of the rototiller. They feature a number of tines that revolve thereby pulverizing and mixing the soil. Rotovators quickly and thoroughly incorporate cover crops and cash crop residue, can cut through sod, and can also prepare a fine seedbed. They are the most common soil preparation tool on vegetable farms. That said, their use as a primary tillage tool should be limited because it is easy to overuse the rotovator. The pulverizing, mixing action is hard on soil structure and soil biology. The best approach is to consider the rotovator as a secondary tillage tool to prepare a seedbed rather than a primary tillage tool.



Spaders are becoming a more popular option for some growers concerned about the deleterious affects of rotovators. A true spader has a series of articulated shovels on a central crankshaft. Less horsepower is required because the shovels go into the soil one at a time opening and loosening the soil. The up-and-down action does not smear the soil unlike the rotovator. The articulated spader can invert the soil profile, and can be used to incorporate cover crops and other residue, although more than one pass might be required depending on soil type and amount of residue. It is relatively easy to use the spader to incorporate green material in more sandy soils. With clay soils it can be more difficult or impossible to achieve completely satisfactory results. In contrast, a rotary spader works more like a rototiller with the shovels revolving in a circle. This type of machine more quickly incorporates cover crops but can cause the same compaction and smearing as the rotovator.



Other Essential or Optional Implements

What is essential for you will depend on your situation and needs. Some implements to consider include:

Mower—This is likely the most frequently used of all tractor implements. A finishing mower is best for cutting a lawn while a rotary mower is good for more rugged use (field roads, edges, clearing brushy areas, etc.). For cover crops, a flail mower is most often ideal. Sickle bar mowers can be cheap but are not well suited for use on most vegetable farms. See the glossary for an explanation of these different types of mowers.

Seed drill—Many vegetable farmers have a seed drill (photo at right) to effectively plant and establish cover crops. At a small scale you can do this by hand or with a strap-on broadcast seeder. This might require having a simple harrow or cultipacker (see below) to lightly cover the seed and ensure good seed to soil contact unless you are at a very small scale and can simply rake in seed by hand.



Field digger, field cultivator, spring harrow—These are very useful for secondary tillage and working soil that is being prepared for cover crops or cash crops that do not require a fine seedbed. They can also be used to begin working an area that has been in cover crops and or cultivating weeds in an area that is in fallow. Newer units, like the Perfecta (at right), are very nice while older units can be easy and cheap to find.



Disk or disk-harrow—A very useful tool for working up ground and working in residue. Small, five to six foot, disks are not as effective as larger units so this may not be high on the priority list unless you have a decent sized tractor. Some growers decline to use the disk because, like the moldboard plow, they invert the soil profile and can contribute to hardpan. Used judiciously and in conjunction with chisel plows and subsoilers, they are a very effective way to cut-up and lightly incorporate residue from a previous crop or cover crops. On sandy soils, they may be all that is needed to prepare a decent seed bed.



Cultipacker—An implement with a set of meeker disks and/or shallow tines used to lightly incorporate cover crop seeds and compress the soil to ensure good seed to soil contact thus ensuring good germination and a good stand.



Spreader—Used for spreading manure, compost or other materials. Older models are ground driven (meaning that the wheels of the spreader drive the moving parts that discharge material) while newer models are most often PTO-driven. Spreaders are either rear discharge or side discharge. Some spreaders are especially designed to handle liquid manure. Unless you have animals on your farm, or make and spread lots of compost regularly, a spreader is likely an item that can be borrowed, rented or the spreading can be done by a neighbor who is bringing manure to your farm. A drop spreader is an implement designed to handle a range of finer fertilizer materials.

Mulch Layer—A mulch layer is a tool that lays plastic mulch. Two disks open furrows, the plastic is rolled out, and then another set of disks bury the edges. Most larger, commercial organic farms use plastic mulch extensively and this tool is relatively simple and inexpensive. Most will also lay irrigation drip tape at the same time.



Plastic Lifter—A lifter aids in removing plastic mulch but these tools also make excellent under-cutters for crop such as garlic, beets, and other root crops.

Potato Digger—Most Potato diggers are designed with a shoe or shovel at the front end to lift tubers out of the ground followed by a chain to convey and jostle soil off the potatoes before they are either deposited in a bin or simply on the ground behind the implement. Some diggers can handle additional crops such as onions, beets, etc. Manufacturers include: Willsie, Zaga, and many others.



Cultivators—There are many, many different types of cultivation tools to remove weeds. An excellent DVD is available called Farmers and Their Weed Control Machines available from the University of Vermont. The following on-line publications provide descriptions, uses, and sources:

<http://www.uvm.edu/vtvegandberry/factsheets/orgweedmgmt.html>

<http://www.hort.cornell.edu/bellinder/publications/CultTools1.pdf>

<http://www.hort.uconn.edu/IPM/weeds/htms/weeders.htm>

Spike Tooth Harrow—These are not very commonly used anymore unless they are part of a larger cultivating unit. These feature many short spikes that comb through the soil and break up clods of soil to prepare an area for planting. They can also be used to lightly work in broadcast cover crop seeds. Likely not a priority item but old small units can be very cheap if not free.



Scraper blade—usually rear-mounted, these are useful for many tasks including plowing snow and smoothing and leveling ground. A blade may not be required for vegetable farming but on a rural homestead they can be very nice to have around. Used ones are often available at auctions.



Post-hole digger—this is an item than can likely be rented when you need it rather than owned, unless you anticipate needing to do lots of fencing on a regular basis.

Tire Chains—Although not an implement, tire chains are practically essentially in any northern, snowy area if you'll be using your tractor to plow snow.

Glossary of Terms⁴

3-point hitch—A hitch for holding, lifting and lowering implements. As the name suggests, the implement is attached to the tractor at 3 points (a triangle) which offers stability and strength. A 3-point involves two side arms and a top link. On newer tractors, all three arms are adjustable allowing one to adjust where and how an implement trails behind the tractor. Adjusting the top link controls the level or horizontal pitch of the implement. There are two main types of 3-point hitches, Category 1 and Category 2. Smaller tractors usually have Cat I. It is important to know which you have in terms of matching them with implements. Some garden tractors have a category 0 hitch and very large agricultural machinery may have Category 4. The higher the number the larger the hitch and connecting pins and it will be made from stronger components.

PTO or Power Take-off—The PTO is the means by which a tractor transfers power to an implement. It is a drive shaft that sticks out the back of the tractor which can power implements with moving parts, such as a rototiller, manure spreader, mower or hay bailer. As noted by George DeVault, the PTO is likely "the most dangerous feature of any tractor. The PTO shaft on most tractors spins at 540 revolutions per minute. At that speed, hair, loose clothing or anything else that gets tangled can wrap itself around the shaft nine times in just one second." PTOs on older tractors deserve extreme caution as they are often not fitted with the safety features standard on newer tractors.

Hardpan—a smeared and/or compacted layer of soil caused by repeated use of the same type of tillage implement over time that prevents moisture and roots from penetrating deeper into the soil.

Hydraulics and Live Hydraulics—Hydraulic arms are used on tractors to raise and lower hitches, belly-mounted cultivators, and front-end loader buckets. Pistons and cylinders filled with pressurized oil provide the lifting power. The term "live hydraulics" refers to the ability to operate hydraulics without having the PTO engaged. Older tractors utilize the power from the PTO to create oil pressure to operate hydraulic arms. Thus, on a

⁴ Some of this material was adapted from "the Small Tractor FAQ" <http://www.andrew.cmu.edu/user/kb13/glossary.htm>

tractor with live hydraulics, the lift arms can operate even when the clutch is disengaged. This is a nice feature to have when operating a front end loader.

Narrow front versus wide front—Common abbreviations in classifieds and elsewhere, NF and WF, refer to tractors with wheels placed close together and right underneath the engine in a tricycle formation (NF) versus having the wheels spaced apart to straddle crops or a raised bed (WF). Not only are narrow front tractors less safe on a hillside, on a vegetable farm, a wide front is essential. About the only thing going for a NF tractor is that it might be cheaper and it will have a tighter turning radius. With kits and parts, many NF tractors can be converted to WF but before you buy check on part availability.

Off-set Engine—A engine that is mounted to left side of a tractor so that the operator has a clear view of the ground below the tractor for accurate, close cultivation.

Fast Hitch, Quick Hitch— Two-point hitch alternatives found on some older tractors. They are inferior to the 3-point hitch and find implements for them may be difficult and will certainly limit options. All newer tractors have 3-point hitches that are standardized.

Grey market tractor—A used, reconditioned, imported tractor.

Flail Mower— A mower with many free-swinging, L-shaped knives attached to a horizontal shaft. A flail mower chops cover crops in small pieces allowing for quicker decomposition and incorporation. Many flail mowers have shoots to blow chopped forage into a wagon. If this is not desired, the shoot can be closed or the back opened up to allow the chopped material to fall to the ground. Example manufacturers: Befco, Vrisimo, Land Pride, John Deere.

Sickle Bar Mower—A cutting implement that functions like a large hedge trimmer with a set of reciprocating knives on a bar. The cutting bar extends out to one side of the tractor and cuts just above ground level. These are not all that useful on a vegetable farm as they were made for cutting hay in preparation for raking, drying, and baling.

Brush mower (Brush hog/Rotary mower) —These mowers have one or more blades that spin perpendicular to the ground like a normal lawn mower. They are heavy duty to handle dense stands, brush, and saplings. They are most useful for pathways and perimeters rather than field work.

Finishing Mower—A rotary mower designed to cut a lawn. Can be used to cut some cover crops but not intended for rugged use.

Tool Bar— As the name implies, this is a metal bar for mounting tools to a tractor. A tool bar might be at the front, middle (belly), or rear of the tractor. A multitude of different cultivating tools can be mounted to a tool bar. Some tool bars are single units while other implements may have multiple tool bars to position a large number of tools.



Draw bar—A flat horizontal metal bar at the rear of a tractor used for pulling wagons or implements that are not mounted using a three point hitch.



Horsepower— This is a measure of power and indicates a machine's ability to move a load. When comparing HP ratings and determining if a tractor has enough HP for your purposes, it is important to ensure you are comparing apples to apples. Listed or published horsepower ratings may refer to engine (or *indicated*) HP, PTO HP, or drawbar HP. The indicated horsepower of an engine is higher than the horsepower at the PTO shaft and this is greater than what is available at the toolbar for pulling an implement due to losses of power due to friction in the engine, transmission inefficiencies, rolling resistance and tire slippage. Drawbar horsepower (or *effective* horsepower) is the important figure to consider. The advertised horsepower of modern tractors is usually PTO horsepower while the horsepower of older tractors was generally measured at the drawbar.

Rope trip implements—Rope trip implements are from an earlier era and allow the tractor driver to raise and lower an implement such as a moldboard plow or field digger without getting off the tractor. This technology predates the use of hydraulics. While hydraulics are more advanced and likely preferable, many rope trip implements are perfectly acceptable and usable on a market farm.

Hydrostatic transmission—This eliminates the nuisance of changing gears and is especially useful when reversing direction often. A hydrostatic transmission is much safer than a clutch-activated power train and is very helpful for loader work. However, it consumes 15-20% of engine horsepower.

Power steering—As in a car, power steering makes steering much easier, especially when the tractor is stopped or moving very slowly. Power steering is essential for front loader work.

Resources⁵

Tractorhouse

www.tractorhouse.com

Nationwide new and used tractor and implement website. Post "wanted to buy" ads or search or browse classifieds. Useful to gauge prices for various makes and models and locate machinery locally and regionally.

Yesterdays Tractors

www.ytmag.com

Web site on older tractors with lots of pictures, discussion forums, info on repairs/restoration, etc.

TractorByNet

www.tractorbynet.com

Reviews, photos, classifieds, and dealers (especially for compact tractors)

Tractor Blue Book

www.pricedigests.com/other/tractorbluebook.htm

One source for used tractor values. \$24.95

Market Farm Implement

www.marketfarm.com/index.cfm

New and used implements for vegetable farming.

Roeters Farm Equipment

www.roetersfarmequipment.com

Specialize in new and used vegetable and farm equipment sales. They salvage antique tractors and equipment and hard-to-find equipment parts.

Buckeye Tractor

www.buctraco.com

Manufacturer of specialized agricultural equipment

Willsie Equipment Sales

www.willsie.com

Manufacturers and Distributors of Quality Fruit, Vegetable and Nursery Equipment. Also make custom-designed equipment

⁵ No endorsement of listed businesses or products is intended, nor is criticism implied of those not mentioned

TABLE 1: Horsepower Requirements for Tillage Tools and Other Implements¹		
Implement Type	Horsepower Required	Notes
Rotovator	$\frac{3}{4}$ hp per inch of tillage width ²	See Primary Tillage Tools text and notes below
Spading Machine	40 hp to 70 hp	Depends on make and model. Higher hp rated machines till deeper.
Chisel Plow	10 hp per shank ³	3, 4, 5, or 7 shank plows are common on market farms
Subsoiler	25 hp per shank ³	1, 2 and 3 shank models are common
Moldboard Plow	10-20 hp per plow share ⁴	Three-bottom plows require significant horsepower (70 plus) and very good traction.
Tandem Disk	5 hp per foot	Heavy duty disks require 8 to 10 hp per foot
Field Cultivator / Spring Tooth Harrow	4 to 5 hp per foot	
Flail Mower	5 to 10 hp per foot	Upper end of range is best esp. if cutting thick, dense cover crops.
Potato Digger	18 to 20 hp per row	
Bed-shaper (for raised beds)	5 to 10 hp per inch of bed height	The Lesche bed shaper can be handled by low hp tractors, requiring only 25 hp for a 4' bed.
Plastic Mulch Layer	7-10 hp per foot of bed	
Raised Bed Plastic Mulch Layer	15 to 20 hp per foot of bed	Depends on model of layer and height of raised bed.
Grain drill	2 hp per foot	
Sprayer	Less than 1 hp per foot	

1: Horse power needs below are for standard 2-wheel drive tractors. Horsepower requirements will be reduced by as much as $\frac{1}{2}$ if you have 4-wheel drive. Actual horsepower needs will vary based on soil type and traction. Tire tread, tractor weight, soil conditions and other factors will impact traction.

2: Actual horsepower needs will depend on the make and model of the tiller, soil type, and tilling conditions. For example, if another primary tillage tool is used prior to rototilling (chisel plowing for example) this will reduce the horsepower requirement. It is very important to buy a tiller that can be powered by your tractor but it is also true that too much power can be a problem. Tillers have maximum horsepower ratings. The $\frac{3}{4}$ HP per inch of tilling width is a rough guideline and can help ensure that you buy a tractor with enough power to handle various tillage tasks.

3: Subsoilers and Chisel plows also require good tire traction.

4: The Lesche bed shaper can be handled by low hp tractors, requiring only 25 hp for a 4' bed.

Drip-irrigation systems for small conventional vegetable farms and organic vegetable farms¹

Eric Simonne, Robert Hochmuth, Jacque Breman, William Lamont, Danielle Treadwell, and Aparna Gazula²

A drip-irrigation system—when properly designed, maintained and operated—can be a production asset for a small farm. Using drip irrigation for profitable vegetable production requires an understanding of several basic engineering and horticultural concepts and their application. The goals of this publication are to present the principles behind drip irrigation and some practical guidelines for successful and profitable use of drip irrigation.

1. Overview of drip irrigation

1.1 What is drip irrigation?

Drip irrigation (also known as trickle irrigation or micro-irrigation) is an irrigation method that allows precisely controlled application of water and fertilizer by allowing water to drip slowly near the plant roots through a network of valves, pipes, tubing and emitters. Plasticulture is the combined use of drip irrigation, polyethylene mulch and raised beds. Greatest productivity and earliness may be achieved in vegetable production by combining plasticulture with the use of transplants.

1.2 Is drip irrigation adapted to all operations?

Drip irrigation is not a silver bullet; it may not be applicable to all farms. Yet, when properly managed, it is a valuable production technique that may reduce labor and production costs while improving productivity. Small farmers considering the use of drip irrigation should evaluate both the advantages and disadvantages of this system to determine the benefits of drip irrigation for their operation.

1.3 What are the main advantages of drip irrigation?

Reduced water use: Because drip irrigation brings the water to the plant root zone and does not wet the entire field, drip irrigation typically requires half to a quarter of the volume of water required by comparable overhead-irrigation systems.

Joint management of irrigation and fertilization: Drip irrigation can improve the efficiency of both water and fertilizer. Precise application of nutrients is possible using

1. This document is HS1144, one of a series of the Horticultural Sciences Department, UF/IFAS Extension. Original publication date February 2008. Revised July 2008. Reviewed March 2015. Visit the EDIS website at <http://edis.ifas.ufl.edu>.
2. Eric Simonne, associate professor, Horticultural Sciences Department; Robert Hochmuth, Extension agent IV, North Florida Research and Education Center; Jacque Breman, emeritus Extension Agent IV, UF/IFAS Extension Columbia County; William Lamont, professor, Penn State University; Danielle Treadwell, assistant professor, Horticultural Sciences Department; and Aparna Gazula, commercial horticulture Extension agent II, UF/IFAS Extension Alachua County, UF/IFAS Extension, Gainesville, FL 32611.

The use of trade names in this publication is solely for the purpose of providing specific information. UF/IFAS does not guarantee or warranty the products named, and references to them in this publication does not signify our approval to the exclusion of other products of suitable composition. All chemicals should be used in accordance with directions on the manufacturer's label. Use pesticides safely. Read and follow directions on the manufacturer's label.

The Institute of Food and Agricultural Sciences (IFAS) is an Equal Opportunity Institution authorized to provide research, educational information and other services only to individuals and institutions that function with non-discrimination with respect to race, creed, color, religion, age, disability, sex, sexual orientation, marital status, national origin, political opinions or affiliations. For more information on obtaining other UF/IFAS Extension publications, contact your county's UF/IFAS Extension office.

U.S. Department of Agriculture, UF/IFAS Extension Service, University of Florida, IFAS, Florida A & M University Cooperative Extension Program, and Boards of County Commissioners Cooperating. Nick T. Place, dean for UF/IFAS Extension.

drip irrigation. Hence, fertilizer costs and soluble nutrient losses may be reduced with drip irrigation. Nutrient applications may also be better timed to meet plant needs.

Reduced pest problems: Weed and disease problems may be reduced because drip irrigation does not wet the row middles or the foliage of the crops as does overhead irrigation.

Simplicity: Polyvinyl chloride (pvc) and polyethylene parts are widely available in several diameters and are easy to assemble. Many customized, easy-to-install connectors, endcaps, and couplers are available in different diameters. Cutting and gluing allows for timely repairs.

Low pumping needs: Drip systems require low operating pressure (20–25 psi at field entrance, 10–12 psi at the drip tape) compared to overhead systems (50–80 psi). Many existing small pumps and wells may be used to adequately irrigate small acreage using drip systems.

Automation: Drip-irrigation application may be simply managed and programmed with an AC- or battery-powered controller, thereby reducing labor cost.

Adaptation: Drip systems are adaptable to oddly shaped fields or those with uneven topography or soil texture, thereby eliminating the underutilized or non-cropped corners and maximizing the use of available land.

Production advantages: Combined with raised beds, polyethylene mulch, and transplants, drip irrigation enhances earliness and crop uniformity. Using polyethylene mulch also increases the cleanliness of harvested products and reduces the risk of contamination with soil-borne pathogens. Reflective mulches further help reduce the incidence of viral diseases by affecting insect vectors, such as thrips, whiteflies or aphids.

1.4 What are the disadvantages of drip irrigation?

Drip irrigation requires an economic investment: Drip-irrigation systems typically cost \$500–\$1,200 or more per acre (Table 1). Part of the cost is a capital investment useful for several years, and another part is due to the annual cost of disposable parts. Growers new to drip irrigation should start with a relatively simple system on a small acreage before moving to a larger system.

Drip irrigation requires maintenance and high-quality water: Once emitters are clogged or the tape is damaged,

the tape must be replaced. Water dripping from an emitter and the subsequent wetting pattern are hard to see, which makes it difficult to know if the system is working properly. Proper management of drip irrigation requires a learning period.

Water-application pattern must match planting pattern: If emitter spacing (too far apart) does not match the planting pattern, root development may be restricted and/or plants may die.

Safety: Drip tubing may be lifted by wind or may be displaced by animals unless the drip tape is covered with mulch, fastened with wire anchor pins, or lightly covered with soil.

Leak repair: Drip lines can be easily cut or damaged by other farming operations, such as tilling, transplanting, or manual weeding with a hoe. Damage to drip tape caused by insects, rodents or birds may create large leaks that also require repair.

Drip-tape disposal causes extra cleanup costs after harvest: Planning is needed for drip-tape disposal, recycling or reuse.

1.5 How does my drip-irrigation system affect organic certification?

Growers considering certified organic production should first become familiar with the National Organic Program (NOP) (<http://www.ams.usda.gov/NOP/indexIE.htm>) and the principles of organic production (Ferguson, 2004a,b; Treadwell, 2006). All production inputs used in certified organic production must follow the National List of Allowed and Prohibited Substances (Code of Federal Register [CFR] 205.600 of the National Organic Program). Drip irrigation itself (standard drip tape) is allowed. Products typically used with drip irrigation in conventional production systems that may or may not be allowed in certified organic production may be classified in four groups: water, products for drip-irrigation maintenance (algaecides, disinfectants and acids), fertilizers, and pesticides (Table 2).

The design and maintenance of a drip-irrigation system should be clearly outlined in the Organic System Plan (farm plan required for certification), including any inputs that will be delivered through the drip-irrigation system. In all cases, contact your certifying agency before using a product to confirm that use of that product will not jeopardize organic certification.

Drip-irrigation water. In most cases, groundwater, surface water, rainwater and potable water may be used in certified organic production. In some instances, the certifying agency may request a water analysis.

Products for drip-irrigation maintenance. Within stated restrictions (see Table 2), CFR 205.601 of the NOP lists the following substances as allowable as synthetic algaecide, disinfectant, and sanitizers: (1) alcohols, including (a) ethanol and (b) isopropanol; (2) chlorine materials [except that residual chlorine levels in the water shall not exceed the maximum residual disinfectant limit under the Safe Drinking Water Act], including (a) calcium hypochlorite, (b) chloride dioxide, (c) sodium hypochlorite; (3) hydrogen peroxide; and (4) soap-based algaecide/demisters. Additionally, under NOP Rule CFR 205.105, citric acid is allowed when irrigation water needs to be acidified. (See Section 4.2 of this paper for why and how much). However, other compounds commonly found in ready-to-use drip-irrigation cleaners and maintenance products and typically used in conventional systems (see Section 4.2, below) are prohibited in certified organic production.

Fertilizers and pesticides. No specific ruling prohibits NOP-compliant products from being distributed through a drip-irrigation system. Plans to use drip irrigation to distribute fertilizers and/or pesticides should be clearly outlined for approval in the Organic System Plan. When in doubt, consult first with your certifying agency. All growers are obligated to follow state and federal guidelines for injecting inputs through irrigation systems (see Section 2.0, below).

1.6 Is drip irrigation considered a Best Management Practice?

Yes. Best Management Practices (BMPs) are cultural practices that help reduce the environmental impact of production while maintaining or increasing productivity. The BMP program for vegetables grown in Florida is described in “Water quality/quantity best management practices for Florida vegetable and agronomic crops” (Florida Department of Agriculture and Consumer Services, 2005). The BMP manual describes all the BMPs that apply to vegetable production, as well as a decision-tree to identify the BMPs that apply to each operation and guidelines for completing and submitting the Notice of Intent to Implement (Gazula et al., 2007).

Participation in the Florida BMP program and the organic certification program are two separate processes. Vegetable growers who are enrolled in the statewide BMP program

receive three statutory benefits: (1) a waiver of liability from reimbursement of cost and damages associated with the evaluation, assessment, or remediation of nitrate contamination of groundwater (Florida Statutes [F.S.] 376.307); (2) a presumption of compliance with water-quality standards (F.S. 403.067 (7)(d)), and (3) eligibility for cost-share programs (F.S. 570.085 (1)).

Specific vegetable BMPs that address drip irrigation include BMP 33 “Optimum fertilization application/management”, BMP 34 “Chemigation /fertigation”, BMP 39 “Irrigation system maintenance and evaluation”, and BMP 47 “Plasticulture farming”. Additional BMPs involving drip irrigation include BMP 26 “Soil testing/soil pH”, BMP 36 “Water supply” and BMP 40 “Irrigation scheduling”. BMP implementation requires record keeping (see Table 3). When properly implemented, all BMPs that apply to drip irrigation help to increase efficiency in the use of water and nutrients.

1.7 What is the best way (or best unit) to express irrigation rates when drip irrigation is used?

For irrigation systems that entirely wet the field (overhead or flood systems), irrigation rates are typically expressed in inches. This unit of measurement represents a vertical amount of water (or a height). The actual “volume” of water is calculated by multiplying the height of water by the field surface. For example, 1 acre inch is the volume of water present on a 1-acre field with a 1-inch depth: 1 acre inch = 27,154 gallons.

Because drip irrigation does not wet the entire field, expressing drip-irrigation volumes as a height of water poorly represents reality. Instead, drip-irrigation volumes should be expressed in gallons-per-100-linear-foot-of-drip-tape. In some cases, drip-irrigation volumes can be converted to and from water heights by considering the relative surface of the field under plastic mulch. For example, the relative surface under plastic mulch of a 1-acre field with 30-inch-wide beds of 4-ft centers is 62.5% (2.5 ft/4 x 100). Hence, if 0.5 acre inch needs to be applied to that field through a drip-irrigation system, the total volume of water needed is 8,484 gallons (27,150 / 2 x 0.625). Because in a 1-acre field with beds of 4-ft centers there are 10,890 linear-bed-feet of plastic, the drip-irrigation rate should be reported as 78 gallons/100ft (8,484/108.90). If a drip tape with a 24-gal/100-ft/hr flow rate is used, it will take 3 hours and 15 minutes to apply this amount of water (78/3 = 3.25 hrs).

In heavy soil, it is reasonable to assume that a drip tape installed in the middle of the bed will be sufficient to wet the entire bed width. However, research has shown that, on Florida's sandy soils, the wetted width seldom exceeds 18 inches (1.5 ft) when a single drip tape is used. Hence, the assumption made in the calculation above—that the entire bed width is wetted (and, therefore, irrigated)—is not correct for most drip-irrigation systems in Florida. The actual wetted width should be used in place of the bed width.

2. Components of a drip-irrigation system

The type and sequence of components in a drip-irrigation system are typically the same for all field sizes. Yet, based on field size (and water need), component sizes (diameter) may vary. Larger components tend to be more expensive. The backflow-prevention devices—comprised of two check valves and the lowpressure drain, also known as “anti-siphoning device”—are the only components required by Florida law (FS 487.021 and 487.055 and Florida Department of Agriculture and Consumer Services Rule 5E-2.030) when fertilizer or chemicals are injected into the system (see Section 2.6, below). The actual selection of a specific component (with the exception of the backflow-prevention device) generally needs to be made on a case-by-case basis. (See Table 11 for additional readings on this topic.) The following is a brief description of the main components of a typical drip-irrigation system.

2.1 Water source

Common water sources for drip irrigation are surface water (pond, river, and creek), groundwater, and potable water (from municipality, county or utility company) (Fig. 1). Use the water source that will provide the largest amount of water of greatest quality and lowest cost. Potable water is of high, constant quality, but is by far the most expensive.

2.2 Pumping system

The role of the pumping system is to move water from the water source to the field through the distribution system. Pumping systems may be classified as electric powered systems, gas/diesel powered systems, and gravity systems. Gas/diesel pumps offer the greatest versatility in isolated fields (Fig. 2).

2.3 Distribution system

The role of the distribution system is to convey the water from the source to the field. Distribution systems may be above ground (easily movable) or underground (less likely

to be damaged). Pipes are most commonly made of PVC or polyethylene plastics. Aluminum pipes are also available, but are more difficult to customize, cut, and repair. The size and shape of the distribution system may vary widely from field to field and from farm to farm.



Figure 1. This pond provides surface water for the irrigation of strawberry.
Credits: Eric Simonne.



Figure 2. Diesel engines mounted on a trailer offer the greatest flexibility of use.
Credits: Eric Simonne.

2.4 Drip tape (or drip tube)

The drip-irrigation system delivers water to each plant through a thin polyethylene tape (or tube) with regularly spaced small holes, called emitters. Selection of drip tape should be based on emitter spacing and flow rate. The typical emitter spacing for vegetables is 12 inches, but 8 inches or 4 inches may be acceptable. Dry sections of soil may develop between consecutive emitters when a wider emitter spacing (18 inches) is used on sandy soils. Flow rates are classified into low flow (<20 gal/100ft/hr), medium

flow (20 to 30 gal/100ft/hr) and high flow (>30 gal/100ft/hr). The risk of emitter clogging is generally higher with the lower-flow drip tapes.

The following equivalent units are commonly used to report flow rates: gallons/100ft/hr or gallons/emitter/hr. For example, with a 12-inch emitter spacing, 24 gallons/100ft/hr = $24/100 = 0.24$ gallons/emitter/hr. In the field, drip-irrigation tape should be installed with emitters upward (looking up) to prevent clogging from sediment deposits settling in the emitters between irrigation events. Drip tapes are widely available from several manufacturers



Figure 3. Drip tapes can be distinguished and recognized by their features. Note the emitter (on the four tapes on the right) and the turbulent flow channels (on the two tapes on the left). Credits: Eric Simonne.

2.5 Injectors

Injectors allow the introduction of fertilizer, chemicals and maintenance products into the irrigation system. Florida law requires the use of an anti-siphoning device (also called backflow-prevention device) when fertilizer, chemicals or any other products are injected into a drip-irrigation system (Fig. 4). Backflow-prevention devices ensure the water always moves from the water source to the field. The devices prevent chemicals in the water from polluting the water source.



Figure 4. Back-flow prevention made of two ball valves and a vacuum breaker are placed upstream of the Venturi injector. Credits: Eric Simonne.

The most common injectors used with small drip-irrigation systems are the Venturi (or Mazzei) injector (Fig. 4) and the Dosatron (Fig. 5). Because Venturi injectors involve no moving parts and are less expensive, they are commonly used on small farms (Table 2). The injector is typically located as close as possible to the irrigation zone, but before the filter.



Figure 5. Injection made possible with a Dosatron. Credits: Eric Simonne.

2.6 Filtration system

Because drip-irrigation water must pass through the emitters, the size of the particles in the water must be smaller than the size of the emitter to prevent clogging. Nearly all manufacturers of drip-irrigation equipment recommend that filters be used. The manufacturer generally will not honor warranties unless filters are used.

The filtration system removes “large” solid particles in suspension in the water. Different types of filters are used based on the type of particles in the water. Media filters (often containing angular sand) are used with surface water when large amounts of organic matter (live or dead) need to be filtered out. Screen filters or disk filters may be used with groundwater (Fig. 6). A 200-mesh screen or equivalent is considered adequate for drip irrigation. When the water contains sand, a sand separator should be used.

Rapid clogging may occur when no filter or the incorrect type of filter is used. A filter needs to be cleaned when the difference in pressure across the filter (measured before and after the filter) is greater than 5–8 psi. A drip-irrigation system should never be operated without a filter even if the filter requires frequent cleaning. Failure to use a filter will result in clogged drip-tape emitters, often resulting in poor uniformity and sometimes in crop loss. The filter should be cleaned as often as needed. Efforts should be made to

understand the cause of the rapid clogging, and remediation for the problem should be developed.



Figure 6. Disk filters are made of stacked disks with small openings. They are usually color coded to indicate the filtration mesh. Credits: Eric Simonne.

The presence of the filter after the point of fertilizer injection means totally soluble fertilizers must be used. Otherwise fertilizer particles may contribute to filter clogging. Conventional growers may use two types of fertilizer materials: ready-to-use true solutions or dissolved granular fertilizer. Ready-to-use solutions are easily injected. However, granular fertilizers are sometimes coated with a thin layer of oil to prevent dusting. Upon dissolution of the fertilizer granules, an oily film may form at the surface of the solution. Injecting the oily film together with the fertilizer may contribute to filter and emitter clogging. Certified organic fertilizers are seldom true solutions (they may be suspensions or dilute colloidal solutions), and may also contribute to filter clogging. Consequently, the actual fertilizer rate applied may be reduced by the amount of fertilizer particles trapped by the filter. In both cases, small-scale trials may be needed to assess the clogging risk of each fertilizer material used.

2.7 System controls

System controls are devices that allow the user to monitor how the drip-irrigation system performs. These controls help ensure the desired amount of water is applied to the crop throughout the growing season.

Pressure regulators, installed in-line with the system, regulate water pressure at a given water flow (Fig. 7), thereby helping to protect system components against damaging surges in water pressure. Pressure surges may occur when the water in the pipe has a velocity >5 feet /second (“water

hammer”) or when water flowing in the pipe has no avenue for release due to a closed valve or a clog in the pipe.



Figure 7. Pressure regulators are installed side-by-side in this system to allow a greater flow rate. Note the small injection port for chemical injection.

Credits: Eric Simonne.

Water meters monitor and record the amount of water moving through a pipe where the water meter is installed (Fig. 8). When a stopwatch is used together with a water meter, it is possible to determine the water flow in the system in terms of gallons-per-minute.



Figure 8. Water meters installed near the field.

Credits: Eric Simonne.

Pressure gauges monitor water pressure in the system and ensure operating pressure remains close to the recommended or benchmark values. Based on where the pressure gauge is installed, it will measure water pressure in a various ranges, from 0-100 psi near the pump to 0-20 psi at the end of drip tape (Fig. 9). Pressure gauges may be installed at set points (near the pump, before and after the filter, near the field; see Fig. 10). They can also be mounted as portable devices and installed temporarily at the end of a drip tape.



Figure 9. A portable pressure gauge measures pressure at the end of the drip tape.
Credits: Eric Simonne.



Figure 10. A fixed pressure gauge. Note the needle bathing in oil to prevent needle vibration and damage.
Credits: Eric Simonne.

Soil-moisture-measuring devices (such as tensiometers, capacitance probes or Time Domain Reflectometry probes) are used to measure soil moisture in the root zone of the crop (Muñoz-Carpena, 2004). The Florida Extension Service recommends maintaining soil-water tension between 8 and 12 centibars 6 inches away from the drip tape and at the 12-inch depth.

Electrical timers connected to solenoid valves (Fig. 11) may be used to automatically operate a drip-irrigation system at pre-set starting and ending operating times of day.



Figure 11. Solenoid valves connected to a timer allow sequential irrigation of different zones.
Credits: Eric Simonne.

3. Tips for Design and Layout

Irrigation engineers are trained and certified to properly design drip-irrigation systems. Relying on their expertise will pay off in the long run. Many small-scale growers abandon drip irrigation because of poor performance of flawed designs or inadequately modified designs. Do not hesitate to ask for professional help when designing your drip-irrigation system or when planning major modifications to an existing system. The following section presents the basics of system design, but is not a substitute for the professional services of a qualified engineer.

3.1 Planning a drip irrigation system: Horticultural considerations

The goal of drip irrigation is to bring water to the crop. The main parameters that determine crop water use are the type of crop planted and row spacing. A drip irrigation system should be able to supply 110%–120% of crop water needs. In other words, the system should be slightly oversized. In designing a drip-irrigation system, it is common to consider that vegetable crops ordinarily need approximately 1.5 acre-inches of water for each week of growth or approximately 20 acre-inches of water per crop. Actual crop water use will be more or less than this amount, depending on weather and irrigation efficiency.

3.2 Planning a drip irrigation system: Design considerations

Start with what is already available—the water source or the field. If a water source is already available (pond or well), the amount of water available may be used to calculate the maximum size of each irrigation zone (Table 4).

If no water source is available, the amount of water needed by the crop—based on the size of the planted area—may be

used to calculate the type of well or pond size needed (Table 5).

Lay out of beds and rows. Because differences in altitudes affect water pressure, it is preferable to lay out beds perpendicular to the slope. This arrangement of rows is called “contour farming” (Fig. 12).



Figure 12. In contour farming, rows are laid perpendicularly to the natural field slope, which allows each drip tape to be parallel to each other and contour (The drip tape is laid horizontally). Credits: Eric Simonne.

Pipe sizing. Larger-diameter pipes are more expensive than smaller-diameter pipes, but larger-diameter pipes carry more water. All delivery mains and secondary lines should be sized to avoid excessive pressure losses and velocities and should be able to withstand a pressure of 80 psi.

Excessive pressure losses result in a large difference in pressure from the pressure level at the beginning of the line compared to the pressure level at the end of the line. Since the flow rate of the emitters is usually a function of water pressure, the water application at the beginning of the line may be very different from the water application at the end of the line. This difference will result in irregular water application on the crop.

Excessive water velocities (>5 feet/second) in the lines—the result of a too-small diameter—are likely to create a water hammer (pressure wave), which can damage the delivery lines. Growers should be aware of the maximum acreage that can be irrigated with different pipe sizes at a water velocity of 5 feet/second (Table 6).

The maximum length of drip tape should be based on the manufacturer’s recommendation and the actual terrain slope. Typically 400–600 feet are maximum values for drip-tape length. Excessive length of laterals will result in poor uniformity and uneven water application. When the field is longer than 400 - 600 feet, consider placing the secondary

(submain) line in the middle of the field—rather than at the end—and connect drip tape on both sides.

3.3 Layout tips

A Y-connector is convenient on a drip system connected to a hose bibb because a garden hose can be connected to the other side.

To evaluate source flow rate, run water full force from an outside faucet and note the number of seconds required to fill a bucket of known volume. Calculate the gallons of flow per hour (gph) by dividing the bucket size in gallons by the number of seconds required to fill it, then multiply by 3600 seconds for gallonsper- hour:

System flow rate (in gph) = Bucket volume (in gallons) / time needed to fill (in seconds) x 3,600 seconds per hour

The maximum flow is considered to be 75% of the flow-rate measure above. Maximum flow is the largest number of gallons available for use at one time while operating a drip-irrigation zone.

Use goof plugs to plug holes in the mainline that are no longer needed due to system modification.

Common setup mistakes include not installing a filter or a pressure reducer, using excessively high lengths of mainline, and/or adding too many drip emitters.

Zones should be approximately the same size throughout your drip-irrigation system. Variation in zone sizes will reduce the efficiency of pump operation. When all zones are of the same size, pipe sizes and system cost will normally be minimal. The length of the mainline should not exceed 200 feet in a single zone.

Pressure regulators may be required if the pressure produced by the pump is too large or if zones vary greatly in size. If the pump was sized for a previously existing sprinkler system, it would likely operate at pressures that are excessive for the components of a drip system. If the system consists of different size zones, the pump must deliver the amount of water required in the largest zone at the pressure required by the tape used for lateral lines. If some zones are significantly smaller, the pump will produce higher pressure at the smaller discharges required by these zones. This pressure must be reduced by pressure regulators to the pressure-level required by the drip tape in the lateral lines.

4. Drip system maintenance and operation

The goal of drip-irrigation maintenance is to preserve the high uniformity of water application allowed by drip irrigation. A successful program of maintenance for a drip-irrigation system is based on the prevention-is-the-best-medicine approach. It is easier to prevent a drip tape from clogging than to “unclog” it or replace it. See Table 11 for additional readings on this topic.

4.1 Water sampling for drip irrigation

An essential part of drip-irrigation management is determining water quality through water testing. Water testing will help determine water chemical composition, pH, and hardness (Table 7). These parameters have direct implications on chlorination, acidification and filtration needs for irrigation water. Analyses performed by the Extension Soil Testing Laboratory at the University of Florida (UF-IFAS ESTL) determine pH, electrical conductivity, Ca, Mg, Fe, Mn, Na, Cl, hardness, total carbonates, and suspended solids. (A sample water test information sheet is available at <http://edis.ifas.ufl.edu/pdffiles/SS/SS18400.pdf>.) These tests are designed to test water suitability for irrigation; they do not indicate whether water is suitable for human consumption.

4.2 The prevention-is-the-best-medicine maintenance program for drip irrigation

This maintenance program is based on filtration, chlorination/acidification, flushing and observation (see Table 8). Filters were described in section 2.5, above. Chlorination and acidification go together.

Chlorination consists of the introduction of a chlorinating compound (most often chlorine gas or sodium hypochlorite) that produces hypochlorous acid (HOCl). In its non-dissociated form, hypochlorous acid oxidizes organic matter and precipitates iron and manganese.

The chlorination point should be placed before the main filters so the precipitates that form by the chlorination can be removed from the water. In Florida, most groundwater is alkaline (pH up to 8.4). The proportion of hypochlorous acid in the non-dissociated form (HOCl) is significantly greater at lower pH. Hence, acidification makes chlorination more efficient. In conventional production, hydrochloric acid (HCl and also called muriatic acid), sulfuric acid or phosphoric acid may be used.

The amount of acid and chlorine needed to achieve a 1- or 2-ppm free chlorine concentration at the end of the line may be calculated by following the direction provided in EDIS Publication CIR1039 *Treating Irrigation System with Chlorine*. When applied correctly, the small amount of chlorine needed for drip-tape maintenance will be harmless to the crop grown in the soil.

Water acidification may be a challenge in certified organic production because NOP standards allow only acetic acid, citric acid, peracetic acid and other natural acids for use as a cleaner for drip-irrigation systems. It may take large, unpractical and expensive amounts of these acids to significantly reduce water pH.

Certified organic growers have three alternative options for drip-tape maintenance. First, chlorination may be done without acidification although this is less efficient and will require more product. Second, when economical and feasible, certified organic growers can choose to use potable water for drip-tape maintenance. Potable water may have a lower pH than well water, but analyses of both waters are needed to make this assessment. Third, non-chlorine-based products—such as natural chelating agents, hydrogen peroxide, or ozone—may be used to oxidize organic matter in the water. When in doubt, however, consult with your certifying agency for an acceptable plan for maintenance of your dripirrigation system.

Flushing may be accomplished automatically at each irrigation cycle when self-flushing end caps are used. Additional labor is required for flushing when the drip tape is tied or capped. Flushing may also be achieved by increasing pressure so to temporarily increase water velocity in the drip tape to 4–6 feet/second. Flushing takes all the precipitates and slime that may develop outside of the drip tape.

Observation and record keeping are needed throughout the season to ensure that the performance of the drip-irrigation system does not change. Measure pressure and flow, including how these change throughout the season (Table 9).

4.3 Scheduling drip irrigation

An adequate method of irrigation scheduling is needed to reduce water needs, maximize crop yield and uniformity, and reduce nutrient movement below the root zone.

Scheduling irrigation consists of knowing when to start irrigation and how much to apply. A complete irrigation-scheduling program for drip-irrigated vegetables includes a target rate of water application adjusted to weather demand and plant age (Table 10), as well as a measurement of soil

moisture, an assessment of rainfall contribution, a rule for splitting irrigation, and detailed record keeping (tables 3 and 11). The actual size of the wetted zone may be visualized by injecting a soluble dye into the water and digging the soil profile (Simonne et al., 2005).

Because drip irrigation does not wet the entire field, the best unit for expressing crop water needs and irrigation amounts is volume-of-water-per-length-of-row, such as gallons-per-100-feet (gal/100ft), which is the most commonly used unit. Vertical amounts of water (expressed in inches; 1 acre inch = 27,154 gallons) are commonly used with overhead and seepage irrigation, but should not be used for drip irrigation. (See Table 11 for additional readings on this topic.)

4.4 Fertigation and chemigation

Fertigation (the injection of soluble fertilizer through the drip-irrigation system) should be considered an integral part of the fertility program based on soil testing. Detailed fertigation schedules for all major vegetable crops grown in Florida are available in the Vegetable Production Handbook for Florida (Olson and Simonne, 2007). This series of EDIS publications is available online http://edis.ifas.ufl.edu/TOPIC_VPH. Proper nutrient management for vegetables grown with drip irrigation includes (1) soil testing, (2) understanding the recommendation, (3) correctly calculating fertilizer rates (see Table 12), (4) monitoring plant nutrient content, and (5) trapping residual nutrients by planting a second cash crop or a cover crop. In addition, fertilizer applicators should be properly calibrated.

Conventional growers have a wide array of soluble-fertilizer sources to choose from. Important characteristics of liquid fertilizers are the fertilizer content (lbs of N, P₂O₅ and K₂O/gallon of liquid fertilizer) and the ratio among elements. When all the P₂O₅ is applied pre-plant, most vegetables require a 1:0:1 type of liquid fertilizer (as much K₂O as N and no P₂O₅). However, certified organic growers have fewer choices for liquid fertilizers. The NOP rule limits the use of sodium nitrate (NaNO₃) to 20% of the total N. For example, if the seasonal N rate is 150 lbs/A—as for watermelon or cantaloupe (muskmelon), 20% of the seasonal N represents 30 lbs N/A/season. If the seasonal N rate is 200 lbs/A—as for tomato and bell pepper, 20% represents 40 lbs N/A/season. Some formulations of seaweed or fish emulsions may be allowed by the NOP, but the use of these fertilizers in a drip-irrigation system may increase the risk of emitter clogging.

5. Glossary of Terms

Acid: A compound that releases H⁺ ions when dissolved into solution. Compounds such as hydrochloric acid (HCl) or acetic acid (CH₃-COOH) are acids.

Acidification: The introduction of an acid—such as phosphoric, sulfuric or hydrochloric (muriatic) acid—into an irrigation system. This practice is mostly done in maintenance to improve the effectiveness of chlorination.

Algicide: A substance toxic to algae.

Anti-siphon device (see backflow-prevention device): A safety device used to prevent back flow of irrigation water into the water source by back-siphonage.

Application efficiency: The percentage of water applied by an irrigation system and stored in the root zone available for water use.

Application rate: The average rate at which water is applied by an irrigation system. For drip irrigation, rate is expressed as gallons/hour/100ft or gallons/minute/emitter.

Backflow-prevention device (see anti-siphon device): A device required by Florida law and preventing contaminated water from being sucked back into the water source should a reverse-flow situation occur.

Bactericide: A substance that kills bacteria.

Base: A compound that produces OH⁻ ions when dissolved into solution. Compounds such as potassium hydroxide (KOH) or sodium hydroxide (NaOH) are bases.

Best Management Practices (BMP): A set of cultural practices known to increase the efficiency of the irrigation and fertilization program while minimizing the environmental impact of production.

Certifying agency: An independent, accredited third party that verifies that a certified-organic operation is compliant with the regulations described in the National Organic Standards as appropriate for their farming system.

Chelate: A compound that binds polyvalent metals at two or more cation-exchange sites. Chelate is often a component of ready-to-use formulations for drip-irrigation cleaning. The use of synthetic chelates is not allowed in certified-organic production for cleaning drip-irrigation systems, but synthetic chelates may be used

in certified-organic production to correct a documented micronutrient deficiency.

Chemigation: A general term referring to the application of water-soluble chemicals into the drip-irrigation system. Chemigation includes (when allowable) the application of fertilizers, acids, chlorine and pesticides.

Chlorination: The introduction of chlorine—at a calculated rate—into an irrigation system. Chlorination can use liquid sodium hypochlorite (household bleach) or chlorine gas. Some chlorinating agents are allowed in certified organic production.

Cleaning agent: A substance used to remove dirt, filth and contaminants.

Control valve: A device used to control the flow of water. Control valves turn on and off water to the individual zones.

Detergent: A synthetic substance that is not a soap and that is used to change the surface tension to remove oil and grease and other substances relatively insoluble in water. Detergents are not allowed in certified organic production.

Disk filter: A stack of round, grooved disks used to filter water in a drip-irrigation system. As the size of the grooves decreases, the more the water is filtered. Each disk has grooves on both sides. Sediments and organic matter accumulate on the disks as water passes through the grooves. Disks are reusable. Once taken apart, they can be easily cleaned with pressured water and/or a detergent solution.

Drip irrigation: A method of irrigation using the slow application of water under low pressure through tube openings or attached devices just above, at or below the soil surface.

Electronic Database Information System (EDIS): The on-line database where the science-based, peer-reviewed and up-to-date recommendations of UF/IFAS Extension are accessible (<http://edis.ifas.ufl.edu>).

Emitter: A dispensing device or opening in a micro-irrigation tube that regulates water application. An emitter creates a controlled flow expressed in gallons/minute/emitter or gallons/100ft/hr.

Emitter spacing: Distance between two consecutive emitters. Typical emitter spacings for vegetable crops are 4, 8 and 12 inches.

Evapotranspiration (ET): The combined losses of water by evaporation from the soil and transpiration from the plant.

Fertigation: The application of soluble fertilizer (plant nutrients) through a dripirrigation system. Fertigation is allowed in certified-organic systems provided the fertilizer sources used are allowed by NOP standards.

Field capacity: The water content of the soil after all free water has been allowed to drain by gravity.

Filter: A canister device containing a screen or a series of disks of a specified mesh or filled with a coarse solid medium and designed to catch solid particles large enough to clog emitters.

Fittings: The array of coupling and closure devices used to construct a drip system and including connectors, tees, elbows, goof plugs and end caps. Fittings may be of several types, including compression, barbed, or locking (spin or ring).

Flow: The amount of water that moves through pipes in a given period of time. For micro-irrigation (drip irrigation), flow is expressed in gallons-per-hour (gph) or gallons-per-minute (gpm).

Flow meter: A device used to measure changes in flow in a drip-irrigation system over the course of a crop cycle.

Goof plug: An insertable cap used to plug holes in mainline and microtubes where drip devices have been removed or are no longer needed or when an accidental hole needs to be plugged.

Hole punch: A device that makes round holes in the pipes so to connect drip tape with laterals (available in different diameters).

Hydrochloric acid (HCl): An acid often used to lower the pH of water to increase the efficiency of chlorination. Use of HCl is prohibited in certified organic production.

Hypochlorous acid (HOCl): The weak acid generated by chlorinating products. Hypochlorous acid destroys organic matter. Use of HOCl is restricted in organic production.

Irrigation schedule: The watering plan and procedures that determine the proper amount of water to apply, the operating time, and the frequency of an irrigation event.

Mainline: The tubing used in the drip system. Mainline is sometimes called lateral line. It may be made of hard

PVC or soft polyethylene material and comes in diameters ranging from 0.5–4 inch.

Mazzei injector (see venturi injector): Patented T-shaped, venturi-type injector that does not involve moving parts.

Media filter: A pressurized tank filled with fine gravel and sand. The sand is placed on top of the gravel. Sharp-edged sand or crush rock are more efficient in catching soft algal tissue than round particles. Media filters should be used for filtering water that contains high levels of organic matter.

Micro-irrigation: Synonym for drip irrigation.

Muriatic acid: Another name for hydrochloric acid (HCl).

National Organic Program (NOP): Federal program created as a result of the Organic Foods Production Act of 1990 (title IX of the 1990 Farm Bill) and operated under the USDA Agriculture Research Service (<http://www.ams.usda.gov/nop/indexIE.htm>).

Organic Materials Review Institute (OMRI): A national, nonprofit organization that determines which input products are compliant with the National Organic Program Standards (<http://www.omri.org>). The use of OMRI-listed products requires the approval of a certifying agency. Listing of a product on OMRI lists is not a guarantee of efficacy.

Overfertilizing: Applying more fertilizer than the recommended rate. Overfertilizing may result in nutrient leaching below the root zone.

Overwatering: Applying more water than necessary to meet the crop needs and/or applying water in excess of soil water-holding capacity. Overwatering potentially results in nutrient leaching below the root zone.

Part-per-million (ppm): The ratio of one in one million: 1 ppm = 1/1,000,000. The “ppm” measurement may also represent concentrations: 1 ppm = 1 mg/L.; 1% = 10,000 ppm.

Peracetic (acid also known as peroxyacetic): A mixture of acetic acid (CH₃-COOH) and hydrogen peroxide (H₂O₂) in an aqueous solution that can be used in certified organic production as a substitute for prohibited chlorination products.

Permanent wilting point: The water content of the soil in the plant root zone when the plant can no longer extract water from the soil.

pH: A number between 0 and 14 that represents the amount of acidity (H⁺ ion concentration) in solution and calculated as: $\text{pH} = -\log[\text{H}^+]$. pH can be simply measured with a pH-meter. A solution is acidic when $\text{pH} < 7$, neutral when $\text{pH} = 7$, and basic when $\text{pH} > 7$. pH affects the solubility and ionic forms in solution. pH is the single most important chemical parameter for water or soil.

Phosphoric acid (H₃PO₄): An acid often used to lower the pH of water so to increase the efficiency of chlorination. Use of phosphoric acid is prohibited in certified organic production.

Pressure: The “force” propelling water through pipes. Common static (nonflowing) pressure in irrigation systems is 20 - 70 psi (pounds-per-square-inch). Irrigation systems operate under dynamic (flowing) water pressure, which is reduced with elevation gain and friction loss caused by the water rubbing on the sides of pipes.

Pressure due to gravity (in pounds-per-square-inches or psi): This measurement may be calculated as gain (downhill) or loss (uphill) by multiplying the height of the water column in feet by 0.433. For example, if a 200-ft drip tape is laid on a field with a downhill slope of 3ft/100ft (3%), the gain in pressure due to gravity will be $200 \times 0.03 \times 0.433 = 2.59$ psi.

Pressure loss: The loss of water pressure under flow conditions caused by debris in a filter, friction in pipes and parts, and elevation changes.

Pressure rating: The maximum pressure a pipe or drip-system component is able to handle without failing. For example, Class 160 PVC pipe refers to plastic irrigation pipe with a pressure rating of 160 pounds per square inch (psi). Aluminum irrigation pipe has a pressure rating of 145–150 psi. These pressure ratings will normally be adequate for mainlines in drip-irrigation systems.

Pressure-relief valve: A valve that opens and discharges to the atmosphere to relieve the high pressure condition when pressure in a pipeline exceeds a pre-set point.

Pressure-compensating emitter: An emitter designed to maintain a constant output (flow) over a wide range of operating pressures and elevations.

Pressure-sensitive emitter: An emitter that releases more water at the higher pressures and less at lower pressures, which are common with long mainlines or terrain changes.

Pressure regulator: A device that reduces incoming water pressure for lowpressure drip systems. Typical household water pressure is up to 50–60 psi while drip systems are designed to operate so not to exceed 8–12 psi in the drip tape. Due to friction losses, pressure in the delivery pipes may be 20–30 psi, thereby requiring a pressure regulator. The important ratings of a pressure regulator are the diameter, the downstream pressure and the maximum flow allowed by the pressure regulator.

Root zone: The depth and width of soil profile occupied by the roots of the plants being irrigated.

Sand separator: A device also called hydrocyclone that utilizes centrifugal force to separate sand and other heavy particles out of water. It is not a true filter, but could be considered a pre-filter.

Screen filter: A type of filter using a rigid screen to separate sand and other particulates out of irrigation water.

Self-flushing end cap: A spring-loaded device that lets water go out at the end of the drip tape when the water pressure is less than the threshold of the cap.

Sulfuric acid (H_2SO_4): An acid often used to lower the pH of water so to increase the efficiency of chlorination. Use of sulfuric acid is prohibited in certified organic production.

Sulfur, powdered: Elemental sulfur (S) in the yellow powder form is allowed in certified organic production. It is commonly used to decrease soil pH, but this requires chemical conversion by soil microorganisms. Powdered sulfur should not be used for chlorination purposes.

Soap: Alkaline salts of fatty acids used to remove hydrophilic particles.

Strong acid: An acid that is totally dissociated in water. Common strong acids are hydrochloric acid (HCl) and sulfuric acid (H_2SO_4).

Tape-to-lateral connector: A device sometimes called a barbed adapter and that is placed at the end of the drip tape (screw end) to connect it with the lateral (snap end).

Tape-to-tape connector: A device used to repair or replace a leaking section of drip tape. The tape-to-tape connector allows two pieces of drip tape to be connected together.

Trickle irrigation: Synonym for drip irrigation.

Turbulent-flow emitter: Emitters with a series of channels that force water to flow faster, thereby preventing particles from settling out and plugging the emitter.

Uniformity of water application: A measure of the spatial variability of water applied or stored in an irrigated field down a row and across several rows. Uniformity of water application is usually expressed as a percentage, 100% representing perfect uniformity.

Venturi injector: A tapered constriction which operates on the principle that a pressure drop accompanies the change in velocity of the water as it passes through the constriction. The pressure drop through a venturi must be sufficient to create a negative pressure (vacuum), relative to atmospheric pressure. Under these conditions, fluid from the tank will flow into the injector.

Water applied: The amount of water actually applied during an irrigation cycle. For drip irrigation, it is expressed in gallons/100 feet of drip tape.

Water hardness: The sum of multi-valent ions—such as calcium, magnesium, aluminum, or iron—in solution. Hardness is expressed in mg/L of calcium carbonate equivalent, and its value is used to classify the water as soft (0–20 mg/L), moderately soft (20–40 mg/L), slightly hard (40–60 mg/L), moderately hard (60–80 mg/L), hard (80–120 mg/L) or very hard (>120 mg/L).

Water alkalinity: Ability of water to neutralize acids. Water alkalinity is based on the content of hydroxide (OH^-), carbonate (CO_3^{2-}) and bicarbonate (HCO_3^-) ions.

Water velocity: The speed at which water travels inside a pipe, usually expressed in feet/second.

Water hammer: Pressure surge that occurs because of sudden stoppage or reduction in flow or because of a change in direction of flow. Water hammer may be reduced by slowly turning water on and also by an irrigation-system design in which water velocity is less than 5 feet/second.

Weak acid: An acid that is only partially dissociated in water. Common weak acids are phosphoric acid (H_3PO_4), boric acid (H_3BO_3), acetic acid (CH_3-COOH) and citric acid [$COOH-CH_2-(COOH-C-OH)-CH_2-COOH$].

Zone: A section of an irrigation system that can be operated at one time by means of a single control valve.

References

- Clark, G.A. and A.G. Smajstrla. 2006. Treating irrigation systems with chlorine, EDIS Publication CIR1039. Available online at <http://ufdc.ufl.edu/IR00000971/00001>.
- Clark, G.A., C.D. Stanley, and A.G. Smajstrla. 2002a. Microirrigation on mulched bed systems: Components, system capacities, and management. EDIS Publication BUL245, <http://edis.ifas.ufl.edu/ae042>.
- Clark, G.A., C.D. Stanley, F.Z. Zazueta, and E.E. Albregts. 2002b. Farm ponds in Florida irrigation systems. EDIS Publication BUL257, <http://edis.ifas.ufl.edu/ae143>.
- Clark, G.A., D.Z. Haman, and F.S. Zazueta. 2005. Injection of chemicals into irrigation systems: Rates, volumes and injection periods. EDIS Publication Bul250, <http://edis.ifas.ufl.edu/ae116>.
- Florida Department of Agriculture and Consumer Services. 2005. Water quality/quantity best management practices for Florida vegetable and agronomic crops. Florida Department of Agriculture and Consumer Services, Office of Agricultural Water Policy. http://www.floridaagwaterpolicy.com/PDF/Bmps/Bmp_VeggieAgroCrops2005.pdf
- Ferguson, J. 2004a. Definition of terms used in the National Organic Program. EDIS Publication HS963/HS209. Available online at <http://ufdc.ufl.edu/IR00000275/00001>
- Ferguson, J. 2004b. General guidelines for organic crop production. EDIS Publication HS972/HS212. Available online at <http://ufdc.ufl.edu/IR00000276/00001>
- Gazula, A., E. Simonne, and B. Boman. 2007. Guidelines for enrolling in Florida's BMP program for vegetable crops, EDIS Publication HS1114/HS367. Available online at <http://ufdc.ufl.edu/IR00000492/00001>
- Haman, D.Z. and F.T. Izuno. 2003. Principles of micro irrigation. EDIS Publication AE70/WI007
- Haman, D.Z. and A.G. Smajstrla. 2003. Design tips for drip irrigation of vegetables, EDIS Publication AE260/AE093. Available online at <http://ufdc.ufl.edu/l/IR00003290/00001>
- Haman, D.Z., J.C. Capece, and A.G. Smajstrla. 1997. Irrigating with high salinity water, EDIS Publication BUL322/AE091. Available online at <http://ufdc.ufl.edu/l/IR00003289/00001>
- Haman, D.Z., A.G. Smajstrla, and F.S. Zazueta. 2003a. Media filters for trickle irrigation in Florida, EDIS Publication AE57, <http://edis.ifas.ufl.edu/wi008>.
- Haman, D.Z., A.G. Smajstrla, and F.S. Zazueta. 2003b. Screen filters in trickle irrigation systems, EDIS Publication AE61, <http://edis.ifas.ufl.edu/wi009>.
- Haman, D.Z., A.G. Smajstrla, and F.S. Zazueta. 2003c. Chemical injection method for irrigation. EDIS Publication CIR864, <http://edis.ifas.ufl.edu/wi004>.
- Haman, D.Z., A.G. Smajstrla, and F.S. Zazueta. 2003d. Fittings and connections for flexible polyethylene pipe used in microirrigation systems, EDIS Publication AE69/WI011.
- Haman, D.Z., A.G. Smajstrla, and G.A. Clark. 2003e. Water wells for Florida irrigation systems. EDIS Publication CIR803, <http://edis.ifas.ufl.edu/wi002>.
- Hutchinson, C.M., E.H. Simonne, G.J. Hochmuth, W.M. Stall, S.M. Olson, S.E. Webb, T.G. Taylor, and S.A. Smith. 2007. Potato production in Florida, EDIS Publication HS733, <http://edis.ifas.ufl.edu/cv131>.
- Kidder, G. and E.A. Hanlon. 2003. Neutralizing excess bicarbonates from irrigation water, EDIS Publication SL142, <http://edis.ifas.ufl.edu/ss165>.
- Lamberts, M. 2007. Specialty Asian vegetable production in South Florida, EDIS Publication HS740/CV139. Available online at <http://ufdc.ufl.edu/l/IR00003483/00001>.
- Lapinski, B., A. Simonne and M.E. Swisher. 2007. Small farm food safety, fresh produce: Additional resources for participants bringing food safety concepts to farms, EDIS Publication FCS8850, <http://edis.ifas.ufl.edu/fy971>.
- Mahovic, M., J. Brecht, S. Sargent, M. Ritenour, K. Schneider, A. Simonne, J. Bartz. 2002a. Fresh produce handling, sanitation and safety measures: Beans, cucumbers, eggplants, squash, peppers, sweetcorn, EDIS Publication FSHN0213/FS094. Available online at <http://ufdc.ufl.edu/l/IR00002058/00001>.
- Mahovic, M., J. Brecht, S. Sargent, M. Ritenour, K. Schneider, A. Simonne, J. Bartz. 2002b. Fresh produce handling, sanitation and safety measures: Strawberry, raspberry, blackberry and blueberry, EDIS FSHN0212/FS093. Available online at <http://ufdc.ufl.edu/l/IR00002057/00001>.

- Muñoz-Carpena, R. 2004. Field devices for monitoring soil water content, EDIS Publication BUL343, <http://edis.ifas.ufl.edu/ae266>.
- Muñoz-Carpena, R. and M.D. Dukes. 2005. Automatic irrigation based on soil moisture for vegetable crops, EDIS ABE356, <http://edis.ifas.ufl.edu/ae354>.
- Muñoz-Carpena, R. and M.D. Dukes. 2007. Irrigation Virtual Field Day. <http://vfd.ifas.ufl.edu/gainesville/irrigation/index.shtml>.
- Olson, S.M., E.H. Simonne, W.M. Stall, M.T. Momol, S.E. Webb, G.L. Leibe, T.G. Taylor, and S.A. Smith. 2007a. Cole crop production in Florida, EDIS Publication HS84, <http://edis.ifas.ufl.edu/cv122>.
- Olson, S.M., E.H. Simonne, W.M. Stall, P.D. Roberts, S.E. Webb, T.G. Taylor, S.A. Smith and J.H. Freeman. 2007b. Cucurbit production in Florida, EDIS Publication HS725, <http://edis.ifas.ufl.edu/cv123>.
- Olson, S.M., E.H. Simonne, W.M. Stall, S.E. Webb, T.G. Taylor, and S.A. Smith. 2007c. Legume production in Florida: Snapbean, Lima bean, Southernpea, Snowpea, EDIS Publication HS727, <http://edis.ifas.ufl.edu/cv125>.
- Olson, S.M., E.H. Simonne, W.M. Stall, K.L. Pernezny, S.E. Webb, T.G. Taylor, and S.A. Smith. 2007d. Pepper production in Florida, EDIS Publication HS732, <http://edis.ifas.ufl.edu/cv130>.
- Olson, S.M., W.M. Stall, M.T. Momol, S.E. Webb, T.G. Taylor, S.A. Smith, E.H. Simonne, and E. McAvoy. 2007e. Tomato production in Florida, EDIS Publication HS739, <http://edis.ifas.ufl.edu/cv137>.
- Perez, N.A., J.F. Price, W.M. Stall, C.K. Chandler, S.M. Olson, T.G. Taylor, S.A. Smith, and E.H. Simonne. 2007. Strawberry production in Florida, EDIS Publication HS736, <http://edis.ifas.ufl.edu/cv134>.
- Pitts, D.J., D.Z. Haman and A.G. Smajstrla. 2003. Causes and prevention of emitter plugging in microirrigation systems, EDIS Publication BUL 258, <http://edis.ifas.ufl.edu/ae032>.
- Runyan, C., T. Obreza, T. Tyson, B. Goodman, P. Tacker, R. Yager, J. Thomas, A. Johnson, G. Grabow, B. Smith, and S. Dennis. 2007. Maintenance guide for microirrigation systems in the Southern Region. SR Regional Water Program, <http://fawn.ifas.ufl.edu/tools/irrigation/citrus/maintenance/>.
- Simonne, A. 2007. Principles and practices of food safety for vegetable production in Florida, EDIS Publication FCS8817, <http://edis.ifas.ufl.edu/cv288>.
- Simonne, E.H. and G.J. Hochmuth. 2007. Soil and fertilizer management for vegetable production in Florida, EDIS Publication HS711, <http://edis.ifas.ufl.edu/cv101>.
- Simonne, A., J. Brecht, S. Sargent, M. Ritenour, and K. Schneider. 2005. Good worker health and hygiene practices: Training manual for produce handlers, EDIS FCS8769/FY743. Available online at <http://ufdc.ufl.edu/IR00002283/00001>.
- Simonne, E.H., M.D. Dukes, and D.Z. Haman. 2007a. Principles and practices for irrigation management for vegetables, EDIS Publication AE260/CV107.
- Simonne, E.H., W.M. Stall, K.L. Pernezny, S.E. Webb, T.G. Taylor, and S.A. Smith. 2007b. Eggplant production in Florida, EDIS Publication HS726, <http://edis.ifas.ufl.edu/cv124>.
- Simonne, E.H., W.M. Stall, S.M. Olson, and S.E. Webb. 2007c. Okra production in Florida, EDIS Publication HS729/CV127. Available online at <http://ufdc.ufl.edu/IR00003480/00001>.
- Simonne, E.H., W.M. Stall, S.M. Olson, S.E. Webb, T.G. Taylor, S.A. Smith, and R.N. Raid. 2007d. Sweet corn production in Florida, EDIS Publication HS737, <http://edis.ifas.ufl.edu/cv135>.
- Simonne, E.H., S.M. Olson, M.L. Lamberts, W.M. Stall, K.L. Pernezny, and S.E. Webb. 2007e. Sweetpotato production in Florida, EDIS Publication HS738/CV136. Available online at <http://ufdc.ufl.edu/IR00003520/00001>.
- Simonne, E.H., D.W. Studstill, R.C. Hochmuth, J.T. Jones and C.W. Starling. 2005. On-farm demonstration of soil water movement in vegetables grown with plasticulture, EDIS Publication HS1008, <http://edis.ifas.ufl.edu/hs251>.
- Smajstrla, A.G. 2005. Hose connection vacuum breakers for home backflow prevention, EDIS Publication AE258/AE113. Available online at <http://ufdc.ufl.edu/IR00001505/00001>.

Smajtrla, A.G. and B. Boman. 2002. Flushing procedures for microirrigation systems, EDIS Publication BUL 333, <http://edis.ifas.ufl.edu/wi013>.

Smajtrla, A.G. and F.S. Zazueta. 2002. Estimating crop irrigation requirements for irrigation system design and consumptive use permitting, EDIS Publication AE257/AE078. Available online at <http://ufdc.ufl.edu//IR00003716/00001>.

Smajtrla, A.G., B.J. Boman, G.A. Clark, D.Z. Haman, D.S. Harrison, F.T. Izuno, D.J. Pitts and F.S. Zazueta. 2002a. Efficiencies of Florida agricultural irrigation systems, EDIS Publication BUL 247/AE110.

Smajtrla, A.G., B.F. Castro and G.A. Clark. 2002b. Energy requirement for drip irrigation of tomatoes in North Florida, EDIS Publication BUL 289/AE044

Smajtrla, A.G., D.S. Harrison, and J.M. Stanley. 2005. Evaluating irrigation pumping systems, EDIS Publication AE24/AE122. Available online at <http://ufdc.ufl.edu//IR00001506/00001>.

Smajtrla, A.G., B.J. Boman, D.Z. Haman, F.T. Izuno, D.J. Pitts and F.S. Zazueta. 2006. Basic irrigation scheduling in Florida. EDIS Publication BUL249/AE111. Available online at <http://ufdc.ufl.edu//IR00001504/00001>.

Treadwell, D.D. 2006. Introduction to organic vegetable production. EDIS Publication HS720, <http://edis.ifas.ufl.edu/cv118>.

Zazueta, F.S., A.G. Smajtrla and G.A. Clark. 2002. Irrigation system controllers, EDIS Publication SSAGE22/AE077. Available online at <http://ufdc.ufl.edu//IR00001497/00001>.

Table 1. Estimated itemized startup fixed costs and annual operating costs for a 2-inch-diameter drip-irrigation system for 10 acres^u

Drip irrigation system components ^v	Unit Cost ^w (\$)	Quantity	Total Cost ^x (\$)	Comments
Installation Costs				
Mazzei injector	150	1	150	
Dosatron injector	2100	1	2100	2-inch-pipe diameter, 5 - 100 gpm, 2–120 PSI, 1:500–1:50 dilution ratio
Pressure gauge	15	5	60	Actual number may vary, and range of pressure needs to match the placement in the system; one should be portable
Water meter	412	1	412	2-inch-wide water meter
Water meter fittings	11	2	22	
Water filter	87	1	87	Complete unit 2-inch 250-mesh polyester element
Backflow prevention system	405	1	405	Mandated by Florida law for fertigation
Ball valves	12	4	48	Mandated by Florida law
Irrigation water main line	0.51/ft	660 ft	337	Schedule 40, 2-inch-diameter PVC pipe. Price may vary depending on supplier.
PVC fittings ^y	3.2	10	32	Fittings here refers to crosses and tees.
Solenoids valve	31	10	310	
Irrigation controller	250	2	500	Most controllers may control six zones
Pressure regulators	32	10	320	Pressure depends on position in the system; check that unit does not restrict flow.
Total fixed cost			2,683	Calculated using a mazzei injector.
Annual Costs				
Irrigation water sub main line	69	1200 ft	250	1-inch-diameter vinyl tube (lay-flat type); may be reused based on state of repair
Drip tape	105	10 roll	1050	5/8" diameter 8-mil thickness 12-inch-spacing tape
Poly-to-drip tape connectors ^z	50	3 bags of 100	150	May be re-used if collected and cleaned at end of season
Tape-to-tape connectors	50	2 bags of 100	100	May be re-used if collected and cleaned at end of season
Flush caps	75	3 bags of 100	225	Recommended to have. May be re-used if collected and cleaned at end of season
Replacement filters (screen only)	15	1	15	Frequency of replacement depends on maintenance
Total annual costs			1,790	
^u 10-acre field divided into 10 irrigation zones; each zone measures 330 x 130 square feet; shape of zones and type of crop will affect the number of rows, and thereby the number of connectors needed; Annual costs should also include pumping station maintenance, gas and oil for pumping station, and chlorination kit ^v Shipping cost of parts not included ^w Prices may vary depending on supplier ^x Costs of well and pump installation and maintenance are not included. ^y PVP pipe connection requires saw and PVC cement ^z Drip tape connection also requires knife and whole punchers				

Table 2. Water, maintenance products, fertilizer, pesticides and supplies commonly used with drip irrigation, their allowable status for certified organic production, their National Organic Program (NOP) class, and the corresponding NOP rule reference (Sources: Organic Materials Review Institute Generic Material List^z and the NOP Final Rule)

Status ^y	NOP Class ^x	Material Name	NOP CFR Rule Reference
Water			
Allowed	CT	Water, non synthetic. Levels of contaminants in crops grown with water polluted by unavoidable residual environmental contamination cannot exceed 5% of the EPA tolerance for these contaminants in conventionally grown crops.	205.105, 205.671
Drip Irrigation Maintenance Products			
Allowed	CT	Acetic acid, non synthetic. For use as a drip irrigation cleaner.	205.105, 205.601(m)
Allowed	CT	Chelates, non synthetic. Non synthetic chelates -- including amino acid, citric acid, tartaric acid and other di-and tri- acid chelates and synthetic lignin sulfonate -- are allowed.	205.105
Prohibited	CT	Chelates, synthetic. Prohibited chelating agents include DTPA, EDTA, HEDTA, NTA, glucoheptonic acid and its salts, and synthetic amino acids.	205.105(a)
Restricted	CT	Chlorine materials, synthetic. Calcium hypochlorite, sodium hypochlorite, chlorine dioxide. Flush water from cleaning irrigation equipment that is applied to crops or fields cannot exceed the Maximum Residual Disinfectant Limit under the Safe Drinking Water Act, currently 4 mg/L (4 ppm) expressed as chlorine. For use as algacide, disinfectant and sanitizer.	205.601(a)(2)
Allowed	CT	Citric acid, non synthetic. Used as a drip-irrigation cleaner and pH adjuster.	205.105
Allowed	CT	Drip-irrigation cleaners, non synthetic. Allowed non synthetic drip irrigation cleaners include acetic acid, vinegar, citric acid, and other naturally occurring acids.	205.105
Prohibited	CT	Drip irrigation cleaners, synthetic. Prohibited drip irrigation cleaners include nitric, phosphoric and sulfuric acids.	205.105(a)
Restricted	CT	Drip irrigation cleaners, nonsynthetic. Restricted nonsynthetic drip-irrigation cleaners include bleach and chlorine materials.	205.601(a)(2)
Prohibited	CT	Hydrochloric acid (muriatic), synthetic.	205.105(a)
Allowed	CT	Hydrogen peroxide, synthetic. As algacide, disinfectant, and sanitizer including irrigation system cleaning systems.	205.601(a)(4)
Allowed	CT, CP	Natural acids, non synthetic.	205.105(a), 205.206
Restricted	CT, CP	Ozone gas, non synthetic. For use as an irrigation system cleaner only.	205.601(a)(5)[F]
Allowed	CT	Peracetic acid, non synthetic. For use in disinfecting equipment.	205.601(a)(6)
Allowed	CT	pH buffers, non synthetic. Must be from a non synthetic source such as citric acid or vinegar. Lye and sulfuric acid are prohibited.	205.105
Prohibited	CT	pH buffers, synthetic. Buffers such as lye and sulfuric acid are prohibited. ^w	205.105
Prohibited	CT	Phosphoric acid, synthetic.	205.105(a)
Drip Irrigation Materials and Supplies^y			
Restricted	CT	Plastic mulches and covers, synthetic. Must not be incorporated into the soil or left in the field to decompose. Use of polyvinyl chloride as plastic mulch or row cover is prohibited.	205.206(c), 205.601(b)(2)(ii)
Restricted	CP	Mulch, synthetic. See restrictions under plastic.	205.601(b)(2)(ii) As weed barriers (i) newspapers or other recycled paper, without glossy or colored inks; (ii) plastic mulches and covers (petroleum-based other than polyvinyl chloride)
Allowed	CP	Paper, synthetic. For use as weed barriers newspapers or other recycled paper, without glossy or colored inks. ^u	205.601(b)(2)(i), 205.601(c)

Status ^y	NOP Class ^x	Material Name	NOP CFR Rule Reference
^z The OMRI Generic Material List is a compilation of the generic materials that are allowed or prohibited for use in organic production, processing and handling under the USDA National Organic Program (NOP) Rule. ^y Allowed substances include nonsynthetic materials that are not specifically prohibited by NOP Rule section 205.602. Prohibited substances are generally defined in NOP rule 205.105. The certifying agency makes final determination of whether the use of a material is allowed, restricted or prohibited. ^x NOP class: CT = crop management tool; CP = crop pest, weed and disease control. ^w Although listed as such, sulfuric acid is not a buffer (it is a strong acid). ^v Drip tapes are not listed, and are, therefore, not prohibited. ^u The water-conservation role of mulch is not mentioned in the original documents.			

Table 3. Fertilization and irrigation record keeping requirements for the Florida vegetable BMP program (all apply to drip irrigation)

Record keeping requirement	BMP title ^z	BMP number and page ^z
Fertilization		
Record or sketch where soil samples were taken within each area.	Soil testing/soil pH	26, page 79
Record date, rate of application, materials used, and method of application when liming.	Soil testing/soil pH	26
Keep the soil testing lab report for each field and crops, as well as information about the soil-testing lab and the soil-test method used (extractant name)	Soil testing/soil pH	26
Fertilizer used and dates amounts applied	Optimum fertilization management/ application	33, page 93
Irrigation		
Maintain records of well construction	Well head protection	6, page 28
Flow rate and pressure delivered by the injector and irrigation pumps(s), as well as the energy consumption of the power unit of the irrigation pump	Chemigation/fertigation	34, page 99
Record operating values of irrigation design and how they change throughout the crop. (See Table 9 for specifics.)	Irrigation system maintenance and evaluation	39, page 112
Record the flow rate, pressure delivered by the pump, and energy consumption of the power unit frequently enough to gain an understanding.	Irrigation system maintenance and evaluation	39
Keep records of irrigation amounts applied and total rainfall received. Note with an asterisk when rainfall exceeds a leaching-rainfall event.	Irrigation scheduling	40, page 115
Keep permanent records of crop history	Seasonal or temporary farming operations	49
Keep records of flooded field duration, levels, and water quality analyses	Seasonal or temporary farming operations	49
^z Page referenced in the BMP manual for vegetable crops (FDACS, 2005).		

Table 4. Determining how much water can be stored in a pond

<p>Situation: A 2-acre pond with an average depth of 10 feet is available for drip irrigation. Questions: (1) How much water (in gallons) is available for irrigation use, considering that an average of 4 feet of water needs to be left in the pond? (2) What approximate vegetable acreage can be irrigated if the crop needs an estimated 20 acre-inches of total water?</p> <p>Answer (1) Let's assume that loss of water from the pond by evaporation is compensated by rainfall. Because we need to keep a minimum of 4 feet of water in the pond, 6 feet of water (10-4 = 6) can be used from the pond. There are 6 ft x 12 inches x 2 acres = 144 acre-inches of usable water. (If 1 acre-inch = 27,150 gallons, this total corresponds to 3,909,600 gallons available for irrigation).</p> <p>Answer (2). The water in this pond will allow the use of approximately 144 / 20 = 7.2 acres-inches of water for drip irrigation. Note that these 7.2 acres represent the cropped acres, not the field surface. Acreage of successive crops needs to be cumulated. For example, a spring crop grown on 2 acres followed by a fall crop grown on 1 acre should be counted as 2+1 = 3 acres of drip-irrigated vegetables.</p> <p>Note: As explained in Section 1.7, drip-irrigation rates should be expressed in gallons/100 feet of drip tape. However, it is realistic to use acre-inches (as in the calculations above) when calculating water-storing capacity of ponds or reservoirs.</p>
--

Table 5. Determining water needed from a well based on estimated crop water use and irrigated acreage

Situation: A farmer wants to develop a drip-irrigation system for a 4-acre field. He/she also plans to buy a 3-acre adjacent property.
Question: Assuming the whole farm will be planted with drip-irrigated sweet corn, using a high-flow drip-irrigation tape (a scenario with the highest water demand), how much water will need to be available from the well?
Answer: The total potential surface will be 3 + 4 = 7 acres. Sweet corn is planted in rows 2.5 ft apart. Hence, there will be 43,560/2.5 x 7 = 121,968 ft of sweet corn row. If a 30 gal/100ft/hr, high-flow drip tape is used, the entire 7-acre farm will have a water requirement of 121,968/100 x 30 = 609 gallons/minute.
Note that if 1-acre zones are designed and irrigated sequentially, the water requirement becomes 609/7 = 87 gallons/minute for each zone. Also note that if there are 7 zones, each zone could be irrigated for a maximum length of 3 hours per day (7 zones x 3 hr/zone = 21 hours out of 24 hours per day).

Table 6. Maximum length of drip tape (feet) and maximum irrigatable field size (acre) with low- and medium-flow drip tape at a water velocity of 5-feet-per second for selected diameters of Class 160 PVC pipes

Pipe diameter (inch)	Maximum flow rate with water velocity <5 feet/second (gal/min)	Low-flow drip-tape ^z			Medium-flow drip-tape ^y		
		Max. length of drip tape (feet) ^x	Max. irrigatable area with 30-inch row spacing crop (acre) ^w	Max. irrigatable area with crops planted on 6-ft bed spacing (acre) ^v	Max. length of drip tape (feet) ^x	Max. irrigatable area with 30-inch row spacing crops (acre) ^w	Max. irrigatable area with crops planted on 6-ft bed spacing (acre) ^v
0.5	5	1,880	0.10	0.25	1,250	0.07	0.17
0.75	8	3,008	0.17	0.41	2,000	0.11	0.27
1	13	4,887	0.28	0.67	3,250	0.18	0.44
1.5	32	12,030	0.69	1.6	8,000	0.45	1.1
2	59	22,180	1.3	3.0	14,750	0.8	2.0
2.5	86	32,330	1.8	4.4	21,500	1.2	2.9
3	128	48,120	2.7	6.6	32,000	1.8	4.4
4	211	79,323	4.5	10	52,750	3.0	7.2

^z Assuming a 16 gal/100ft flow rate (0.266 gal/min/100ft) and a 100% efficiency.

^y Assuming a 24 gal/100ft flow rate (0.400 gal/min/100ft) and a 100% efficiency.

^x Estimated maximum length of drip tape at maximum flow rate, calculated by dividing pipe flow rate (gal/min) by drip-tape nominal flow rate (gal/min/100ft); the length of each drip tape should not exceed the maximum length provided by the manufacturer.

^w For bare-ground crops typically planted with a 30-inch row spacing, such as sweet corn or snap beans, 1 acre = 17,424 linear feet of row.

^v For mulched crops typically planted with a 6-foot bed spacing, such as tomato, pepper or eggplant, 1 acre = 7,260 linear bed feet.

Table 7. Water quality parameter levels for emitter-plugging potential of drip-irrigation systems (adapted from Pitts et al., 2003)

Factor	Plugging hazard based on level		
	Slight	Moderate	Severe
pH	<7.0	7.0 to 7.5	>7.5
Dissolved solids (mg/L)	<500	500 to 2000	>2000
Manganese (mg/L)	<0.1	0.1 to 0.5	>0.5
Iron (mg/L)	<0.1	0.1 to 0.5	>0.5
Hydrogen sulfide (mg/L)	<0.5	0.5 to 2.0	>2.0
Hardness (mg/L CaCO ₃)	<150	150 to 300	>300

Table 8. Components of the “prevention-is-best-medicine” maintenance plan for drip-irrigation systems^z

Component Description	
Filtration	Goal: Remove solid particles from the water. Sand filters, disc filters, screen filters or centrifugal sand separators are used to remove precipitates and solid particles (200 mesh or equivalent for screen and disk filters) (Haman et al., 2003a,b)
Chlorination	Goal: React with microorganisms in the water and precipitate ions in solution by injecting hypochlorous acid (HOCl) in the water. A 1-ppm residual Cl concentration at the end of the drip line indicates adequate reaction (Clark and Smajstrla, 2006)
Acidification	Goal: Reduce pH to around 6.5 so to increase efficiency of chlorination (Clark et al., 2005) and other precipitates. Acid injections are also used as cleaning events for non-biotics, such as scale and calcium deposits.
Flushing	Goal: Allow solid particles and precipitates to leave the drip tape by ways other than the emitters (end of drip line; Smajstrla and Boman,1999)

^zSee Table 2 for product-allowable status under the National Organic Program (NOP).

Table 9. A checklist for maintenance of a drip-irrigation system during the growing season^z

What to Check	Frequency	Compared to What	What to Look For	Possible Causes
Pump flow rate and pressures for each zone	Weekly	Design or benchmark flow rate and pressures	High flow and /or low pressure Low flow and/or high pressure	Leaks in pipelines Leaks in laterals Opened flush valves; Opened ends of laterals Closed zone valves; Pipeline obstruction Tape clogging Pump malfunction; Well problems
Pressure difference across filter	Every irrigation	Manufacturer specifications	Exceeds or is close to maximum allowable	Filter becoming clogged Obstruction in filter
Operating pressures at ends of laterals	Monthly, unless other checks indicate possible clogging	Benchmark pressures	Pressure greater than expected Pressure lower than expected	Possible clogging; High system pressure; Obstruction in tape Broken lateral; Leaks in lateral; Low system pressure
Water at lateral ends & flush valves	Bi-weekly	Water source	Particles in water Other debris	Broken pipeline Hole in filter screen; Tear in filter mesh Particles smaller than screen; Filter problem Chemical/fertilizer precipitation Algae growth; Bacterial growth
Overall pump station	Weekly	Manufacturer specification	Leaks, breaks, engine reservoir levels, tank levels	Poor maintenance Old equipment
Injection pump settings	Weekly	Calibrated setting at startup	Proper setting for length of injection time	
Overall system	Weekly	System at start up	Discoloration at outlets or ends of laterals Leaks in tape Wilting crop	Indicates possible build up of minerals, fertilizer, algae, and/or bacterial slime Pest or mechanical damage Tape off of fittings Tape blowout from high pressure Tape clogged, obstructed, or broken. Crop may also be affected by pathogens

^zMost benchmark and in-season values in this table are also BMP record keeping requirements.

Table 10. Summary of irrigation-scheduling recommendations for vegetables grown with drip irrigation

Irrigation scheduling component	Description/Comments ^z
1- Target water application rate	May be obtained from historical weather data or crop evapotranspiration (ETc) calculated from reference ET or Class A pan evaporation (Simonne et al., 2006). May also be obtained empirically (by experience). As a general guideline, target daily water applications for vegetables grown with plastic mulch should not exceed 15 - 25 gal/100ft/hr when plants are small and 70 - 80 gal/100ft/hr when plants are fully grown
2- Fine tune application with soil-moisture measurement	Maintain soil-water tension in the root zone between 8 and 15 cbar or between 9% and 12% volumetric water content (Muñoz-Carpena, 2004; Muñoz-Carpena and Dukes, 2005). Soil moisture should be determined in the morning each day before the first irrigation cycle, approximately 6 inches away from the drip tape.
3- Determine the contribution of rainfall	Poor lateral water movement on sandy and rocky soils in Florida limits the contribution of rainfall to crop water needs to (1) foliar absorption and cooling of foliage and (2) water funneled by the canopy through the plant hole. On these soils, irrigation may be needed even after a rain. When a spodic layer is present, rainwater will accumulate above it. The water table above the spodic layer will rise by approximately one foot for every inch of rain. On these soils, the contribution of rainfall should be deducted from the irrigation schedule; irrigation is not needed after heavy rains.
4- Rule for splitting irrigation	Vertical water movement in Florida's sandy and rocky soils is rapid. Irrigations greater than 12 and 50 gal/100ft (or 30 min and 2 hrs for medium flow rate) when plants are small and fully grown, respectively, are likely to push the water front and soluble nutrients below the root zone.
5-Record keeping	Irrigation amount applied and total rainfall received. Daily irrigation schedule.

^z Efficient irrigation scheduling also requires a properly designed and maintained irrigation system. Assuming 100% application efficiency, irrigation needs are increased when plastic mulch is not used.

^y Required by the BMPs.

Table 11. Additional reliable resources related to drip irrigation

Topic	Title	Reference
Drip irrigation	Principles of micro irrigation	Haman and Izuno, 2003; Haman and Smajstrla, 2003; Clark et al., 2002a
	Drip Irrigation: The BMP Era - An Integrated Approach to Water and Fertilizer Management for Vegetables Grown with Plasticulture	Simonne et al., 2003
Wells, pumps, energy	Water wells for Florida irrigation systems	Haman et al., 2003e
	Energy requirement for drip irrigation of tomatoes in North Florida	Smajstrla, et al., 2002b
	Evaluating irrigation pumping systems	Smajstrla et al., 2005
Filters	Screen filters in trickle irrigation systems	Haman et al., 2003b
	Media filters in trickle irrigation systems	Haman et al., 2003a
Fittings and connectors	Fittings and connections for flexible polyethylene pipe used in micro-irrigation systems	Haman and Clark, 2003d
	Hose connection vacuum breakers for home backflow prevention	Smajstrla, 2005
Controllers	Irrigation system controllers	Zazueta et al., 2002
System maintenance	Causes and prevention of emitter plugging in microirrigation systems	Pitts et al., 2003
	Treating irrigation systems with chlorine	Clark and Smajstrla, 2006
	Flushing procedures for microirrigation systems	Smajstrla and Boman, 2002
	Maintenance guide for microirrigation systems in the Southern Region	Runyan et al., 2007
	Neutralizing excess bicarbonates from irrigation water	Kidder and Hanlon. 2003
Irrigation scheduling	Estimating crop irrigation requirements for irrigation system design and consumptive use permitting	Smajstrla and Zazueta, 2002
	Irrigation scheduling with irrigation pans	Smajstrla et al., 2000
	Farm ponds in Florida irrigation systems	Clark et al., 2002b
	Basic irrigation scheduling in Florida	Smajstrla et al., 2006
	Field devices for monitoring soil water content	Muñoz-Carpena, 2004 Muñoz-Carpena and Dukes, 2007
	Principles and practices of irrigation management for vegetables	Simonne et al., 2007a
	On-farm demonstration of soil water movement in vegetables grown with plasticulture	Simonne et al., 2005
	Irrigating with high salinity water	Haman et al., 1997

Topic	Title	Reference
Fertigation schedule (and other UF/IFAS production recommendations)	Commercial vegetable fertilization principles	Hochmuth and Hanlon, 2000; Simonne and Hochmuth, 2007
	Cole crops (head cabbage, Cityplace Napa cabbage, broccoli, cauliflower, collard, kale, mustard)	Olson et al., 2007a
	Specialty Asian vegetables	Lamberts, 2007
	Cucurbit crops (cucumber, summer squash, winter squash, pumpkin, muskmelon, watermelon)	Olson et al., 2007b
	Eggplant	Simonne et al., 2007b
	Legumes (snapbean, lima bean, southern pea, snowpea)	Olson et al., 2007d
	Okra	Simonne et al., 2007c
	Pepper	Olson et al., 2007d
	Potato	Hutchinson et al., 2007
	Strawberry	Peres et al., 2007
	Sweet corn	Simonne et al., 2007d
	Sweetpotato	Simonne et al., 2007e
	Tomato	Olson et al., 2007e
Produce safety	Principles and practices of food safety	Simonne, 2007
	Small farm food safety and fresh produce	Lapinski et al., 2007
	Worker health and hygiene	Simonne et al., 2005
	Fresh produce handling	Mahovic et al., 2002a,b
Chemigation	Injection of chemicals into irrigation systems: Rates, volumes and injection periods	Clark et al., 2005
	Chemical injection method for irrigation	Haman et al., 2003c

Table 12. Calculating a liquid fertilizer rate for injection into the drip-irrigation system

We want to use liquid 8-0-8 to apply a rate of 1 lbs N/acre/day.
What volume of 8-0-8 is needed?

When the actual density of a liquid fertilizer is not known, it is common to assume that 1 gallon of liquid fertilizer weighs 10 lbs. Hence, there are 0.8 lbs of N in 1 gallon of liquid 8-0-8.

Hence, we need $1/0.8 = 1.25$ gallons to supply 1 lb of N when liquid 8-0-8 is used.

How much P_2O_5 is applied with that rate of 8-0-8?

Zero.

Session 5: Resource Page

Case Study Discussion

Use of Tillage in Organic Farming Systems: The Basics

<http://articles.extension.org/pages/18634/use-of-tillage-in-organic-farming-systems:-the-basics>

Illinois Extension, Free online article.

Steel in the Field – A Farmers Guide to Weed Management Tools

<http://www.sare.org/Learning-Center/Books>

SARE, Free pdf online or book for purchase.

Equipment and Tools for Small-Scale Intensive Crop Production ATTRA

<https://attra.ncat.org/attra-pub/summaries/summary.php?pub=373>

ATTRA, Free online article.

NOTES:



Small Fruit and Vegetable Production
Post-Harvest Handling;
Food Safety

Session Six
Facilitator Notebook

Session 6 – Postharvest Handling; Food Safety Facilitator Notebook

Post-Harvest Handling (30 min- Dr. Tim Coolong, Horticulture Dept., University of Georgia)

- Harvesting-examples of specifics for common crops and markets; resources for crops
- Post-Harvest Handling
 - Factors that affect shelf life; examples
 - Removing field heat-low cost options; resources for specifics
- Recordkeeping

Learning Objectives:

- Identify 5 factors that can affect shelf-life

Learning Activity (15 min)-Post Harvest Handling PowerPoint

After the webinar on Post-Harvest Handling, pull up the PowerPoint presentation -Post-harvest Handling Learning Activity. Starting on slide 3, ask the group to identify which practices are good ones. The following slide gives gold stars by the correct answers. Briefly discuss answers and why or why not they are correct. Repeat the process for slide 5 and 7.

Low Cost Cold Room Using Cool Bot for Refrigeration-Draw participants' attention to the plans for cool-bot. This is a cost effective way of cooling produce. This hand out has step by step instructions to use a room air conditioner unit for refrigeration as well as constructing a cold room.

Food Safety (45 min-Dr. Judy Harrison, Family and Consumer Sciences, University of Georgia)

- Enhancing Food Safety on Small Farms
- Self-assessment checklist and fact sheets on water, worker hygiene, worker training

Learning Objectives:

- List the 6 areas of concern for food safety on the farm

Learning Activity (30 min)-Food Safety: Water Use and Farm Worker Hygiene Fact Sheets

After Food Safety presentation is finished, ask class to find the fact sheets on Water Use and Farm Worker Hygiene in their notebooks after the power points and give them a few minutes to read them over.

Use the Gittin' There Farms case study to help with this exercise. Have the class break up into groups and ask each group to go through the Gittin' There Farms case study and find negative examples in relation to the farm's water use and worker hygiene. Try

to get the class to give examples of what the farm could do better in relation to these two topics.

Water Use

Negatives

- The farm uses well water from their home for washing produce but have not had it tested for bacteria for many years. Well water should be tested yearly.
- The well that they use to pump water is not very deep. A shallow well may cause food safety concerns due to outside contamination. Ideally the well would be 20-50 feet deep.
- The farmers use untreated surface water for irrigation. The water is pumped into the pond from the well but could still become contaminated as it sits. Surface water should be tested quarterly.

Ways to Improve

- Test their well water regularly
- Test their surface water regularly
- Drill a new well that would be deeper and yield more

Discussion Points:

- When washing items with stem scars like melons, tomatoes, etc, the temperature of the wash water should be 10 degrees F warmer than the pulp of the product to prevent possible contaminated water from being sucked into the internal part of the product through the stem scar.
- What crops would be affected by the traveling gun when pond water is used?
 - Strawberries, lettuce, arugula, other crops that are aren't always cooked before serving. These would be most impacted by potentially contaminated water.
- Since the farm is utilizing a man-made pond, what considerations need to be taken into account about the location of the pond?
 - Need to make sure pond isn't downstream from possible sources of contamination, such as livestock.
 - Need to discourage wildlife such as ducks from visiting the ponds

Farm Worker Hygiene

Negatives

- Access to bathroom/hand washing facilities is limited when they are working in the Front Field. The distance to these facilities should be less than ¼ mile.

Ways to Improve

- Provide a porta-john with handwashing station for the Front Field

Discussion Points

- Would it be ok for the farmer to just leave hand sanitizer at the Front Field for his employees to use?
 - No, they need a proper hand washing station and bathroom in order to eliminate contaminating the produce after going to the restroom.
 - It is important to provide potable water at the hand washing station, otherwise farm workers can contaminate the produce because the water was not clean

Farm Self Help Form

Have the participants work through the Farm Self Help Form in their notebooks. Have them fill in the answers based on their farm, or if they do not have a farm, have them fill in what they think the correct answer should be. The 'correct' answer for all the questions is 'no'.

Homework Assignment

- 1) Encourage the class to read over the materials about FSMA in their notebooks.
- 2) Ask the class to begin development of a basic cropping plan. Remind them they should be looking at food safety, markets, as well as the other information they have been learning (cover crops, rotations, pest management, irrigation, equipment, soil amendments, seasonality, crop selection, tillage). Ask them to bring to Session 7:
 - a. A sketch of the farm with fields and management zones (Refer to notebook for examples)
 - b. Crop characteristics worktable (Blank copy in notebook)
 - c. Field futures worktable Part A (Blank copy in notebook)

These worksheets come from – *Crop Rotation on Organic Farms – A Planning Manual*. They can download this book as a pdf free from the SARE Learning Center. Caution them that the planning procedure is good but details about soils and climate and particular crops are from the Northeast and may not be appropriate here.



Small Fruit and Vegetable Production



Session 6 Postharvest Management of Vegetables

Timothy Coolong PhD
Extension Vegetable Specialist
University of Georgia, Tifton Campus



Learning Objectives

- Identify five factors that can affect shelf life

Postharvest Storage

- Storage losses of horticultural products are higher than other agricultural products
 - High water content makes them perishable
- Although the U.S. has better infrastructure losses can still be high

Storage losses in developing countries

Commodity	Production (1000 tons)	Postharvest Losses (%)
Carrots	600	44%
Onions	6,500	15-35%
Cauliflower	1000	50%
Lettuce	-	65%

Kays and Paull, 2004. Postharvest Biology



Postharvest Costs

- Production costs are often only a portion of total costs
 - Particularly for horticultural crops
 - This needs to be considered when budgeting

Crop	Production (%)	Postharvest (%)
Snap Bean	54	46
Sweet potato	51	49
Sweet corn	49	51
Apple	44	56

Kays and Paull, 2004. Postharvest Biology

Postharvest Quality

- If you start off with poor product you can only get worse in storage
- Harvested fruit and vegetables are still living organisms
 - After harvest destructive processes are favored

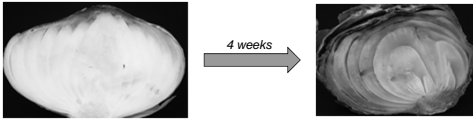


Photo: Tim Coolong

JOURNEYMAN FARMER
CERTIFICATE PROGRAM

Phytophthora in Squash



Photo: Tim Coolong

JOURNEYMAN FARMER
CERTIFICATE PROGRAM

Postharvest Quality

Constructive

- Photosynthesis

$$6\text{CO}_2 + 6\text{H}_2\text{O} \Rightarrow \text{C}_6\text{H}_{12}\text{O}_6 + 6\text{O}_2$$
- Root absorption of water and nutrients



Photo: Tim Coolong

Destructive

- Respiration
- Moisture loss
- Ethylene production
- Carbohydrate transformations
- Pectic changes (softening)
- Esters for flavor and aroma are produced
- Pigment changes

JOURNEYMAN FARMER
CERTIFICATE PROGRAM

Respiration

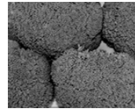
- Respiration is generally the conversion of stored sugars and oxygen to carbon dioxide and energy

$$\text{C}_6\text{H}_{12}\text{O}_6 + 6\text{O}_2 \Rightarrow 6\text{CO}_2 + 6\text{H}_2\text{O} + \text{Energy}$$
 - Lose dry matter during storage
 - Respiration rate increases with water content, oxygen levels and temperature
 - Rates typically double with an 18 °F increase in temperature

JOURNEYMAN FARMER
CERTIFICATE PROGRAM

Relative Rate of Respiration

Very High	High	Moderate	Low	Very Low
Asparagus	Bean	Beet	Cabbage	Onion
Broccoli	Lettuce	Carrot	S. Potato	Potato
Corn	Limas	Cucumber	Turnip	
Pea		Muskmelon		
Spinach		Pepper		
		S. Squash		
		Tomato		
		W. Squash		



Photos: Tim Cooling



Table: Dr. John Strang, UKY Horticulture

JOURNEYMAN FARMER
CERTIFICATE PROGRAM

Water Losses

- Horticultural products are primarily water
- Much of the weight lost in storage is water
 - High surface area = Increase water loss
 - Waxes = decrease water loss

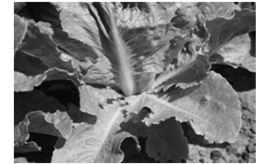


Photo: Tim Cooling

JOURNEYMAN FARMER
CERTIFICATE PROGRAM

Ethylene Production

- Ethylene is a gas that promotes ripening and other postharvest changes
 - Autocatalytic process
 - Ethylene production increases greatly in bruised and diseased fruits and vegetables
- Climacteric fruit and veggies
 - Climacteric fruits and veg. will ripen *after* harvest if picked when *mature*

JOURNEYMAN FARMER
CERTIFICATE PROGRAM

Ethylene Producing Fruit and Vegetables

Apple	Cantaloupes
Avocado	Honeydew
Banana	Hot peppers, chiles
Fig	Tomato, ripe
Mango	
Papaya	
Peach/Nectarine	
Pears	
Plums	
Persimmons	



Photo: Tim Cooling

JOURNEYMAN FARMER
CERTIFICATE PROGRAM

Ethylene Sensitive Vegetables

Arugula	Chili pepper	Parsnip
Asparagus	Cucumber	Parsley
Beans, snap	Eggplant	Peas
Broccoli	Greens	Pumpkin
Brussels sprouts	Green onion	Southern peas
Cabbage	Herbs	Squash
Carrot	Kale	Tomatillo
Cauliflower	Lettuce	Watermelon



Relatively Ethylene Insensitive Vegetables

Artichoke	Horseradish	Rhubarb
Bean sprouts	Pepper	Rutabaga
Beet	Radish	Sweet corn

Dr. John Strang, UKY Horticulture

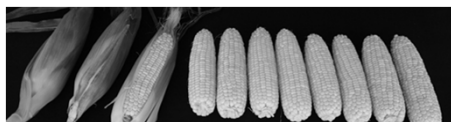


Photo: Tim Cookong



Climacteric Fruit

Climacteric

- Apple
- Tomato
- Avocado
- Banana
- Honeydew
- Pawpaw



Non Climacteric

- Pepper
- Raspberry
- Blackberry
- Watermelon
- Potatoes, onions, etc.



Photo: Tim Cookong



Carbohydrate changes

- Some produce with starches will get sweeter as it is converted to sugar-some will get starchier as small sugars are converted into starch

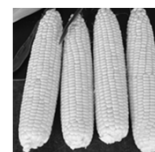


Photo: Tim Cookong



Pigment changes

- Some produce will continue to color up after harvest if harvested mature



Photo: Tim Cooling

JOURNEYMAN FARMER
CERTIFICATE PROGRAM

So how do we slow down the respiration rate, reduce acid, carbohydrate and pectin changes, as well as moisture loss ?

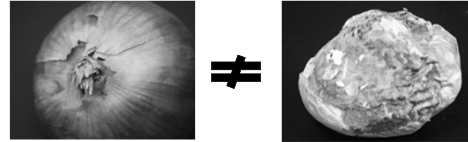


Photo: Tim Cooling

JOURNEYMAN FARMER
CERTIFICATE PROGRAM

Harvest/Rough Handling

- Careful handling of produce is essential
- Produce injury can negate all other efforts to maintain quality
- Bruising causes rates of respiration and ethylene production to increase dramatically.
- Cuts and scrapes provide a point of entry for decay-causing organisms.



Photo: Tim Cooling

JOURNEYMAN FARMER
CERTIFICATE PROGRAM

Harvest/Rough Handling

- Remove protruding nails, staples and smooth rough edges on field and harvest containers- wooden boxes.
- Harvest workers should not have long, sharp fingernails
- Use care in dumping produce from one container to another



Photo: Tim Cooling

JOURNEYMAN FARMER
CERTIFICATE PROGRAM

Harvest/Rough Handling

- Don't overfill containers! Severe damage results when stacked.
- Consider harvest time of day. Many products are more turgid in early morning and bruise more easily.



Photo: Tim Cooling

JOURNEYMAN FARMER
CERTIFICATE PROGRAM

Postharvest Handling



Photo: Tim Cooling

JOURNEYMAN FARMER
CERTIFICATE PROGRAM

Reduce produce temperature

- Harvest when produce is cool, but after dew has dried off.
- Get produce out of the sun as soon as possible.
 - For every hour after harvest that bramble fruit are not refrigerated, one day of storage life is lost.
- Cool and refrigerate as soon as possible.
 - Reducing the temp. also slows growth of disease and decay organisms.
 - Leads to produce sweating, when it is warmed up- do not warm and cool

JOURNEYMAN FARMER
CERTIFICATE PROGRAM

Effect of a Delay in Storage

- Apple softening is
 - 2X as fast at 70° F as 50° F
 - 2X as fast at 50° F as 40° F
 - 2X as fast at 40° F as 32° F
- The sooner an apple is placed in storage the longer it will maintain its quality.

JOURNEYMAN FARMER
CERTIFICATE PROGRAM



Photo: Tim Cooling

JOURNEYMAN FARMER
CERTIFICATE PROGRAM

Handling Fresh Produce

Produce	Temp. F	Rh (%)
Apples	32-40	90
Blackberries	32	90-95
Broccoli & Greens	32-35	90-95
Bell Peppers	45-50	90-95
Squash	50-55	85-90
Tomatoes, green	50-55	85-90
Tomatoes, ripe	55-60	85-90
Onions	34	75

Courtesy Dr. John Strang, UKY Horticulture

JOURNEYMAN FARMER
CERTIFICATE PROGRAM

Farmers' Market Suggestions

- Keep produce, particularly that with a high respiration rate as cool as possible prior to, in transit and at the market
 - Room with an air conditioner
 - Refrigerated truck
 - Hold in cooled ice chests prior to displaying
 - Iced produce display
- Keep produce out of the direct sun



Photo: Tim Cooling

JOURNEYMAN FARMER
CERTIFICATE PROGRAM

Building a cool room

- Some growers install an air conditioner in a trailer & insulate
 - Add a **Cool bot**
 - See attached publication
- Hydrocooler made from a milk cooler



Photo: Tim Cooling

JOURNEYMAN FARMER
CERTIFICATE PROGRAM

Learning Activity

- Identifying good post-harvest handling practices



Additional Resources

- Small-scale postharvest handling practices: A manual for horticultural crops 4th ed.

Postharvest Handling Series No. 66
Home – 2012/2013 season 2012

Small-Scale Postharvest Handling Practices:
A Manual for Horticultural Crops (4th Edition)

Lisa Klotz and Adel A. Kader



JOURNEYMAN FARMER CERTIFICATE PROGRAM

This material is based upon work that is supported by the National Institute of Food and Agriculture, U.S. Department of Agriculture, under award number 2015-70017-22861.



USDA Beginning Farmer and Rancher Development Program

Developing the Next Generation
of Sustainable Farmers in Georgia Grant





Small Fruit and Vegetable Production



Session 6 Postharvest Learning Activity



Which of the following are good post harvest handling practices?

- Careful handling of produce to prevents cuts and bruising
- Smooth harvest containers
- Containers filled to the brim to reduce the number needed
- Sharp harvest knives
- Workers trained on proper harvesting



Photo: Tim Cooling



Which of the following are good post harvest handling practices?

- Careful handling of produce to prevents cuts and bruising ★
- Smooth harvest containers ★
- Containers filled to the brim to reduce the number needed
- Sharp harvest knives ★
- Workers trained on proper harvesting ★



Photo: Tim Cooling

JOURNEYMAN FARMER CERTIFICATE PROGRAM

Which of the following are good post harvest handling practices?

- Leave produce in containers in the sun at end of row and pick up at the end of the day
- Harvest when produce is cool, but after dew has dried off.
- Cool and refrigerate as soon as possible.



Photo: Julia Gaskin

JOURNEYMAN FARMER CERTIFICATE PROGRAM

Which of the following are good post harvest handling practices?

- Leave produce in containers in the sun at end of row and pick up at the end of the day
- Harvest when produce is cool, but after dew has dried off. ★
- Cool and refrigerate as soon as possible. ★



Photo: Julia Gaskin

JOURNEYMAN FARMER CERTIFICATE PROGRAM

Which of the following are good post harvest handling practices?

- Storing broccoli and greens at 32 to 35 °F
- Storing ripe tomatoes below 55 °F
- Storing squash at 50 to 55 °F



Photo: Tim Cookling

JOURNEYMAN FARMER
CERTIFICATE PROGRAM

Which of the following are good post harvest handling practices?

- Storing broccoli and greens at 32 to 35 °F ★
- Storing ripe tomatoes below 55 °F
- Storing squash at 50 to 55 °F ★

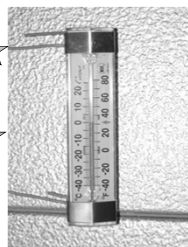


Photo: Tim Cookling

JOURNEYMAN FARMER
CERTIFICATE PROGRAM

Five Factors that Affect Shelf Life

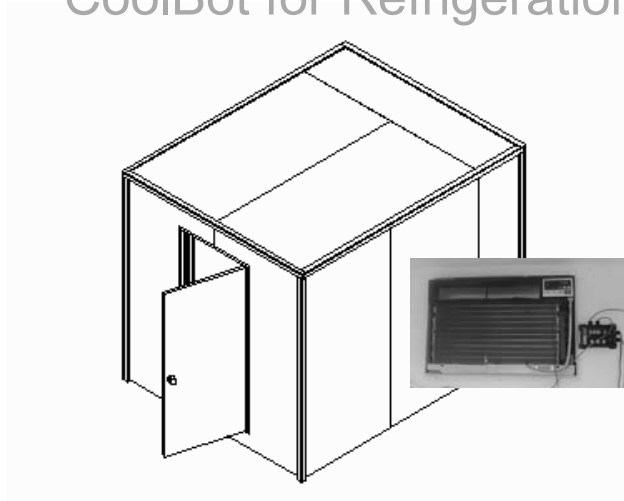
- Harvest handling
- Reduce field heat
- Proper temperature
- Ethylene sensitivity
- Surface area of crop



Photo: George Boyhan

JOURNEYMAN FARMER
CERTIFICATE PROGRAM

Low Cost Cold Room Using CoolBot for Refrigeration



2012 Mid-Atlantic Fruit & Vegetable Convention
John Wilhoit, Extension Specialist
Biosystems & Agricultural Engineering Department
University of Kentucky

Room Air Conditioner Unit Used for Refrigeration

- Advantages
 - ◆ Low cost
 - ◆ Easy to install

- Disadvantages
 - ◆ Coils will freeze up if you attempt to cool below about 60° F
 - ◆ Makeshift way to overcome this problem (using strip heaters, a thermostat, and a timer to create a defrost cycle) is cumbersome to rig up and hard to maintain

“CoolBot” control unit overcomes limitations of using air conditioner for refrigeration

- Available from *Store it Cold, LLC*¹ for about \$300
- Prevents freeze up by cycling the compressor on and off based on sensor readings of room temperature and frost on the cooling coils and by “fooling” the air conditioner’s temperature sensor with a tiny micro-heater
- Can cool down to 33° F with sufficient capacity air conditioner
- Simple digital controls and readout
- Very simple to install

¹Mention or display of a trademark, proprietary product, or firm in text or figures does not constitute an endorsement and does not imply approval to the exclusion of other suitable products or firms.

The screenshot shows the website for the Maine Organic Farmers and Gardeners Association. The header includes the organization's name, a navigation menu (Home, Programs, Agricultural Services, The Fair, Certification, Events, Publications, Resources, Store, Support MOFGA, Contact, MOFGA.net, Search), and a date of February 1, 2012. The main content area features an article titled "The CoolBot: The Small Farmer's Answer to Cold Storage" by Phil Norris. The article text describes the CoolBot as an electronic device that "fools" an air conditioner into thinking the room is warmer than it is, allowing for better cold storage. A photograph of the CoolBot device is shown, displaying a digital readout of 75.73 F. The article also includes a sidebar with a quote from Ka Memong Patayan, a "Join" button, and a link to "The Maine Organic Farmer & Gardener" magazine.

The Coolbot™ - Appropriate Cooling Technology

Temperature control is the most important factor in reducing postharvest losses

In much of the developing world, postharvest losses are as high as 80% and the cold-storage chain is virtually non-existent due to the high cost of equipment and spotty electricity. Because fresh produce can perish in a matter of days under ambient temperatures, temperature control alone can extend the shelf life by weeks or even months (Table 1).

- Quickly lowering produce temperature after harvest extends shelf life by reducing metabolic activity and microbial growth
- Market prices rise and fall drastically (Graph 1). Farmers who can store produce longer can take advantage of better prices.

The Coolbot™ provides inexpensive cold storage to developing-world farmers

The Coolbot™

1. was developed in the United States as an inexpensive way for smallscale producers to cool product on their farms
2. overrides the air conditioner's temperature gauge, tricking it into working harder
3. converts an insulated room and inexpensive, readily available window air conditioner into a coolroom
4. substantially reduces the cost of a cool storage environment for horticultural produce
5. makes cold storage a viable option for developing-world farmers, cooperatives and market groups

Basic Costs:

Coolbot™	\$299	Insulated Room	\$200
Air Conditioner	\$130	Electricity	\$200*

*subject to variations

Benefits:

- Farmers can sell produce in the offseason when prices are higher
- Farmers are protected from erratic market prices
- Increasing cold storage possibilities will stabilize fruit and vegetable prices, enabling consumers to eat healthier all year

Next Steps:

- Work with local groups to determine the cost-benefit of the Coolbot™ under various settings and the viability of using solar energy to power the system in regions that lack reliable electricity
- Identify conditions where the Coolbot™ will be most profitable

Developed by Mark Bell, Michael Reid, Peter Shapland and Amanda Crump

Resources:

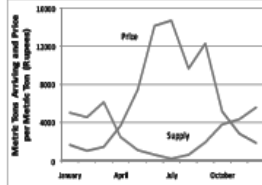
UC Davis Postharvest Technology Center | Kader, A. (2006) The Return on Investment in Postharvest Technology for Assuring Quality and Safety of Horticultural Crops | Kader, A. (2002) Postharvest Technology of Horticultural Crops. Oakland: University of California, Division of Agriculture and Natural Resources Publication, 3333, P. 585. | The Coolbot™ is a product of Store-It-Cold - <http://storeitcold.com/>

Table 1. Shelf life of horticultural products under optimum temperatures.

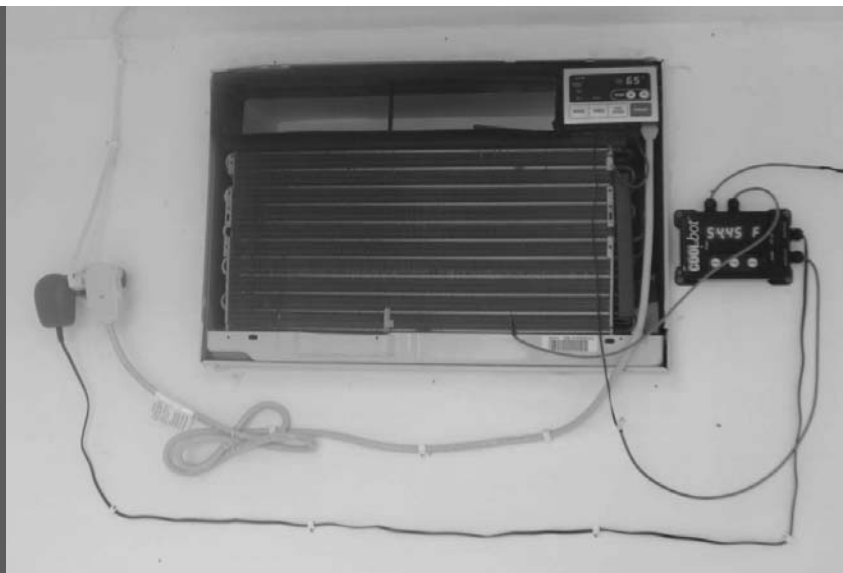
Product	Optimum Temp. (°C)	Shelf Life (Days)
Tomato	12.5	14
Mango	13	28
Banana	13	28
Bell Pepper	7.5	35
Cabbage	0	42
Potato	4	140
Lemon	13	180
Apple	0	245
Pungent Onion	0	260

—Adapted from the UC Davis Postharvest Technology Center's Produce Factsheets.

Graph 1. Volumes and Prices of Cauliflower in New Delhi



The Coolbot™ is a small black box that is wired into a standard air conditioner.



- Requires certain brands of air conditioners that have plastic temperature sensors (does not work metal temperature sensors)
- Use without filter and front grill on the AC unit
- Insert frost sensor into fins, free AC's temperature sensor and attach CoolBot's micro-heater to it
- Installation takes only a few minutes

Low cost cold room for using CoolBot

- Constructed from readily available building materials.
- Room measures 8 ft x 10 ft x 8 ft tall, large enough for substantial walk-in cold storage space, but small enough to fit into many existing barns or other covered storage spaces.
- Floors, walls, and ceiling constructed using 2 x 6 or 2 x 4 studs and plywood sheathing inside and out.
- Floors, walls, and ceiling insulated with batt insulation and foam board to an R-value of 19.
- Since this is a cooler, vapor barriers are to the outside (the hotter side) of the constructed walls.





- Foam board with taped joints forms vapor barrier on the outside
- Constructed with skids on the bottom so it can be dragged around, or even lifted with large forklift





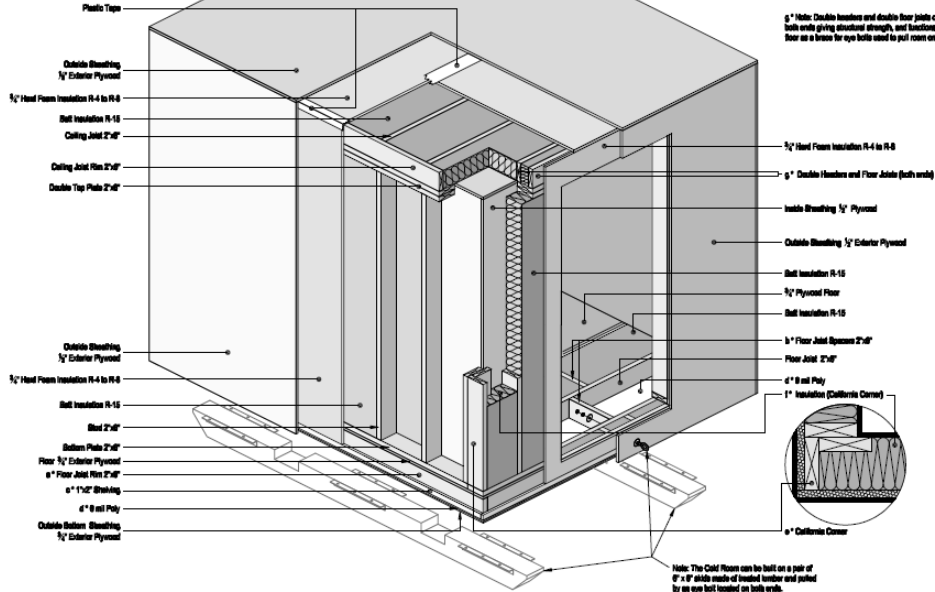
“Walk-in” space of 8’x10’x8’ tall cold room



LOW COST COLD STORAGE ROOM FOR MARKET GROWERS

NOTE: Layered Sectional Schematic of a Cold Storage Room; 8' x 8' x 10' - 2" x 8" Frame 16" on center (Size Can Vary)

Note: When faced ball insulation is used facing must be placed toward the outside wall. Open faced ball insulation can be used with hard foam insulation. Sealing the base of the corner with plastic tape creates a vapor and air barrier.



a" Note: Floor joint rim, rim and joint are 2x6" and framed 16" on center.

b" Note: Place spacers between the floor joint for support.

c" Note: Use 1"x2" shims to lift the floor joint rim supporting the ball foam insulation.

d" Note: If not poly is applied on top of outside sheathing and before floor insulation. Allow a generous overhang. This creates an air and vapor barrier substituting for the barrier the hard foam insulation creates. Foam was not used under the floor because foam compresses under weight.

e" Note: A California Corner can substitute a better insulation R - value than conventional corner, with minimal hot spots.

f" Note: Ball insulation should be finished with a corner to fit around inside corner based on a California Corner to achieve the best results. Never push ball insulation into corners. This will result in a drop in R - value and hot spots.

g" Note: Double headers and double floor joists on both ends giving structural strength, and finishing in the floor as a knee for eye bolts used to pull room on side.

Note: The Cold Room can be built on a job of 8' x 8' skids made of treated lumber and pulled by an eye bolt located on both ends.

Link to construction plans schematic at:

http://www.bae.uky.edu/ext/Specialty_Crops/plans.htm

Materials List and Cost for Low Cost Cold Storage Room
(as of June, 2009)

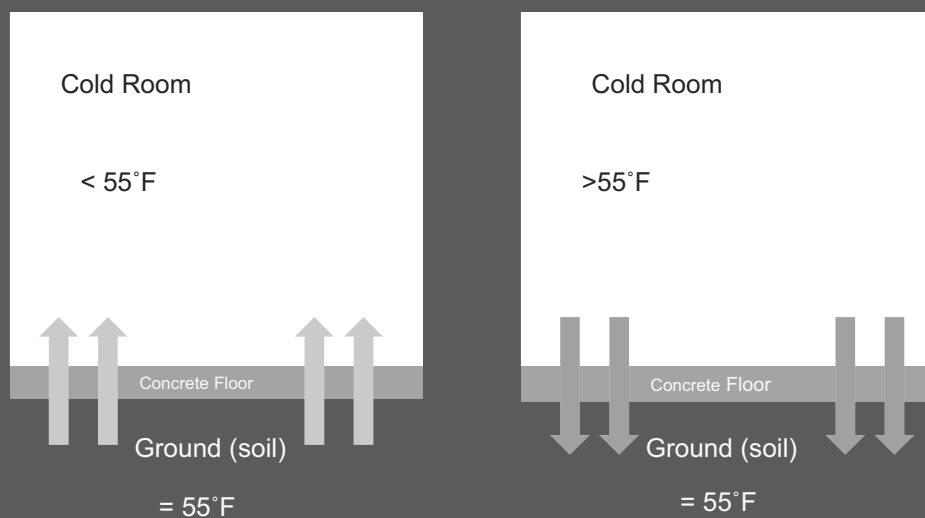
Material	Needed	Cost per 1	Cost
LUMBER			
2x6 - 8FT	62	\$3.48	\$215.76
2x6 - 10FT	11	\$4.18	\$45.98
3/4" 4x8' EXTERIOR GRADE PLYWOOD	5	\$17.20	\$86.30
1/2" 4x8' PLYWOOD SHEATHING	23	\$10.77	\$247.71
8x8" - 10' TREATED POSTS	2	\$29.97	\$59.94
SHIMS	1	\$0.99	\$0.99
THERMAL AND MOISTURE			
10x25' 8 MIL CLEAR PLY SHEETING	1	\$28.23	\$28.23
1/2IN 4x8' HARD FOAM INSULATION	12	\$10.45	\$125.40
R19 KRAFT 15IN BATTS 77.5 SQFT	7	\$29.97	\$209.97
36x80" PREHUNG INSULATED STEEL ENTRY DOOR	1	\$118.00	\$118.00
18 OZ CANNED SPRAY FOAM INSULATION	1	\$9.98	\$9.98
PLASTIC OUTLET COVER	1	\$2.25	\$2.25
FASTENERS			
1/2" x 8" GALVANIZED EYE BOLT	2	\$5.78	\$11.56
GALVANIZED 3/8" FLAT WASHER	1	\$0.13	\$0.13
GALVANIZED 1/2" ROUND WASHER	1	\$0.19	\$0.19
1-5/8" COATED EXTERIOR SCREWS (QTY in LBS)	5		\$25.64
1-1/4" COATED EXTERIOR SCREWS (QTY in LBS)	1	\$7.89	\$7.89
2-1/2" COATED EXTERIOR SCREWS (QTY in LBS)	6	\$5.59	\$33.53
1/4" x 2-1/2" GALVANIZED LAG SCREWS	50	\$0.44	\$22.00
1/4" FLAT GALVANIZED WASHER	50	\$0.09	\$5.00
3-1/4" x .131 SMOOTH SHANK NAILS 1 KEG (50lb. Box)	1	\$42.89	\$42.89
LIQUID NAILS	8	\$2.47	\$19.76
DUCT TAPE	2	\$6.49	\$12.98
BRACKETS FOR SKIDS **Built out of angle iron	12	\$5.00	\$60.00
PLASTIC CORD STAPLES	1	\$2.98	\$2.98
PAINT & FINISHES			
ACRYLIC LATEX CAULK W/ SILICONE	21	\$2.24	\$47.04
EXTERIOR WHITE PAINT (QTY in GAL)	4	\$14.99	\$59.92
PRIMER (Qty in GAL)	3	\$19.98	\$59.94
1/2" KNAP PAINT ROLLER	2	\$4.87	\$9.74
PAINT HANDLE	1	\$2.97	\$2.97
DISPOSIBLE TRAY LINER	3	\$0.64	\$1.92
METAL PAINT TRAY	1	\$2.97	\$2.97
PLASTIC PUTTY KNIFE	1	\$0.98	\$0.98
Subtotal:			\$1,576.60
SPECIALTIES			
CoolBot [®] CONTROL UNIT **Purchase Online	1	\$299.00	\$299.00
15,000 BTU ROOM A/C	1	\$399.00	\$399.00
2' EXTENSION CORD W/ 3 PLUGS	1	\$13.87	\$13.87
DOOR KNOB ASSEMBLY W/ LOCK	1	\$8.47	\$8.47
Subtotal:			\$720.34
Total: (without tax)			\$2,296.94
Tax:			\$137.82
Total: (with 6% KY tax)			\$2,434.76

Link to materials and price list at:

http://www.bae.uky.edu/ext/Specialty_Crops/

Additional considerations for low cost cold storage room construction

- Floor drain
- Floor insulation
- Alternative to batt insulation
- Alternative materials or structures
- Low-cost methods for forced-air cooling to remove field heat



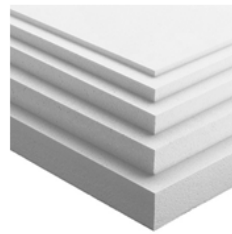
Floor Insulation important for improved efficiency if cooler used for very cold temperatures

Foam board instead of batt insulation

- Disadvantages of batt insulation
 - ◆ Loses much of its insulating value if it gets wet
 - ◆ Can harbor mold if it gets wet
- Foam board as alternative to batt insulation
 - ◆ R-value of 5 per inch thickness
 - ◆ 4 inch thickness would not fit within 2x4 stud walls
 - ◆ Estimated additional cost of \$500-600 for equivalent insulating value of batt insulation used in this cold room

Expanded Polystyrene Foam

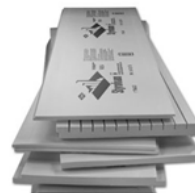
Expanded polystyrene foam (EPS) is the cheapest and least used foam board product on the market. This product typically has an R value of 3.6 to 4.0 per inch of thickness. Expanded polystyrene insulation is similar to the foam used for packing "peanuts" and it's typically used for insulated concrete forms also known as ICF's. It is also sometimes used on commercial buildings for roof and wall panel insulation which is typically sandwiched between light gauge metal.



Cost = Cheapest of the foam insulation boards.

Extruded Polystyrene Foam

Extruded polystyrene foam (XPS) also known as blue board or pink board comes in many different thicknesses and edge profiles. This insulation board is probably one of the most widely used foam board insulation products in the residential construction industry. XPS has an R value of 4.5 to 5.0 per inch of thickness.



This is the product that I typically use to insulate basement walls. It's reasonably priced, light weight and easy to use. This product is also used to insulate the outside of foundation walls and even under slabs.

Cost = This product is the middle of the road for these types of foam board insulation products.



- Low cost cold room can be made from recycled materials such as these insulated panels.
- Manufacturers (such as that make garage door panels) sometimes have scraps available at very low cost.

Different fruit and vegetables have different temperature requirements for storage

- For market growers, many items like squash, cucumbers, peppers & watermelon do best at 45-60 °F.
- Tomatoes subject to chilling injury if stored too cold (< 50 °F).
- Different fruits and vegetables also have different humidity requirements. Best to oversize AC unit if higher humidity is needed.
- HortFact-7002, “Recommended Storage Conditions for Vegetables” available at: www.uky.edu/Ag/Horticulture/comveggie.html

Recommended Storage Conditions for Vegetables

Timothy Coolong, Extension Vegetable Specialist

One size does not fit all when it comes to storing vegetables for market. Conditions that are ideal for some vegetables will lead to rapid deterioration and injury in others. The following table details the appropriate temperature, relative humidity, and expected storage life for some common vegetables. Some vegetables must be cured to improve storage shelf-life. Curing usually consists of holding vegetables at elevated temperatures to dry the outer skin on vegetables, reducing moisture loss as well as the spread of storage pathogens. Remember, only high quality vegetables should be stored, if quality is marginal prior to storage it will only worsen during storage. Vegetables showing damage and/or disease should not be stored as they may serve as a source of infection for the remainder of the stored crop.

Vegetable	Storage Temperature (°F)	Relative Humidity (%)	Average Storage Life	Curing Conditions (if necessary)
Asparagus	32-35	95-100	2-3 weeks	
Beans, green/snap	40-45	95-100	8-12 days	
Beans, lima	37-40	95-100	5-7 days	
Beets (topped)	32	95-100	3-8 months	
Broccoli	32	90-95	2-3 weeks	
Brussels sprouts	32	95-98	3-5 weeks	
Cabbage (fresh mkt)	32	95-98	3-6 weeks	
Carrot (bunched)	32	95-100	8-10 days	
Carrot (manure)	32	98-100	4-5 months	
Cauliflower	32	90-95	2-3 weeks	
Celery	32	95-100	5-6 months	
Collards/Kale	32	95-100	1-2 weeks	
Corn (sweet)	32	95-98	4-7 days	
Cucumber*	50-55	90-95	1-2 weeks	
Eggplant*	50-55	90-95	1-2 weeks	
Garlic	32	60-70	6-9 months	
Kohlrabe	32	95-100	2-3 months	
Lettuce	32	98-100	2-3 weeks	
Melons				
Canary*	50	90-95	2-3 weeks	
Cantaloupe*	35-45	90-95	1-2 weeks	
Honey Dew*	40-45	90-95	1-2 weeks	
Watermelon*	50-55	90-95	2-3 weeks	
Okra*	45-50	95	1-2 weeks	
Onion (green)	32	95	3-4 weeks	

<http://www.uky.edu/Ag/Horticulture/HortFact7002.pdf>



•Old or defunct cold storage structures can be refurbished at very low cost using the CoolBot for refrigeration.

FORCED-AIR COOLING TO IMPROVE BERRY QUALITY & SHELF-LIFE

Craig Kahlke, Area Extension Educator - Fruit Quality Management, Lake Ontario Fruit Program – Niagara County Cornell Cooperative Extension, 4487 Lake Ave., Lockport, NY 14094

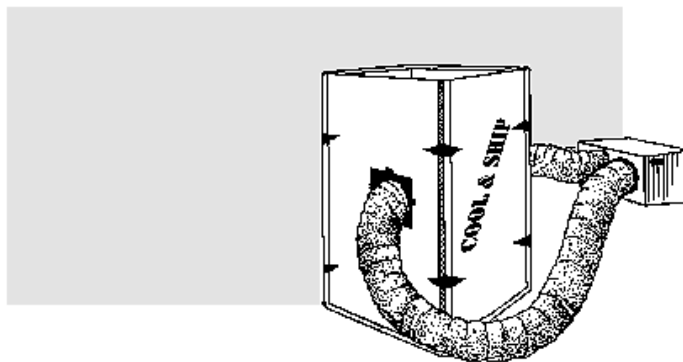
Berries are an extremely perishable crop, mainly due their brittle nature and high respiration rates. This is especially true of raspberries and strawberries, while blueberries, currants, and gooseberries are somewhat hardier. For every one hour delay in cooling of fruit after harvest, it is estimated that your produce will lose one day of shelf-life. Therefore it is critical to remove field heat from your fruit as quickly and efficiently as possible. If you put a pallet of strawberries in a 33 F cooler right after harvest, it will take approximately 9 hours for the temperature to get within 3 F of your cooler temperature. If you set up an inexpensive forced-air cooling unit (Figure 1), that same pallet of fruit will be cooled in around 90 minutes.



Figure 1. An inexpensive, home -made, forced-air cooling set up.



Figure 2. A container for use in forced-air cooling. Note adequate air holes on all sides, and nesting ability.

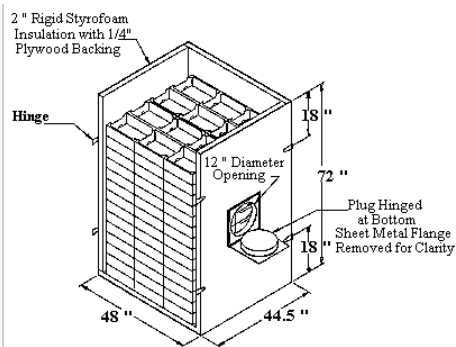
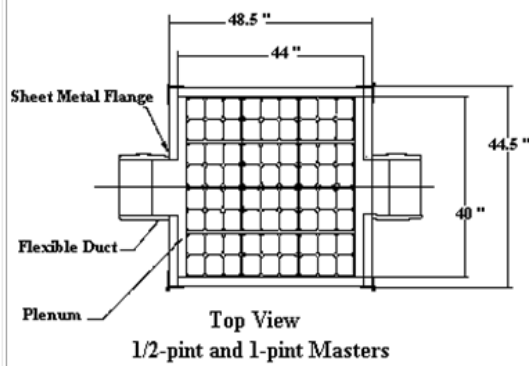
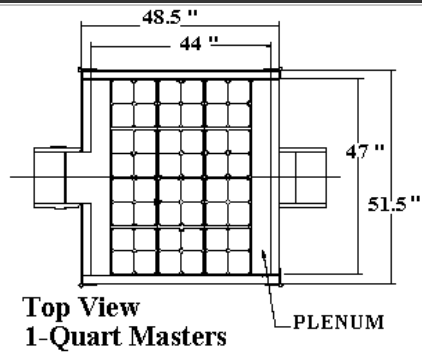


**Maintaining
the Quality of
North Carolina
Fresh Produce**

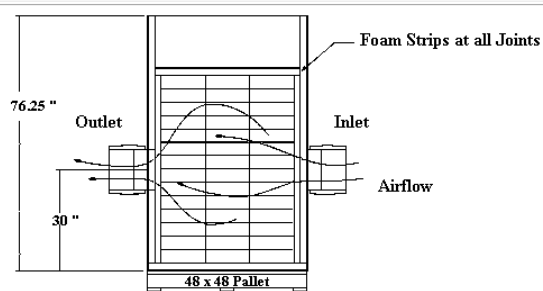
COOL AND SHIP: A LOW-COST, PORTABLE FORCED-AIR COOLING UNIT

NC State extension publication available at:

[http:// www.bae.ncsu.edu/programs/extension/publicat/postharv/ag-414-7/index.html](http://www.bae.ncsu.edu/programs/extension/publicat/postharv/ag-414-7/index.html)



Pictorial View
Top and One Side Removed for Clarity



Section View
Note: All dimensions are in inches

Extension Biological and Agricultural Engineering North Carolina State University Raleigh, North Carolina		
Cool and Ship Container		
NSA	No. 8008	Sheet 1 of 1



Small Fruit and Vegetable Production



Session 6 Growing and Selling Safe Produce

Judy A. Harrison, Ph.D.
Professor and Extension Foods Specialist
University of Georgia



Learning Objectives

- List the 6 areas of concern for food safety on the farm

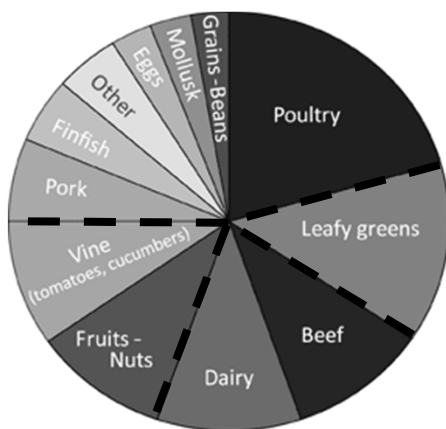
Foodborne illness in the US Each Year



- 1 out every 6 Americans
- 128,000 hospitalizations
- 3,000 deaths

Centers for Disease Control and Prevention, 2011

Causes of Foodborne Illness Outbreaks

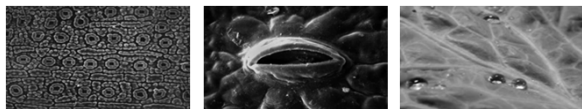


Causes of illness in 1,565 single food commodity outbreaks, 2003–2008.
(46% of illnesses from produce)

2011. www.cdc.gov/foodborneburden/cdc-and-food-safety.html and *Emerging Infectious Diseases*.
March 2013.
www.cdc.gov/eid. Vol. 19, No. 3.

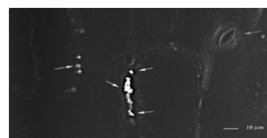
Why are there so many problems with produce?

- Once produce is contaminated, it's difficult, if not impossible to remove contamination

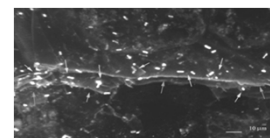


Courtesy of Dr. Joseph Frank, University of Georgia
Dept. of Food Science and Technology

JOURNEYMAN FARMER
CERTIFICATE PROGRAM



E. coli O157:H7 attached to a break in the waxy cuticle on lettuce leaf surface



E. coli O157:H7 on the cut edge of lettuce leaf

Courtesy of Dr. Joseph Frank, University of Georgia
Dept. of Food Science and Technology

JOURNEYMAN FARMER
CERTIFICATE PROGRAM

What's the big deal about foodborne illness?

Symptoms:

- Diarrhea
- Vomiting
- Nausea
- Abdominal pain
- Fever

Complications:

- Reactive arthritis
- Guillain-Barre syndrome
- Spontaneous abortion, stillbirths
- HUS (kidney failure)
- TTP (blood clots, can lead to stroke)
- Death



JOURNEYMAN FARMER
CERTIFICATE PROGRAM

At Risk Groups

- Infants and young children
- Elderly
- Pregnant women
- Immunocompromised individuals



JOURNEYMAN FARMER
CERTIFICATE PROGRAM

Who will be your customers?



Photo: Judy Hampton

JOURNEYMAN FARMER
CERTIFICATE PROGRAM

What if I make someone get sick?... Liability

Illness Severity	Court Cases with Award Information	Percent Won by Plaintiff	Average Award
Premature death	6	66.7%	\$274,580
Hospitalized & survived	60	31.7%	\$141,199
Other cases	109	29.4%	\$110,916

* Only 175 of 178 court decisions had award information. All awards are in 1998 dollars.

Buzby et. al, Economic Research Service, USDA, Agricultural Economic Report 799. www.ers.usda.gov/publications/aer799/aer799.pdf

JOURNEYMAN FARMER
CERTIFICATE PROGRAM

And what about settlements today?

Seattle Law Firm Obtains \$1.4 Million Settlement on Behalf of Salmonella Outbreak Victims

Many settlements are undisclosed...

Odwalla \$12,000,000 – \$15,000,000 *E. coli* O157:H7 settlement

Jack in the Box \$15,600,000 settlement *E. coli* O157:H7 settlement



What we've observed among farmers, market managers and consumers

It's locally grown...

I know that farmer...

It's organic...



So it's so much safer and more nutritious than what we can get at the store...



Organic Vegetables Photo 1231677 Bev Lloyd Roberts istock photo.com



But the reality is...

- Any produce, whether organically grown or conventionally grown, whether from your own back yard or thousands of miles away, can be contaminated if it is not handled properly all the way from the farm to the market.



What exactly do we mean by foodborne illness?

- Any disease caused by food that you eat
- Illnesses caused by bacteria like *Salmonella*, *Listeria*, *E. coli* O157:H7, *Shigella*
- Illnesses caused by viruses like norovirus
- Illnesses caused by parasites like *Cryptosporidium*, *Cyclospora*, *Toxoplasma*
- Illnesses caused by parasitic protozoans like *Giardia*



Norovirus



Salmonella



E. coli O157:H7



Listeria

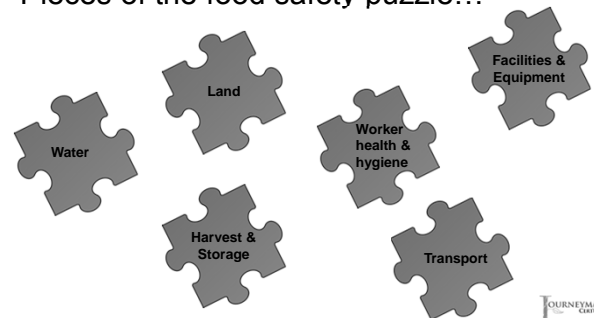


Cryptosporidium

Photos: Center of Disease Control and Prevention



Pieces of the food safety puzzle...

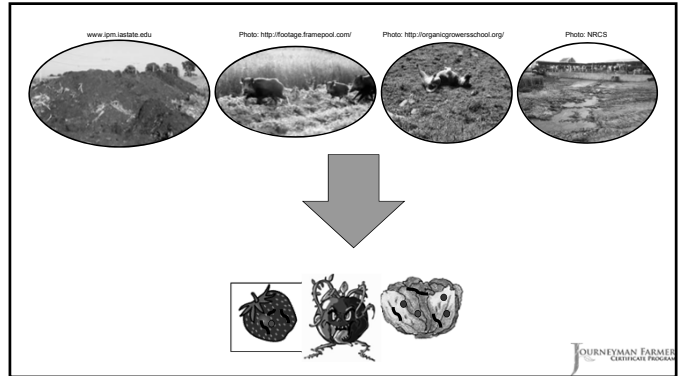


Pieces of the food safety puzzle...



- Land Use
 - Animal use?
 - Run-off?
- Manure use
 - Raw manure?
 - Composting properly to destroy disease-causing microorganisms?
- Keeping wild and domestic animals out of growing areas?

JOURNEYMAN FARMER
CERTIFICATE PROGRAM



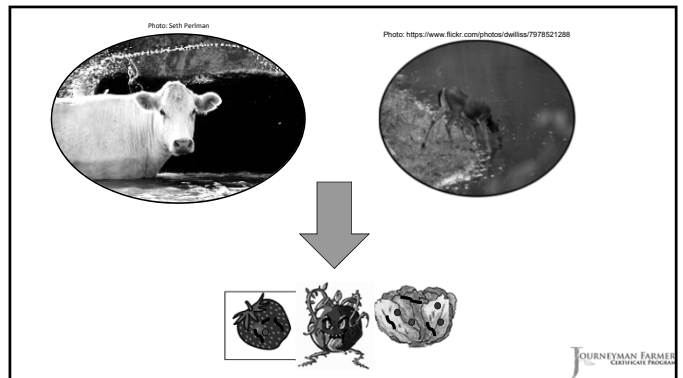
JOURNEYMAN FARMER
CERTIFICATE PROGRAM

Pieces of the food safety puzzle...



- Water Use - irrigation
 - Municipal, well water, surface water?
 - Type of irrigation method?
 - Testing plan?
- Water Use – washing produce
 - Use only potable water safe for drinking

JOURNEYMAN FARMER
CERTIFICATE PROGRAM



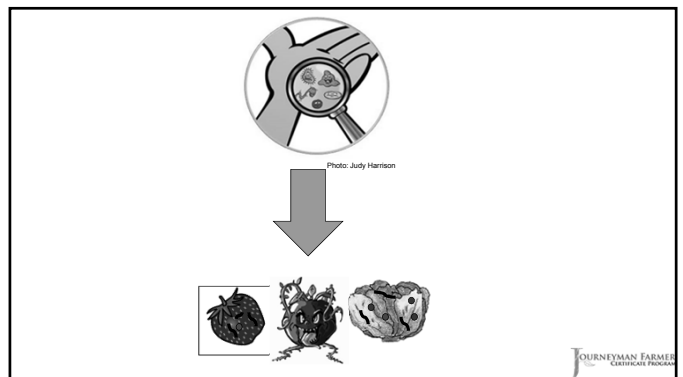
JOURNEYMAN FARMER
CERTIFICATE PROGRAM

Pieces of the food safety puzzle...



- Health
 - Avoid working with food when sick
- Hygiene
 - Clothing and hands can be a source of germs
 - Good hygiene is a MUST when working with food – including produce

JOURNEYMAN FARMER
CERTIFICATE PROGRAM



JOURNEYMAN FARMER
CERTIFICATE PROGRAM

Pieces of the food safety puzzle...



- Facilities
 - Handwashing facilities
 - Toilet facilities
 - Clean, sanitized packing and storage areas
- Equipment
 - Clean, sanitized equipment

JOURNEYMAN FARMER
CERTIFICATE PROGRAM

Photo: https://commons.wikimedia.org/wiki/File:Amish_Outhouse.jpg



JOURNEYMAN FARMER
CERTIFICATE PROGRAM

Pieces of the food safety puzzle...



- Good sanitation practices
 - Clean facilities and equipment
 - "Clean" clothes and hands
- Handling to prevent damage
- Cooling quickly to remove field heat

JOURNEYMAN FARMER
CERTIFICATE PROGRAM

Photo: hollylucon.com/?p=687

Photo: Vermont Valley Farm

Photo: Judy Harrison



JOURNEYMAN FARMER
CERTIFICATE PROGRAM

Pieces of the food safety puzzle...

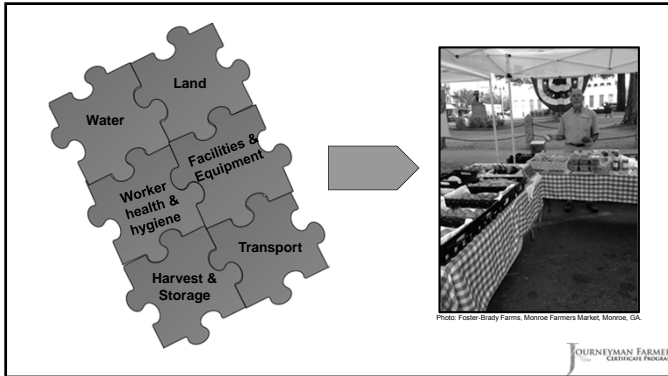


- Cool
- Covered
- Clean

JOURNEYMAN FARMER
CERTIFICATE PROGRAM



JOURNEYMAN FARMER
CERTIFICATE PROGRAM



Where to Go for Additional Resources

- County Extension Offices
- National Extension Website

To enroll in the free, on-line course, visit:
www.fcs.uga.edu/extension/enroll-produce-courses

JOURNEYMAN FARMER CERTIFICATE PROGRAM

Free On-line Course

- Practical, low cost tips for good food safety practices
- Certificate of completion that may be useful for marketing
- First step for direct marketers
- Wholesale markets will need GAPs

To enroll in the free, on-line course, visit:
www.fcs.uga.edu/extension/enroll-produce-courses

JOURNEYMAN FARMER CERTIFICATE PROGRAM

FSMA and What It Means For You

- Produce Safety Rule
 - Sets standards for water, specifies waiting periods for raw manure use, and specifies other food safety practices
 - Size of produce sales determine whether you are covered
 - \$25,000 or less in average annual produce sales not covered
 - As sales grow, compliance will be necessary
 - Compliance dates are staggered depending on annual sales of produce
 - May have as long as 4 years to comply, depending on size of sales

However, remember liability?
YOU STILL NEED TO FOLLOW BEST PRACTICES!!!

JOURNEYMAN FARMER CERTIFICATE PROGRAM

FSMA and What It Means For You

- Preventive Controls for Human Food Rule
 - Focuses on the processing of foods
 - On-farm packing and holding of produce falls under the Produce Safety Rule - not the preventive controls rule
 - Farms can do only minimal processing (such as drying grapes to make raisins, treating commodities with ethylene gas to ripen)
 - More extensive processing facilities may have to comply with preventive controls

JOURNEYMAN FARMER CERTIFICATE PROGRAM

Learning Activity

- Read and discuss Water Use and Worker Hygiene of Gittin' There Farms

JOURNEYMAN FARMER CERTIFICATE PROGRAM

Water Use

Water is an essential part of life and an essential part of any farm. It is necessary for growing produce and often for cleaning produce before it is sold. Water may also be used to protect crops from frost or to apply fertilizers or pesticides. Ensuring that you have clean water on the farm for these uses is an important part of minimizing contamination by disease-causing microorganisms called pathogens. Water can carry pathogens such as *Giardia*, *Cryptosporidium*, Norovirus, *Salmonella*, and *E. coli* O157:H7.

Irrigation water

Irrigation water usually comes from either wells or surface water sources such as ponds or streams. Municipal water is sometimes used, but this is often an expensive option. Although municipal water will minimize contamination risk, it is usually not feasible to use for irrigation. Potable well water (water safe for drinking) is also a good choice. Surface water can be used with certain precautions.

Well water – Wells can be either drilled or bored. Bored wells are usually shallow from 20 to 50 feet deep and have a larger diameter wellhead of two to three feet. They are sometimes cased with concrete and have concrete caps. Because these wells are shallow, if not properly constructed and maintained, they can have a higher potential for contamination than a drilled well. Older bored wells are vulnerable to surface water that can carry pathogens moving down the outside of the well casing or through gaps in the concrete casing created by roots from shrubs or trees.

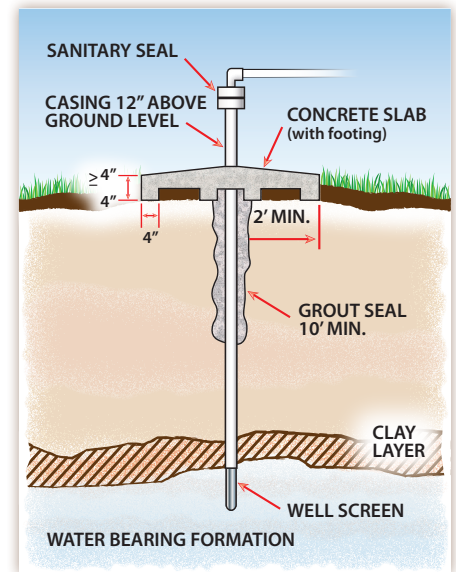
Drilled wells are usually deeper and, depending on the geology of the area, penetrate into hard rock. Because these wells are deeper, they are usually less vulnerable to contamination; however, any well that is poorly constructed and maintained can provide a conduit for pathogens into the water supply.

The wellhead location is also important for minimizing risk.

- ◆ Do not locate wellheads in areas that receive runoff from roads, heavy animal agriculture areas, manure storage areas, or composting areas.
- ◆ Do not locate wellheads within 150 feet of waste lagoons, septic tanks or drainfields.

Surface water – Ponds and streams can be used for irrigation, but be very aware of what is upstream from where water is drawn. Upstream areas that are heavily grazed or have animal access to the stream pose a higher risk of contamination.

- ◆ Exclude animals including waterfowl and pets from ponds used for irrigation water.
- ◆ Avoid using surface water after heavy rainfall until the sediments have settled, and the water is clear again. Research has shown pathogens are higher in stormwater and in sediments.
- ◆ Use drip irrigation where practical. In general, drip is preferred to overhead irrigation because the water is less likely to coat edible portions of the crop. This is particularly true when using surface water sources.
- ◆ Consider irrigating early in the day, if overhead irrigation must be used, so sunlight and drying can reduce the level of pathogens.
- ◆ Avoid overhead irrigation of produce within two weeks of harvest. This can reduce risk but is not an absolute guarantee of safety.
- ◆ Be aware that standing water in a field can be a source for pathogens, so take care to minimize its contact with the surface of produce.



▲ Diagram showing proper drilled well construction. Notice the concrete slab around the wellhead that prevents surface water from moving down the outside of the well casing. This type of slab is critical for both drilled and bored wells to prevent contamination.



▲ This well has a concrete pad to help minimize the risk of contamination.

Courtesy of Jay Payne, Cedar Grove Farm

Water testing

The most important thing that can be done to ensure the safety of irrigation water is testing for fecal coliform bacteria. Extension agents can provide containers and teach you how to take a clean sample.

Currently, there is not one single nationwide standard for irrigation water. Good examples of standards are those established by the California produce industry. According to their standards, overhead irrigation water must have a 5-sample mean *E. coli* density lower than 126 CFU/100 ml, and no sample can exceed 235 CFU/100 ml. For drip irrigation, water must have a 5-sample mean *E. coli* density lower than 126 CFU/100 ml, and no sample can exceed 576 CFU/ml. Avoid using irrigation water with these higher levels of fecal coliforms on produce that is consumed without cooking like lettuce or strawberries.

- ◆ Test well water at least once a year.
- ◆ Test surface water more often, at least quarterly.
- ◆ Keep the records of the water tests to document that you have managed your farm water as safely as possible.

Check with your local Extension office for information on agencies that test water in your state.

If well water test results indicate high fecal coliform levels, inspect the well for cracks or other damage that could allow in surface water. Once construction or maintenance problems are resolved, the well can be cleaned using shock chlorination. County Extension agents can provide information on the proper steps for this.

If surface water tests are high for fecal coliforms, evaluate potential upstream sources of contamination. Using a filter or a small settling basin can sometimes help reduce coliforms.



▲ Surface water ponds can be used for irrigation with precautions.

Produce rinsing

Many crops need an initial rinsing before they are taken to market. Greens, root crops, and some fruits are often rinsed to remove dirt. Water used for rinsing produce must be safe for drinking.

- ◆ Use drinking water from your well or a municipal source for produce rinsing.
- ◆ Never use water from streams, ponds, lakes or other surface water sources to rinse produce.
- ◆ Test well water used for produce rinsing for fecal coliforms at least once a year and keep the records.

For more information on water standards, see:

Suslow, Trevor V. Standards for Irrigation and Foliar Contact Water. Produce Safety Project Issue Brief. PEW Charitable Trusts.

www.producesafetyproject.org

Farm Worker Toilet and Handwashing Facilities

Promoting good worker hygiene is one of the most important steps farmers can take to prevent contamination of their fruits and vegetables with foodborne disease-causing microorganisms referred to as pathogens. A key step in promoting good hygiene is ensuring that there are handwashing stations and toilet facilities available on the farm in close proximity (not more than 1/4 mile) to the workers.

Setting up a good handwashing station

Thorough handwashing is a "best practice" for keeping food safe. Thorough washing will cut down on the numbers of microorganisms present which in turn helps to enhance the effectiveness of the sanitizer. Hand sanitizers should only be used after proper handwashing, not in place of it.

A good handwashing station should be equipped with the following items:

- ◆ A clean container holding potable water (water that is suitable for drinking).
- ◆ Single use paper towels.
- ◆ Hand soap or antibacterial soap.
- ◆ Trash receptacle.

Additional tips for a good handwashing station

- ◆ Use a large, closed, plastic container such as a carboy that has a spigot to hold the potable water.
- ◆ Use another large plastic container or bucket to catch the wash water.
- ◆ The handwashing station should be located close to where the workers are working in order for it to be easy for them to use.
- ◆ If your farm is large enough, house the handwashing station on a trailer so that it can be moved around your farm as the workers move from plot to plot.
- ◆ Include a sign with handwashing instructions or pictures for workers to follow. The instructions should be in English and/or Spanish or other native language.
- ◆ The station should be monitored on a regular schedule to ensure that it is clean and stocked with water, soap, paper towels etc.

Examples of handwashing stations that farmers have created on their properties



Courtesy of Wythe Morris, Virginia Tech

▲ **Picture 1.** The farmer constructed the station on a small trailer so that it can be moved around on the property. It has a sink with a faucet and mounted soap and paper towel dispensers.



Courtesy of Wythe Morris, Virginia Tech

▲ **Picture 2.** This is a simpler station, with the water container sitting on stacked pallets and a funnel collecting the wash water into a bucket underneath. A bottle of soap with a pump dispenser is on the pallet. Paper towels are stored in a covered plastic container beside the pallet.



Courtesy of Wythe Morris, Virginia Tech

▲ **Picture 3.** This station is set outside of a packing house or outbuilding and is not mobile. Here a sign with handwashing instructions is mounted below the water source.



Courtesy of Wythe Morris, Virginia Tech

▲ **Picture 4.** This is a more substantial handwashing station on a trailer which also holds the portable toilet facilities.

Setting up adequate toilet facilities

On the farm, the most common toilet facilities are rented portable toilets. One portable toilet for every 15 to 20 workers is recommended. Facilities should be located not more than a 1/4 mile walk from each hand laborer's place of work in the field.

- ◆ Facilities should be located next to or in close proximity to the handwashing station so that workers can wash hands after using the toilet.
- ◆ The portable facility can be mounted on a trailer so that it can be moved around the farm from plot to plot to make it easier for the workers to use.
- ◆ It should be serviced and cleaned on a regular basis.



Courtesy of Wythe Morris, Virginia Tech



Courtesy of Wythe Morris, Virginia Tech

Very small farm operations may have primarily family or neighbors harvesting product. In this case a home toilet is acceptable. However, single use paper towels are recommended and the toilet facilities should be serviced and cleaned on a regular basis. Going to the bathroom in the woods or other areas adjacent to growing areas should be avoided due to the risk of run-off or transfer into the fields.

This project was supported all, or in part, by a grant from the National Institute of Food and Agriculture, United States Department of Agriculture (Award Number 2009-51110-20161).

Publication #FDNS-E-168-7. R. Boyer, J.A. Harrison, J.W. Gaskin, M.A. Harrison, J. Cannon and G. Zehnder.

February 2012

The University of Georgia and Ft. Valley State University, the U.S. Department of Agriculture and counties of the state cooperating. Cooperative Extension, the University of Georgia Colleges of Agricultural and Environmental Sciences and Family and Consumer Sciences, offers educational programs, assistance and materials to all people without regard to race, color, national origin, age, gender or disability. An Equal Opportunity Employer/Affirmative Action Organization, Committed to a Diverse Work Force.



Farm Self-Help Form

<i>Practice</i>	YES	NO	DOES NOT APPLY TO ME
<i>Training & Certifications</i>			
Our farm has established food safety rules and practices.			
Our farm has completed food safety trainings and/or certification courses.			
Our farm has records of certification or evidence of training to help ensure food safety.			
<i>Land & Water Use</i>			
I know the land use history, whether the farm was previously used for livestock production or has a history of application of biosolids, septage or other by-products containing feces.			
My crop production areas are separate from or NOT located near dairy, livestock or poultry production areas or where run-off from such areas could be possible.			
If crop production areas are near or adjacent to dairy, livestock or poultry production areas, I make sure natural or physical barriers will prevent contamination of the produce growing area by wind or water.			
If I use raw animal manure, I wait at least 120 days between application and harvest for crops touching the soil and 90 days for other crops.			
I NEVER use septage or untreated human manure in crop production.			
Any composted manure I use follows the U.S. EPA or National Organic Program recommendations for temperature, turning and time to reduce disease-causing microorganisms.			
I have my well water that I use for irrigation tested for the presence of bacteria.			
I NEVER use untreated surface water (ponds, lakes, streams or springs) for overhead irrigation.			
I use municipal water or tested well water for overhead irrigation.			
I have my well water that I use for rinsing fruits and vegetables tested for the presence of bacteria.			
I NEVER use surface water (ponds, lakes, streams or springs) for rinsing fruits and vegetables.			
<i>Farm Worker Hygiene</i>			
I have policies in place to limit sick workers from coming in contact with fruits and vegetables.			
I provide sanitation training for my workers.			
I provide training for my workers on proper glove use.			
My workers have access to handwashing facilities with clean water, soap and paper towels within a short walking distance of my fields.			

<i>Practice</i>	YES	NO	DOES NOT APPLY TO ME
My workers have access to toilet facilities within a short walking distance of my packing areas.			
I train my workers to seek immediate first aid for injuries like cuts, abrasions, etc. that could be a source of contamination for produce.			
I have trained my workers on what to do with produce that comes in contact with blood or other bodily fluids.			
<i>Facilities & Equipment</i>			
Toilet facilities are serviced and cleaned on a regular schedule.			
Handwashing facilities are cleaned and stocked with clean water, soap and paper towels on a regular schedule.			
Harvesting equipment (knives, pruners, machetes, etc.) is kept reasonably clean and is sanitized on a regular basis.			
Harvesting containers and hauling equipment are cleaned and/or sanitized between uses.			
Surfaces that come in contact with fruits and vegetables at my farm are cleaned and sanitized regularly.			
Damaged containers are properly repaired or discarded.			
Any cardboard boxes used are new and only used once.			
<i>Storage & Transport</i>			
Produce is handled carefully and packed securely to prevent bruising and injury.			
I cool fruits and vegetables after harvest.			
Produce is kept cool during transport to market.			
Containers used with fruits and vegetables are cleaned and sanitized between each use.			
The vehicle is NOT used to transport animals, raw manure, chemicals or any other potential contaminant.			
The vehicle used to transport fruits and vegetables is cleaned frequently.			

If you answered “no” to any of the questions, those questions represent areas where changes or improvements may help your farm to offer safer products, attract more customers because of your commitment to food safety and reduce potential risk of foodborne illness. Please read the *Enhancing the Safety of Locally Grown Produce* factsheets for your risk area to learn how to minimize risk.

Am I affected by new
FOOD SAFETY RULES
under the
FOOD SAFETY MODERNIZATION ACT?
A Flowchart for Farmers and Food Businesses

How to Use This Flowchart:

- 1)** There are 2 sections: one for the Produce Rule and one for the Preventive Controls (Facility) Rule — these are the two main FSMA rules for businesses that grow and process food for people to eat. Start with PART 1 of each. If you find out at the end of Part 1 that you may be affected, proceed to Part 2 for details.
- 2)** FARMERS: some farms may not be subject to either rule, some farms may be subject to just the Produce Rule, and some farms may be subject to BOTH the Produce Rule and the Preventive Controls Rule. You should read PART 1 of both to be sure.
- 3)** This flowchart is intended to help you determine whether and to what extent your farm or food business MIGHT be impacted by the FSMA rules. **This is not legal advice.** Each operation is different, and your obligations under FSMA could change based on the specifics of your operation.

Timing Reminder: most farms have at least two years - until January 2018 - to come into compliance with the Produce Rule. Many smaller farms will have three or four years. And most smaller processors will have two to three years to come into compliance with the Preventive Controls (Facility) Rule (Sept 2017 or 2018).

*More FSMA Information:
<http://sustainableagriculture.net/fsma>*

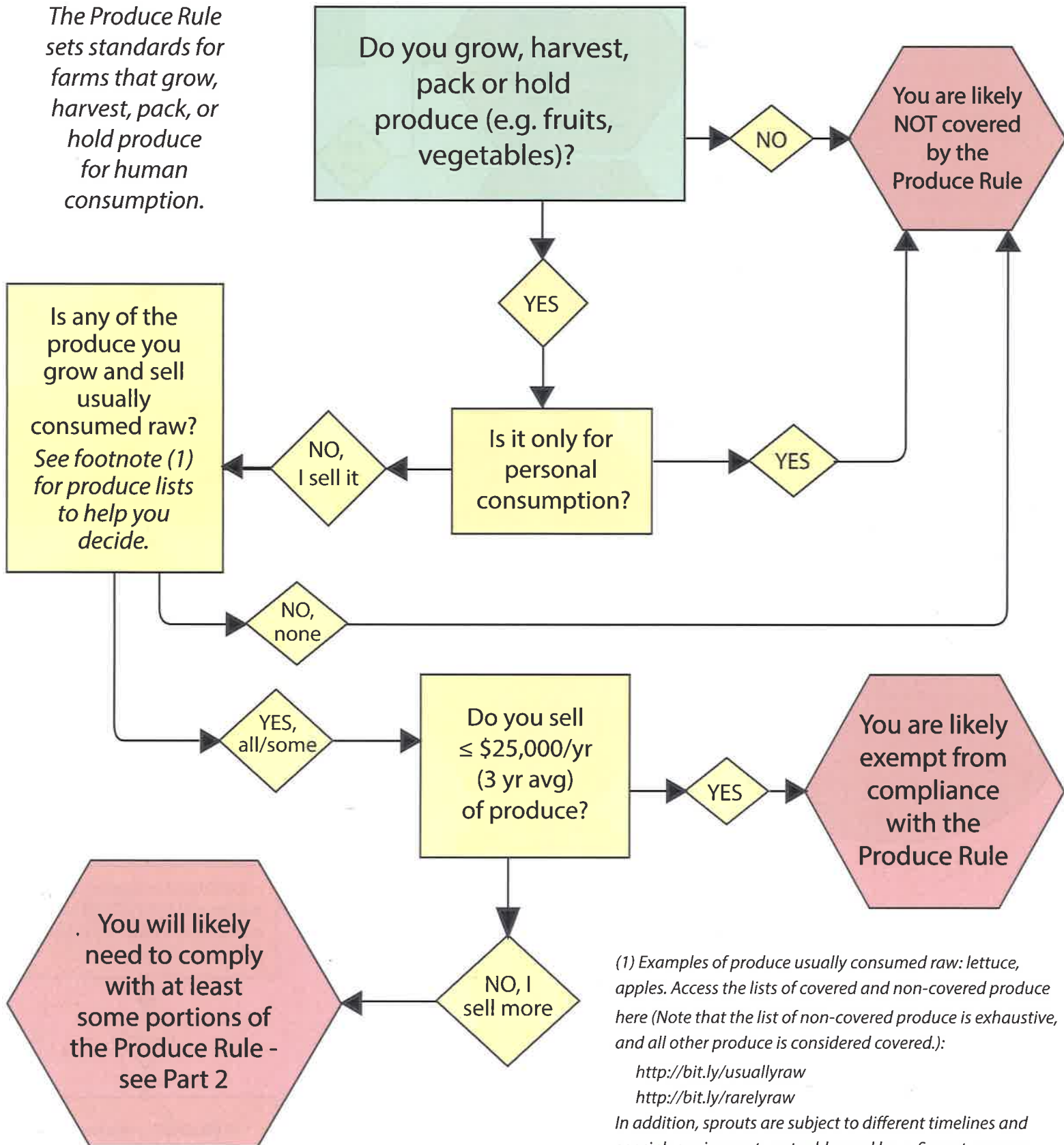


National Sustainable Agriculture Coalition

*Prepared by the National Sustainable Agriculture Coalition
February 2016*

Am I Affected by the FSMA Produce Rule?

The Produce Rule sets standards for farms that grow, harvest, pack, or hold produce for human consumption.



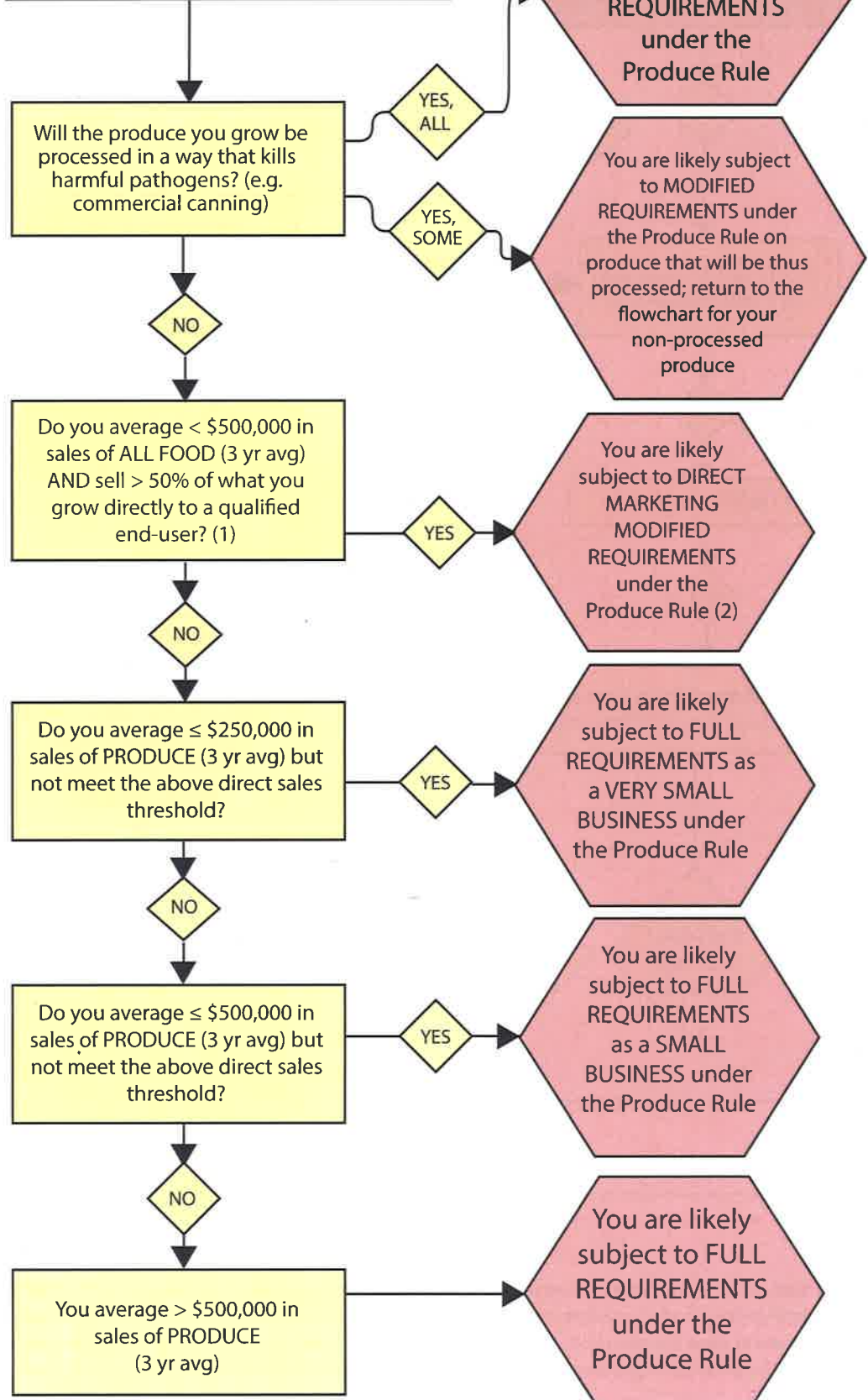
(1) Examples of produce usually consumed raw: lettuce, apples. Access the lists of covered and non-covered produce here (Note that the list of non-covered produce is exhaustive, and all other produce is considered covered.):

<http://bit.ly/usuallyraw>
<http://bit.ly/rarelyraw>

In addition, sprouts are subject to different timelines and special requirements not addressed here. Sprout growers should visit the Sprout Safety Alliance for more information: http://www.iit.edu/ifsh/sprout_safety

The FSMA Produce Rule - Part 2

So you may be covered by the FSMA Produce Rule. What does that mean?



What are MODIFIED REQUIREMENTS?

- Farms must comply with SOME Produce Rule measures under FSMA: certain recordkeeping requirements, compliance, and enforcement (3)
- Farms are NOT subject to other Produce Rule measures around water, soil amendments, etc (3)
- Farms under DIRECT MARKETING MODIFIED REQS: all of the above + must label all food at point of sale; also subject to withdrawal measures (3)

What are FULL REQUIREMENTS?

- Fully covered farms must comply with ALL Produce Rule measures: recordkeeping; worker health, hygiene, and training; soil amendments; certain water testing measures; wild and domesticated animals; buildings and equipment (4)
- SMALL BUSINESSES: 3 years to comply; 5 years for water testing (4)
- VERY SMALL BUSINESSES: 4 years to comply; 6 years for water testing (4)
- ALL OTHER BUSINESSES: 2 years to comply; 4 years for water testing (4)

1) What is a "qualified end user"? Either an individual (in any location) or a retail food establishment located in-state or within 275 miles. More details: <http://bit.ly/nsacproduce>

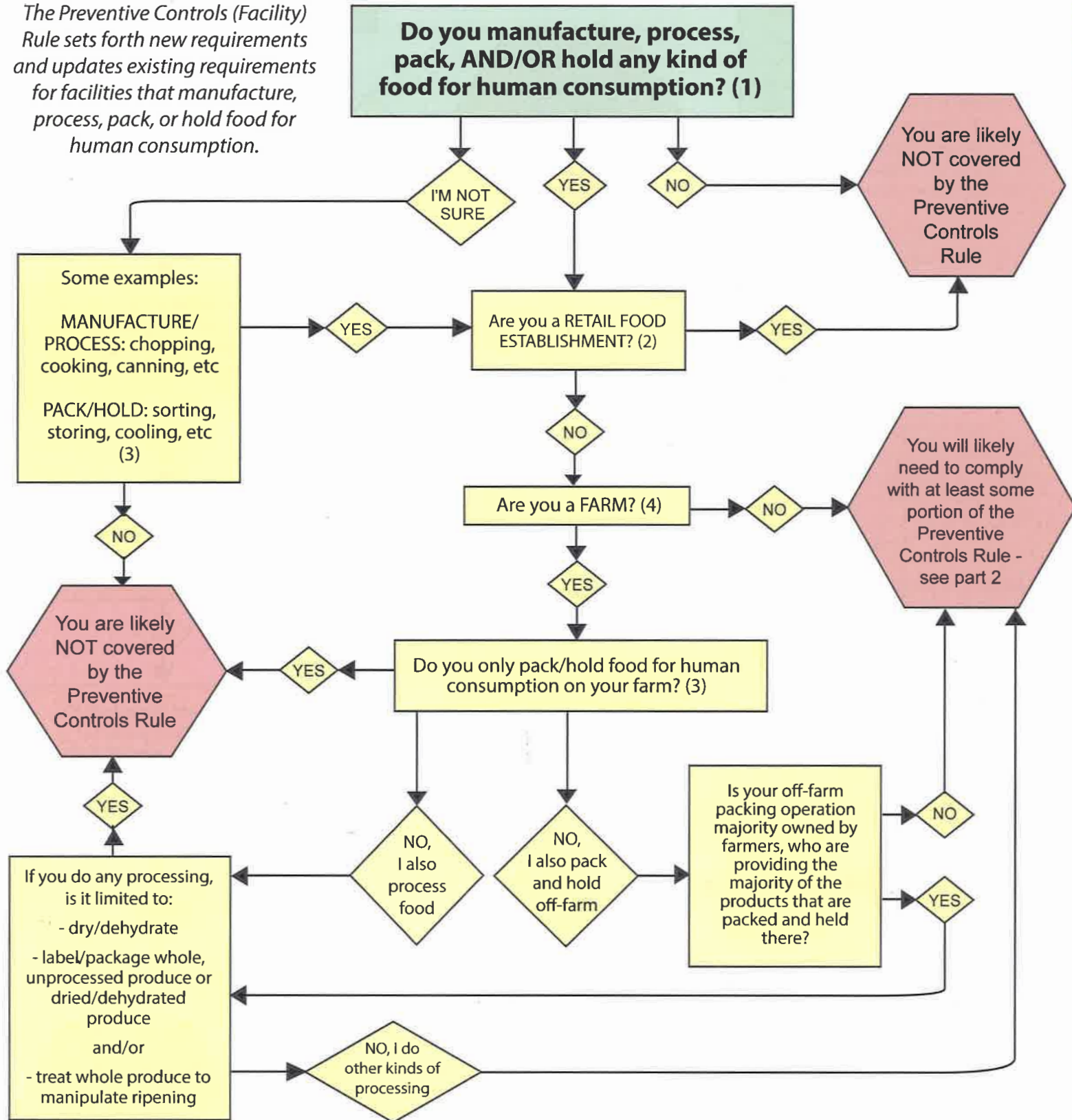
2) Direct Marketing Modified Requirements are also known as the Tester-Hagan Exemption.

3) Details on recordkeeping, enforcement, direct market labeling, and all levels of compliance: bit.ly/nsacproduce

4) Details on requirements and compliance timeframes: <http://bit.ly/fsma-pr1>

Am I Affected by the FSMA Preventive Controls (Facility) Rule?

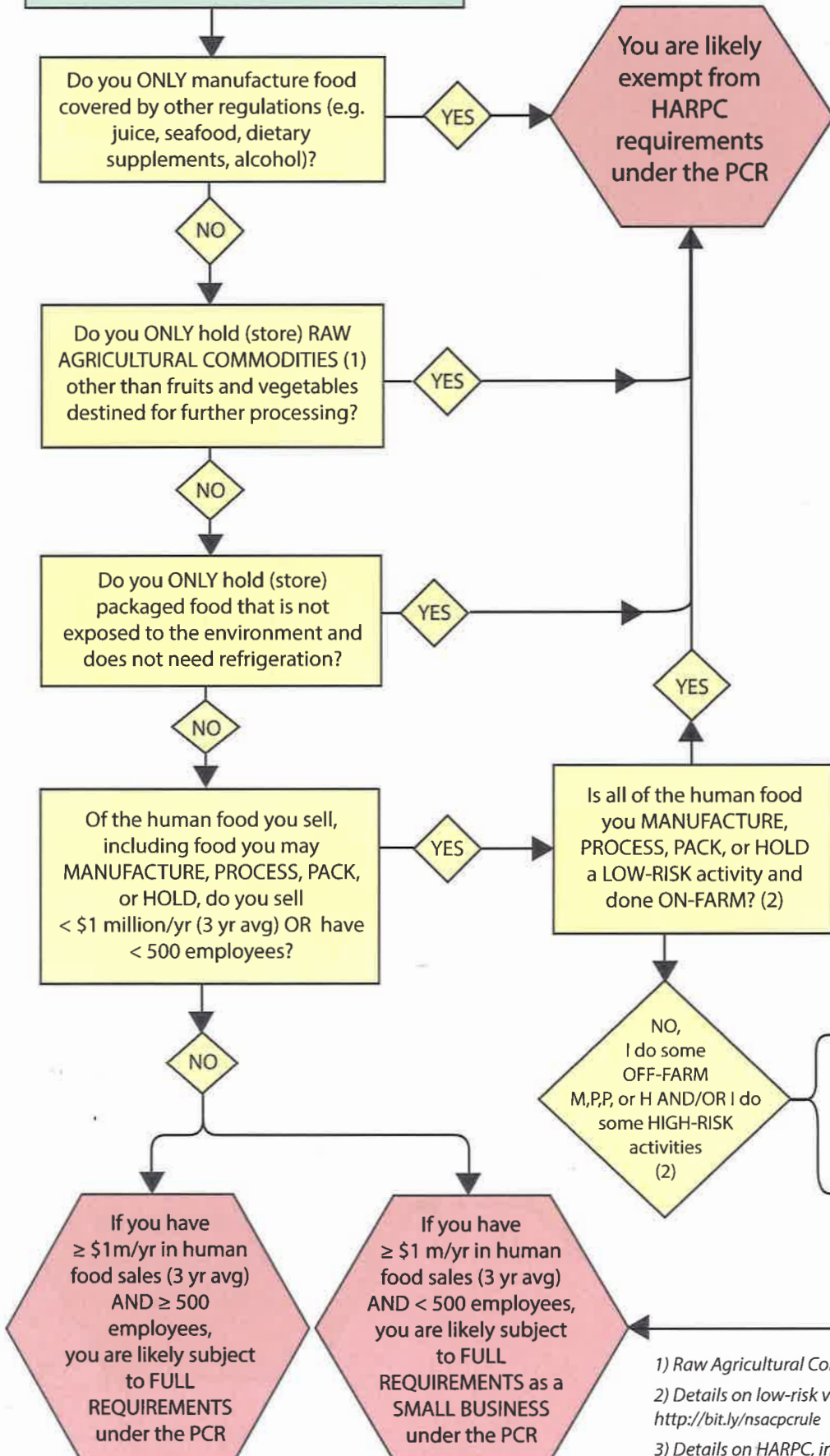
The Preventive Controls (Facility) Rule sets forth new requirements and updates existing requirements for facilities that manufacture, process, pack, or hold food for human consumption.



1) If you are manufacturing, processing, packing, or holding food **for personal consumption on farm only**, the Preventive Controls Rule does not apply.
 2) Retail Food Establishment: grocery stores, farm stands, and restaurants that sell the majority of their food directly to consumers; details: <http://bit.ly/nsacprule>
 3) Find definitions of manufacturing, processing, packing, and holding, along with examples of what "off-site" and "on-farm" mean, here: <http://bit.ly/nsacprule>
 4) Find details on FDA's "farm" definition and on packaging, labeling, dehydrating, other on-farm activities that do and don't trigger the "facility" definition: <http://bit.ly/nsacprule>

The FSMA Preventive Controls (Facility) Rule - Part 2

So you may be covered by the Preventive Controls Rule. What does that mean?



WHAT ARE PCR REQUIREMENTS?

- FACILITIES EXEMPT FROM HARPC: must register with FDA and continue complying with already-existing rules and practices (like Current Good Manufacturing Practices), but do not need to develop Hazard Analysis and Risk-Based Preventive Controls (HARPC) plans and procedures (3)

- QUALIFIED FACILITIES: must register with FDA and submit certain attestations; not required to develop full HARPC plans and procedures but must follow certain basic requirements (e.g. recordkeeping); if sales < \$1M, 3 yrs to come into compliance (3)

- FACILITIES SUBJECT TO FULL REQUIREMENTS: must register with FDA; must develop full HARPC plans and procedures laid out under the PCR; facilities have 1 year to come into compliance (3)

- FULL REQUIREMENTS as a SMALL BUSINESS: Same as above but with 2 years to come into compliance (3)

1) Raw Agricultural Commodity: a food in its raw and natural state (e.g. raw grains)

2) Details on low-risk vs high-risk activities and off-farm vs on-farm: <http://bit.ly/nsacprule>

3) Details on HARPC, including compliance timelines: <http://bit.ly/nsacprule>

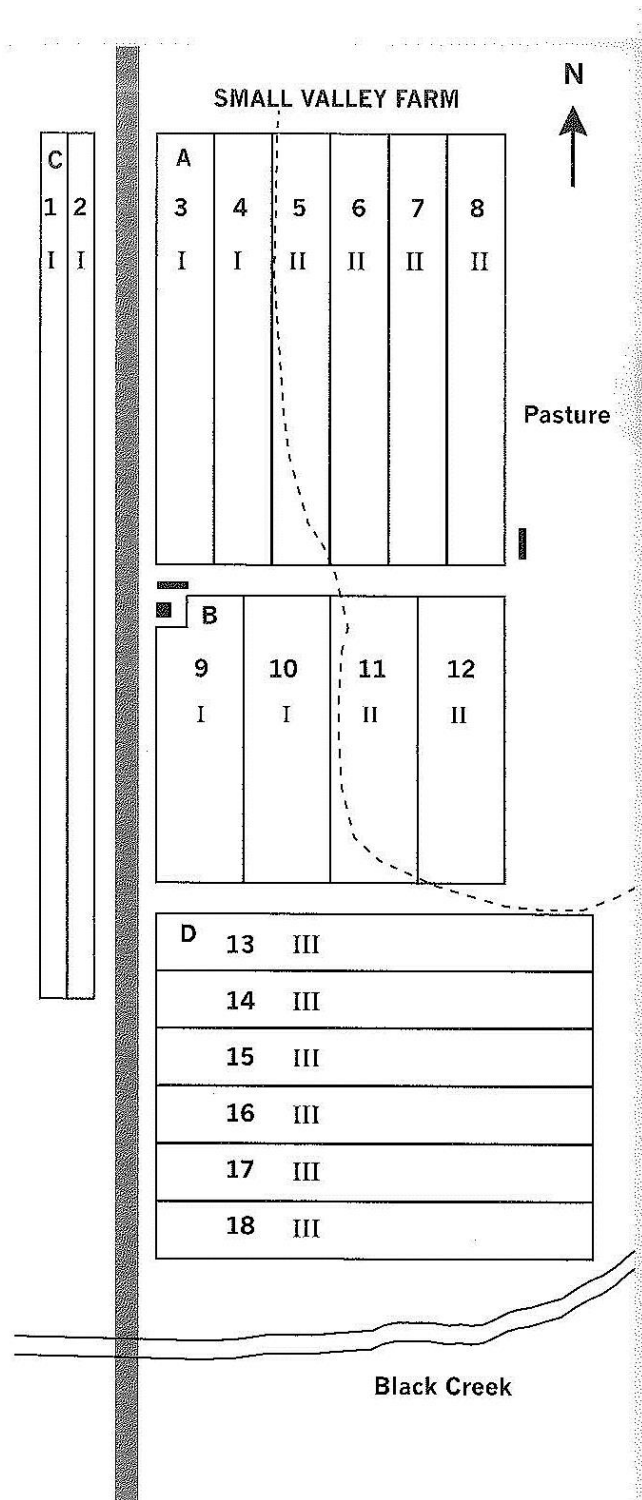


FIGURE 5.3 Map of Small Valley Farm showing location of management units. Excessive slopes occur east of the dashed line. Management units are numbered and field type is indicated by Roman numerals.

Session 6: Resource Page

Postharvest Handling

Small-scale postharvest handling practices: A manual for horticultural crops 4th ed.

Lisa Kitinoja and Adel A. Kader, University of California Davis Postharvest Technology Research and Information Center

Food Safety

FDA Food Safety Modernization Act (FSMA)

<http://www.fda.gov/Food/GuidanceRegulation/FSMA/>

UGA Extension Free Online Course-Good Food Safety Practices

www.fcs.uga.edu/extension/enroll-produce-courses

NOTES:



Small Fruit and Vegetable Production

Marketing; Crop Plans

Session Seven
Facilitator Notebook

Session 7 – Marketing; Crop Plans Facilitator Agenda

Marketing (30 min-*Teniso Seanima, Georgia Organics*)

- Requirements for direct markets vs wholesale markets
- Wholesale market needs USDA #1's, need GAP certified, consistent products and volume
- Direct to consumer have a wide variety of crops for farmers' markets or CSA, pricing

Learning Objectives:

- List three major differences between wholesale and direct sales markets

BEFORE THE WEBINAR - Ask for a volunteer to discuss their crop plan. While the webinar is playing, sketch the field and management zones on the board or large sheet of paper. Then transfer their crop characteristics worktable to another part of the board or large sheet of paper and do the same with the Field futures worktable.

Crop Plans (30 min- *David Berle, Horticulture Dept., University of Georgia*)

- Crop Plan examples for direct market and wholesale, resources for crop plans

Learning Objectives

- Alternative methods of crop scheduling
- Importance of matching crop production with market

Learning Activity (40 min) - Crop plan discussions

This is homework assignment from Session 6. You will need a blackboard or a large pad on an easel for this activity.

You can decide to spend time on one plan or ask several people to present their plans. Ask the volunteer to briefly (5 min) present the plan to class. Discuss the plan. The following questions will help guide discussion.

What is the market for this farm? Do the crops and crop mix seem appropriate for that market or markets?

Are there special considerations for particular fields or management zones? Steep slopes, wet areas, potential flooding areas. Does the crop plan address these?

How are the management zones laid out? Are the management zones equal size? If not why not? Why is this important?

Are crops put in the appropriate growing season?

Are plant families grouped? Do the same plant families follow each other in a year?

Are there cover crops incorporated into the plan? Why or why not?

What changes would you make based on ideas from Prof. Berle's webinar or input from the class?

Wrap Up (20 min)

- Hands-On Training – Take the next step
Please remind participants that if they have taken a Small Farm Business Planning training or AgAware, and successfully pass the Small Fruit and Vegetable knowledge evaluation, they are eligible to apply for a paid internship or have a Farmer Mentor assigned to consult with them on their farm to improve their operation. Pass out the Hands-On Program materials and application form.
- Online knowledge evaluation
Please pass out the link to the Online knowledge evaluation. Remind the participants that they have two weeks to complete the knowledge evaluation and may take it more than once. If they want to retake the knowledge evaluation, ask them to **PLEASE type in their first and last name each time they begin the evaluation so we can track the final score.**
- Pre/Post Test and Training Evaluation
Print out the third party evaluations and have participants fill them out. Let them know this is important feedback for us to improve the training.



Small Fruit and Vegetable Production



Session 7 Marketing

Tenisio Seanima
Farmer Services Coordinator
Georgia Organics

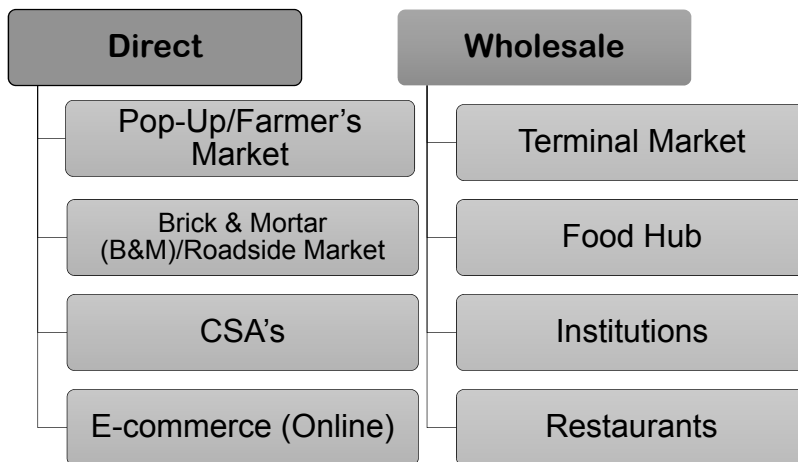


Learning Objectives

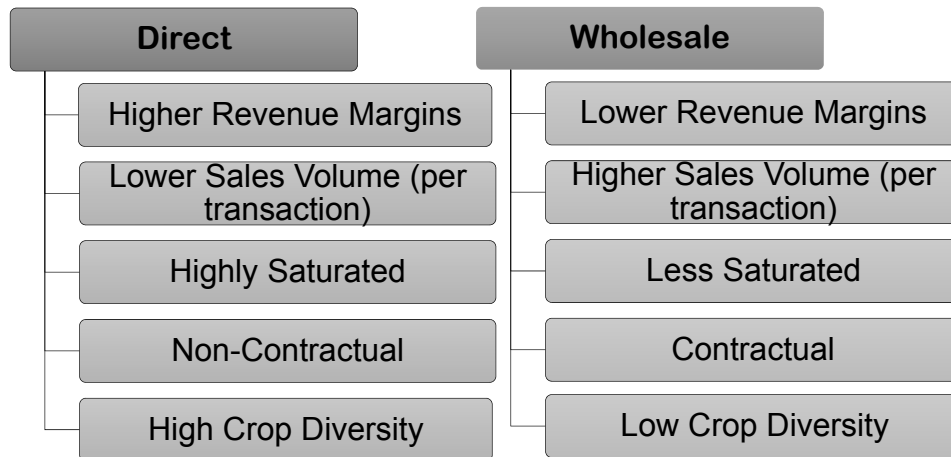
List three major differences between wholesale and direct sales markets



Direct Markets vs. Wholesale Markets



Direct vs. Wholesale cont.



Which Market Do You Go With?

Market Considerations



Market Considerations Competition

LOW	MEDIUM	HIGH
<ul style="list-style-type: none"> • Lightly compacted (Grocer, Institutions). • Greater barriers to entry. • Market-entry is costly. 	<ul style="list-style-type: none"> • Moderately compacted (Restaurant). • Moderate barriers to entry. • Market-entry is moderately priced. 	<ul style="list-style-type: none"> • Densely compacted (Farmer's Market). • Few barriers to entry. • Market-entry is low-cost.



Market Considerations Fulfillment Difficulty Level

EASY	MEDIUM	HARD
<ul style="list-style-type: none"> • Consistent inventory preferred, but not required. • Customers typically come to you. • Transactions are 100% Cash On Delivery (COD) 	<ul style="list-style-type: none"> • Consistent inventory required. • Customers either come to you or require delivery. • Transactions are COD or term-based. 	<ul style="list-style-type: none"> • Consistent inventory required. • Customers typically require delivery. • Transactions are 100% term-based.



Market Considerations

Certifications

**Certified
Naturally
Grown**



Photo Credit: [Certified Naturally Grown](#)

**Good
Agricultural
and Handling
Practices**



Photo Credit: [Bureau of Agriculture and Fisheries Standards](#)

**Certified
Organic**



Photo Credit: [United States Department of Agriculture](#)



Market Considerations

Certifications (cont.)

**Certified
Organic**

“Organic agriculture produces products using methods that preserve the environment and avoid most synthetic materials, such as pesticides and antibiotics. USDA organic standards describe how farmers grow crops and raise livestock and which materials they may use.”

“Organic farmers, ranchers, and food processors follow a defined set of standards to produce organic food and fiber. Congress described general organic principles in the Organic Foods Production Act, and the USDA defines specific organic standards. These standards cover the product from farm to table, including soil and water quality, pest control, livestock practices, and rules for food additives.”

Information Credit: [United States Department of Agriculture](#)



Market Considerations Certifications (cont.)

Certified Naturally Grown (CNG)

“[CNG] standards for produce and livestock certification are based on the standards of the National Organic Program. CNG participation requires a full commitment to robust organic practices.”

“CNG is based on the participatory guarantee system (PGS) model that relies on peer reviews in which inspections are typically carried out by other farmers. The PGS model promotes farmer-to-farmer knowledge sharing about best practices and fosters local networks that strengthen the farming community.”

“Another difference is that CNG’s certification process is transparent and open to the public. Every CNG producer has a profile on the website. On it you will find the information they submitted in their application, as well as scanned images of their inspection reports and signed declaration.”

Information Credit: [Certified Naturally Grown](#)



Market Considerations Certifications (cont.)

Good Agricultural and Handling Practices

“Good Agricultural Practices (GAP) and Good Handling Practices (GHP) are voluntary audits that focus on best agricultural practices to verify that fruits and vegetables are produced, packed, handled, and stored in the safest manner possible to minimize risks of microbial food safety hazards. GAP & GHP audits verify adherence to the recommendations made in the U.S. Food and Drug Administration’s *Guide to Minimize Microbial Food Safety Hazards for Fresh Fruits and Vegetables (pdf)* and industry recognized food safety practices.”

Information Credit: [United States Department of Agriculture](#)



Market Considerations

Product Grade Level

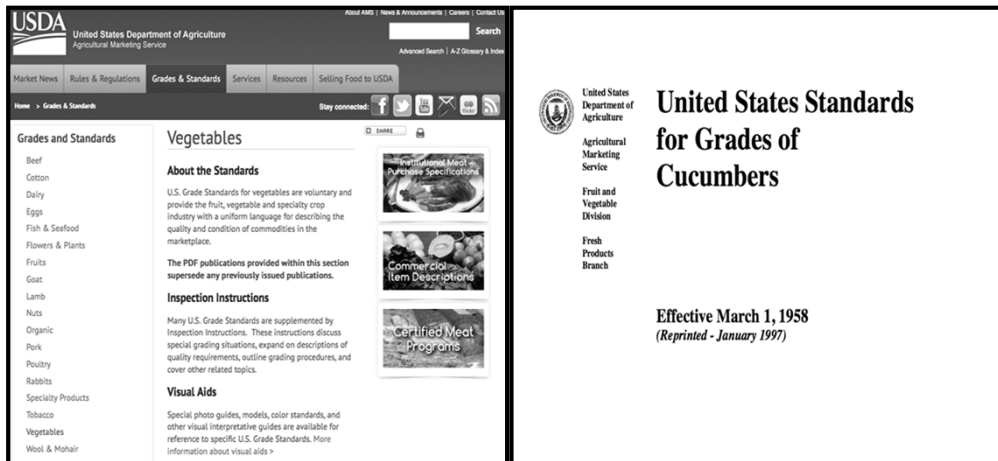


Photo Credit: [United States Department of Agriculture](#)

Photo Credit: [United States Department of Agriculture](#)



Example: Grades of Tomatoes

- **U.S. No. 1** consists of tomatoes which meet the following requirements:
 - a. Basic requirements:
 - 1. Similar varietal characteristics;
 - 2. Mature;
 - 3. Not overripe or soft;
 - 4. Clean;
 - 5. Well developed;
 - 6. **Fairly well formed; and,**
 - 7. **Fairly smooth.**
 - b. Free from:
 - 1. Decay;
 - 2. Freezing injury; and,
 - 3. Sunscald.
 - c. **Not damaged by any other cause.**

- **U.S. No. 2** consists of tomatoes which meet the following requirements:
 - a. Basic requirements:
 - 1. Similar varietal characteristics;
 - 2. Mature;
 - 3. Not overripe or soft;
 - 4. Clean;
 - 5. Well developed;
 - 6. **Reasonably well formed; and,**
 - 7. **Not more than slightly rough.**
 - b. Free from:
 - 1. Decay;
 - 2. Freezing injury; and,
 - 3. Sunscald.
 - c. **Not seriously damaged by any other cause.**

Information Credit: [United States Department of Agriculture](#)



Market Considerations Crop Diversity

DIRECT

- Higher price per pound
- Greater diversity per acre
- More hands-on labor
- Less efficient operation

WHOLESALE

- Lower price per pound
- Less diversity per acre
- More mechanized labor
- More efficient operation



Market Considerations Pricing (Categories)

STATIC PRICING (Single Price Points)

- Typically avoided due to the unpredictable nature of farming.

DYNAMIC PRICING (Multiple Price Points)

- Involves pricing in response to supply and demand pressures in real time.



Market Considerations Pricing (Research)

Industry Watch

The...Custom Average Tool (CAT) offers users a way to condense the highly detailed information provided in Fruit and Vegetable Market News reports. The tool allows users to determine average prices for any commodity available in Terminal Market, Shipping Point, and Retail reports from our entire dataset, using a variety of customizable filters. The CAT gives users the flexibility to narrow the average price selection down to a very granular range by selecting a specific location, package, unit, variety etc., or by broadening the average price range and selecting all or multiple locations, packages, varieties and other values in filter options.

USDA Custom Average Tool

Information Credit: [United States Department of Agriculture](#)



Market Considerations Packaging

RETAIL



Photo Credit: [Love Is Love Farm](#)

BULK



Photo Credit: [Atlanta Local Food Initiative](#)



Market Fulfillment Chart (Direct)

MARKET	COMPETITION	FULFILLMENT DIFFICULTY LEVEL	GAP & ORGANIC CERTIFICATIONS	GRADE & DIVERSITY	PRICING	PACKAGING
Pop-Up/Farmer's Market	High	Easy	No (GAP), Conditional (ORG)	1 & 2 / High	Dynamic	Retail
B&M/Roadside Market	Medium	Easy	No (GAP), Conditional (ORG)	1 & 2 / High	Dynamic	Retail
CSA	High	Moderate-to-Difficult	No (GAP), Conditional (ORG)	1 / High	Static	Retail
E-Commerce (Online)	Low	Difficult	No (GAP), Conditional (ORG)	1 / High	Dynamic	Retail



Market Fulfillment Chart (Wholesale)

MARKET	COMPETITION	FULFILLMENT DIFFICULTY LEVEL	GAP & ORGANIC CERTIFICATIONS	GRADE & DIVERSITY	PRICING	PACKAGING
Terminal Market	Medium	Hard	Yes (GAP), Conditional (ORG)	1 / Low	Dynamic	Bulk
Food Hubs	Medium	Medium	Yes (GAP), Conditional (ORG)	1 / Low-to-High	Dynamic	Bulk
Institutions	Low	Hard	Yes (GAP), Conditional (ORG)	1 / Low	Dynamic	Bulk
Restaurants	High	Medium	No	1 & 2 / Low-to-High	Dynamic	Bulk



Idealized Case Studies

Very Small-Scale Farming

Small-Scale Farming

Mid-Scale Farming



Very Small-Scale Farm Case Study Locally Yours Farms



Photo Credit: Tenisio Seanima

Direct markets:
60% Pop-up
markets, and
Farmer's
markets.

Wholesale
markets: **40%**
Restaurants.



Photo Credit: Tenisio Seanima



Photo Credit: Tenisio Seanima



Photo Credit: [Woolery Back](#)



Small-Scale Farm Case Study

Wanna B Farm



Photo Credit: [Love Is Love Farm](#)

Direct markets:
70% CSA &
Farmer's
Market

Wholesale
markets: **30%**
Restaurants



Photo Credit: [Local Lands](#)



Photo Credit: [Restaurant Eugene](#)



Photo Credit: [Love Is Love Farm](#)

JOURNEYMAN FARMER
CERTIFICATE PROGRAM

Mid-Scale Farm Case Study

Gittin' There Farms



Photo Credit: [Mayflor Farm](#)

Direct markets:
**100% for first
five years
and 75%**
currently Farmer's
markets and Multi-
farm CSA

Wholesale
markets: **25%**
Terminal
Markets
Distributor



Photo Credit: [Truly Living Well](#)



Photo Credit: [Georgia Grown](#)



Photo Credit: [The Turnip Truck](#)

JOURNEYMAN FARMER
CERTIFICATE PROGRAM

Available resources

- USDA. 2015. **Good Agricultural Practices (GAP) & Good Handling Practices (GHP)**. *Agricultural Marketing Service*. <http://www.ams.usda.gov/services/auditing/gap-ghp>
- USDA. 2015. **Grading services**. *Agricultural Marketing Service*. <http://www.ams.usda.gov/services/grading/request-service>
- USDA. 2015. **Market news**. *Agricultural Marketing Service*. <https://www.marketnews.usda.gov/mnp/fv-home>
- USDA. 2015. **Custom average pricing**. *Agricultural Marketing Service*. <http://cat.marketnews.usda.gov/cat/>
- GCI. 2015. **Agribusiness**. *Georgia Centers of Innovation*. <http://www.georgia.org/business-resources/georgia-centers-of-innovation/center-innovation-agribusiness/>



This material is based upon work that is supported by the National Institute of Food and Agriculture, U.S. Department of Agriculture, under award number 2015-70017-22861.



Beginning Farmer and Rancher Development Program

Developing the Next Generation
of Sustainable Farmers in Georgia Grant





Small Fruit and Vegetable Production



Session 7 Putting It Together – Crop Plans

David Berle
Associate Professor
Horticulture Dept
University of Georgia



Learning Objectives

- Alternative methods of crop scheduling
- Importance of matching crop production with market



Cropping systems...it's complicated

- Environmental concerns
- Lots of alternative growing methods
- Market alternatives
- Many different crops, many more cultivars to choose from

JOURNEYMAN FARMER
CERTIFICATE PROGRAM

Selecting a crop to grow

- First step in crop planning
- Labor availability
- Net return on crop
- Pest susceptibility
- Crop rotation
- Soil fertility
- Personal preference
- Market demand



Photo: David Berle

JOURNEYMAN FARMER
CERTIFICATE PROGRAM

Crop selection depends on market

- Varies with market
 - Restaurants
 - Farmers markets
 - CSA
 - Wholesale
- New and unusual crops are important to restaurants
- Who is the customer- chef, broker, individual
- How much does the customer need each week? month? year?



JOURNEYMAN FARMER
CERTIFICATE PROGRAM

Successive Planting

- Considerations
 - Selling period
 - Annual frost-free days
 - Optimal soil temperature
 - Insect/Disease timing
- Need to know
 - Appropriate planting dates
 - Number of days to harvest
 - Length of harvest from first to last pickings



Photo: David Berle

JOURNEYMAN FARMER
CERTIFICATE PROGRAM

Crop planning approaches

- Plant on set schedule, every so many days or weeks
- "Rule of Thumb" method
- Plant several different varieties on the same day
- Plan first and last sowings, guess the rest
- Use Growing Degree Days data

JOURNEYMAN FARMER
CERTIFICATE PROGRAM

Crop planning- Set schedule method

- Beans and corn: Plant every 2 weeks
- Squash and cucumbers: Plant every 3 weeks
- Carrots: Plant every 4 weeks
- Cantaloupes: 2 or 3 plantings at least a month apart

JOURNEYMAN FARMER
CERTIFICATE PROGRAM

Crop planning- Rule of thumb method

After the first planting of these crops...

- Plant next planting of sweet corn when previous crop 1"-2" tall
- Plant next crop lettuce when previous sowing germinates
- Plant next crop beans when young plants start to straighten up



Photo credit: Rheil Gable, Louisiana State University



Crop planning- Different varieties method

- Plant at least 3 different varieties at same time
 - Different days until harvest (maturity)
- Works well for:
 - Corn, tomatoes, cantaloupe, cucumbers
- Example: Cucumber
 - 'Corinto' 48 days
 - 'General Lee' 52 days
 - 'Marketmore' 58 days



Photo: Johannah Bang, UGA/ken



Crop planning- last/first date method

- Determine first possible planting date for your area
 - Soil and air temperature
 - Last average frost date
- Determine last possible planting date
 - Based on first average frost in fall



Ex: First/Last planting date method

- Crop is cucumber
- Avg. first frost in Athens, GA is ~ **Nov. 7** (<http://www.griffin.uga.edu/aemn/>)

# of days from seeding to harvest	60
Avg. length of harvest	21
Days for slow growth in fall	14
Days in case of early frost (if no row cover)	14
Total days before the first frost	109

- Last date for sowing is ~July 18
- Could be later (August 18) if transplants are used



Crop Planning- Growing Degree Days

- Measure of heat accumulation
- Accumulated GDDs can be used to plan dates for succession
- GDDs reflect actual (current or historical) conditions
- A base temperature of 50° F or 55° F is used
- Each day temperature above base temperature, GDD accumulate.



Crop Planning- Growing Degree Days

- Steps to calculate GDD
 - Average max and min temp for 24-hour period
 - Subtract the base temperature for the crop selected
 - Add each day's figure to the total for the year to date
 - This is the GDD figure
- Base temperatures vary with crop
 - Typically 55 °F or 60 °F



Photo: <http://weather.uga.edu/>



Seeding Rates

- Desired yield
- Area of production
- Arrangement in row/bed
- Percent germination
- Specific varieties
- Size of harvested crop
- Growing season of crop
- Disease/insect considerations



Crop scheduling- Organizing plans

Crop	Seeded in flat (planned)	Seeded in flat (actual)	Planted in field (planned)	Planted in field (actual)	Est. days to harvest	Actual days to harvest	Length of harvest	Interval between plantings	Season
Beans, bush					60		2 weeks		Summer
Sweet corn					70-100		2 weeks		Summer
Peppers					60-70		Continuous		Summer
Squash, summer					45-60		4-6 weeks		Summer



Learning Activity - Develop planting schedule

Using the information you brought in from your homework assignment, discuss your basic crop plan.
How did the information in this presentation change your original ideas?



Additional Resources

- Vegetable Garden Calendar (C 943) Georgia Cooperative Extension
(<http://extension.uga.edu/publications/detail.cfm?number=C943>)
- Southeastern Vegetable Crop Handbook
(https://pubs.ext.vt.edu/AREC/AREC-66/AREC-66_pdf.pdf)
- Fall Planting Guide, VA Co-operative Ext Service
(<http://pubs.ext.vt.edu/426/426-334/426-334.html>)
- Weather Information and Calculators
(<http://www.georgiaweather.net/>)
- Maine crop planning software (free)
(<https://code.google.com/p/cropplanning/>)
- Crop Rotation on Organic Farms – A Planning Manual
(<http://www.sare.org/Learning-Center/Books>)





This material is based upon work that is supported by the National Institute of Food and Agriculture, U.S. Department of Agriculture, under award number 2015-70017-22861.



**USDA Beginning Farmer and Rancher
Development Program**
Developing the Next Generation
of Sustainable Farmers in Georgia Grant



Session 7: Resource Page

Marketing

Good Agricultural Practices (GAP) & Good Handling Practices (GHP)

<http://www.ams.usda.gov/services/auditing/gap-ghp>

Agricultural Marketing Service USDA 2015

Grading Services

<http://www.ams.usda.gov/services/grading/request-service>

Agricultural Marketing Service USDA 2015

Market news

<https://www.marketnews.usda.gov/mnp/fv-home>

Agricultural Marketing Service USDA 2015

Custom Average Pricing

<http://cat.marketnews.usda.gov/cat/>

Agricultural Marketing Service USDA 2015

Agribusiness

<http://www.georgia.org/business-resources/georgia-centers-of-innovation/center-innovation-agribusiness/>

Georgia Centers of Innovation (GCI) 2015

Crop Plans

Vegetable Garden Calendar

<http://extension.uga.edu/publications/detail.cfm?number=C943>

Georgia Cooperative Extension C 943

Southeastern Vegetable Crop Handbook

https://pubs.ext.vt.edu/AREC/AREC-66/AREC-66_pdf.pdf

Fall Planting Guide

<http://pubs.ext.vt.edu/426/426-334/426-334.html>

VA Co-operative Ext Service

Weather Information and Calculators

<http://www.georgiaweather.net/>

Maine crop planning software

<https://code.google.com/p/cropplanning/>

Crop Rotation on Organic Farms – A Planning Manual

<http://www.sare.org/Learning-Center/Books>

NOTES: